

B&F

STORNOPHONE 6000
CQM633x
TECHNICAL
MANUAL

Service Coordination.

Date: 04.86.

Edition: 1

Publication no: 8311.6330-00

**CQM633x
TECHNICAL
MANUAL**

TECHNICAL SPECIFICATIONS

1

ADJUSTMENT:

**PROCEDURE
ADJUSTABLE COMPONENTS
TEST POINTS**

2

SERVICE MODE

3

FUNCTIONAL DESCRIPTION:

**BLOCK DIAGRAMS
INTERCONNECTION DIAGRAMS**

4

RADIO FREQUENCY BOARD: RF633x

**DESCRIPTION
ELECTRICAL DIAGRAMS
COMPONENT LAYOUTS
PARTS LISTS**

5

COMMON FUNCTION BOARD: CF6001

**DESCRIPTION
ELECTRICAL DIAGRAMS
COMPONENT LAYOUTS
PARTS LISTS**

6

CONTROL BOX CONTROL LOGIC BOARD: CL6003

**DESCRIPTION
ELECTRICAL DIAGRAMS
COMPONENT LAYOUTS
PARTS LISTS**

7

CONTROL HANDSET AMPLIFIERS: AA6001/AA6002

**DESCRIPTION
ELECTRICAL DIAGRAMS
COMPONENT LAYOUTS
PARTS LISTS**

8

ACCESSORIES

9

**ADDITIONAL MANUAL:
OPERATION AND INSTALLATION**

10

TECHNICAL SPECIFICATIONS

CQM6xxx

GENERAL

TYPE CQM		6332	6333	6334	6112	6113	6114	6774	6662	6663	6664
Freq. & Splits	MHz	66-88 <i>820 Km</i>			136-174 <i>38MHz</i> <i>1520 Km</i>			174-210 190-225	403-470 <i>62MHz</i> <i>2580 Km</i>		
Channel Spacing	kHz	25	20	12.5	25	20	12.5	12.5	25	20	12.5
Channel raster	kHz	6.25	5	6.25	6.25	5	6.25	6.25	12.5	10	6.25
No. of Channels		Up to 99 with CL6003									
Mode		Simplex or semi duplex									
Channel scan	ms	5 for one channel, 10 for 1 MHz									
Frequency Stability (Extreme)		±1.35		±1	±2		±1.5		±2.5		±1.5
Temperature range	deg. C	-25 to +60									
Antenna impedance	Ohm	50									
Speaker	Ohm	4 to 8, balanced (DC power at LS lines)									
Supply	V	13.2 V nominal, 10.8 to 15.6 V at extreme conditions									
Cur. dr.		Including CF (300 mA) and CL (220 mA)									
Off		27		:	17						
RX (stby)	mA	720		:	720						
TX (25 W)		6520		:	7020						
Dim.	mm	D = 175		W = 181		H = 51					
Weight	kg	2.2 incl. Control head (.25) and Cassette (.4)									

RECEIVER

TYPE/CQM		6332	6333	6334	6112	6113	6114	6774	6662	6663	6664
Sensitivity	μ V EMF	0.7		1.0	0.7		1.0	1.15	0.8		1.15
20 dB p-SINAD	dBm	-116		-113	-116		-113	-112	-115		-112
RF Bandwidth	MHz	Varactor tuned to cover total band or band split									
AF output power	W	10 EIA, 8 CEPT method									
Distorsion	%	4 (measured at 4 W)									
Audio freq. bandwith	Hz	300- 3000	300- 3000	300- 2550	300- 3000	300- 3000	300- 2550	300- 2550	300- 3000	300- 3000	300- 2550
Audio freq. response		-6 dB/oct. phase modulation characteristics									
Tolerance	dB	+1 -3	+1 ⁺ -3	+1 -3	+1 ⁺ -3	+1 -3	+1 -3	+1 -3	+1 ⁺ -3	+1 -3	+1 -3
Hum & noise	dB	-45 (EIA, unweighted)									
Radiated spurious	nW	2 (-57 dBm to resonant substition dipole)									
Conducted spurious	dBm	-57									
RX attack time	ms	25 (EIA)									
Recovery time	ms	35									
Adjacent channel selectivity	dB	CEPT 70 2 μ V	FTZ 70 rel.	CEPT 60 2 μ V	CEPT 70 2 μ V	FTZ 70 rel.	CEPT 60 2 μ V	CEPT 60 2 μ V	CEPT 70 2 μ V	FTZ 70 rel.	CEPT 60 2 μ V
Imp. noise selectivity		Ref. 19A701375 paragraph 35									
Blocking	dB μ V	100 (CEPT method)									
Intermodulation	dB	CEPT 76 1 μ V	FTZ 66 +80 2 μ V	CEPT 70 1 μ V	CEPT 76 1 μ V	FTZ 66 +80 2 μ V	CEPT 70 1 μ V	CEPT 70 1 μ V	CEPT 76 1 μ V	FTZ 66 +80 3 μ V	CEPT 70 1 μ V
Spurious rejection	dB μ V	76 (CEPT method)									
CO-channel rejection	dB	8									
Sq. sensitivity	dB	10 - 12 dB SINAD (EIA)									
Squelch tail	ms	15 (EIA)									
Group delay	us	Less than 100 measured at RX line									
RX line	mV	Nominal 110, for 60% deviation									
Proc. RX	mV	Nominal 300, deemphasised, squelched.									
⁺ Tolerance of response from 400 to 2700 Hz is +1, -1.5 dB											

TRANSMITTER

TYPE CQM		6332	6333	6334	6112	6113	6114	6774	6662	6663	6664
RF output power	W	6 W \pm 1 dB or 25 W \pm 1 depending on assembly. Both adjustable down 10 dB from nominal "Softkeying" with 6 ms rise and fall times. Software controlled -10 dB power reduction.									
Duty cycle	%	20% at 60 deg. C (1 min TX/4 min. RX)									
RF bandwidth	MHz	Covers total band or band split.									
Modulation response	Hz	300- 3000	300- 3000	300- 2550	300- 3000	300- 3000	300- 2550	300- 2550	300- 3000	300- 3000	300- 2550
Mod. resp. Nic. input		+6 dB/oct. phase modulation characteristics at 6000 Hz att. \cdot >6 dB rel. to 1 kHz value.									
Tolerance	dB	+1 -3	+1* -3	+1 -3	+1* 3	+1 -3	+1 -3	+1* -3	+1 -3	+1 -3	+1 -3
Maximum deviation	kHz	5	4	2.5	5	4	2.5	2.5	5	4	2.5
Conducted	dBm	-37									
Radiation spurious	nW	200 (-37 dBm to resonant substitution dipole)									
Audio distortion	SPL	94 dB rel. 2×10^{-5} Pascal for 60% -90% of rated deviation corresponding to 110 mV \pm 3 dB									
Audio distortion	%	5 (CEPT)									
Resident modulation	dB	-40 (Weighted, CEPT), -37 (unweighted, DOC)									
Adjacent Channel power	dB/ C	-70	N/A	-60	-70	-60	-70	-60	-70	-60	-60
Attack time	ms	15									
Decay time	ms	5									
Group delay	us	Less than 100 measured at TX line									
TX stability		4.5:1 VSWR, all phase angles									
TX line		10 Hz to 3000 Hz, 1.0 V RMS for 60 % dev.									
* Tolerance of response from 400 to 2700 Hz is +1, -1.5 dB.											

ADJUSTMENT PROCEDURE

CQM6330

INSTRUMENTS

The following instruments are necessary in order to perform a complete adjustment of a Stornophone 6000 radiotelephone.

AF Voltmeter	$Z_i \geq 1$ Mohm
DC Voltmeter	$R_i \geq 1$ Mohm
DC Amperemeter	0 - 1/0 - 10 A
RF Generator	10 - 470 MHz
RF Wattmeter	68 - 470 MHz
Deviationmeter	68 - 470 MHz
Frequency counter	0.4 - 512 MHz
Distortionmeter	Psophometric
AF Generator	0.1 - 10 kHz
DC Power Supply	10 - 20 V/0-10 A
RF Probe	Part no. 95.0059-00
Trimming Tool	Part no. 17.0053-00
6000 Service Box	Part no. 95D5014-00
Service Prom M6000	Part no. 95D5015-00

GENERAL NOTES

During test and adjustment DC power (13.2 V) must be connected and the radio turned on.

The personality prom U904 must be replaced by a test prom.

VOLTAGE REGULATOR

Connect the DC power supply to the radio and set the voltage to 13.2 V

Turn the radio on.

Read the current drain.

Requirement: $I > 250$ mA

Connect a DC voltmeter to R716.

Adjust R709 for $5 \text{ V} \pm 0.1 \text{ V}$.

WARNING

Never set the +5 V supply to be higher than +6 V, even for a short period, as overvoltage can destroy the circuitry.

Connect a voltmeter to P102 pin 2.

Adjust R719 for $-24 \text{ V} \pm 0.1 \text{ V}$.

Note: Readjustment of R719 requires readjustment of the receiver.

TRANSMITTER ADJUSTMENT

During adjustment the transmitter must be connected to an RF wattmeter and keyed.

Connect a voltmeter to P102 pin 9. (LOCK)

Check that the lock signal is 0 V (Low).

Adjust R133 for rated RF power.

Select a channel with reduced power, if used.

Adjust R132 for rated reduced power.

TRANSMITTER FREQUENCY

Connect a frequency counter to the antenna output through a suitable attenuator.

Adjust L701 for nominal transmitter frequency.

Requirement: $F_{\text{nom}} \pm 0.2$ p.p.m. (parts per million)

TRANSMITTER MODULATION

Connect an AF generator to P102 pin 3- (4= GND).
Connect a deviation meter to the antenna output through a suitable attenuator.

Set the generator frequency to 1 kHz and the output to 1.66 V r. m. s.

Set R 677 to its center position.

Select the center channel in the high frequency window: 86.970 MHz

Adjust R675 for maximum deviation:

CQM6xx2: ± 5 kHz +0/-100 Hz

CQM6xx3: ± 4 kHz +0/-100 Hz

CQM6xx3: ± 2.5 kHz +0/-100 Hz

Select the center channel in the low frequency window: 66.46 MHz

Adjust R680 for maximum deviation:

CQM6xx2: ± 5 kHz +0/-100 Hz

CQM6xx3: ± 4 kHz +0/-100 Hz

CQM6xx4: ± 2.5 kHz +0/-100 Hz

Select the center channel in the middle frequency window: 74.040 MHz

Set the AF generator output to 1.66 V r. m. s.

Alternately set the generator frequency to 1 kHz and 20 Hz.

Adjust R677 for the same deviation at both modulation frequencies (± 100 Hz).

Check and if necessary readjust R677 for maximum deviation (+0/-100Hz).

Connect the AF generator to J901 pin 22 (TX LINE).

Adjust the generator output to obtain 60% of maximum deviation:

Requirement: AF input 100 mV ± 3 dB.

RECEIVER ADJUSTMENT

RECEIVER FRONT END

Select the center channel of the low RX frequency window: 66.510 MHz

Connect a diode probe and DC-Voltmeter to TP7.

Connect a signal generator to the antenna input and set its frequency to the channel frequency.

Set the generator to 0 dB (225 mV - $\frac{1}{2}$ e. m. f.).

Adjust L301, L302 and L304 for maximum voltmeter reading.

Adjust L306 for maximum reading, L308 for maximum reading and L310 for minimum reading.

Repeat the adjustments until no further improvements in minimums and maximums are possible.

Connect the diode probe and voltmeter to TP3.

Adjust L313 and L314 for maximum voltmeter reading.

Select the center channel of the high RX frequency window: 87.060 MHz

Set the signal generator frequency to the channel frequency.

Connect a distortion meter to P102 pin 10 (RX LINE).

Adjust R663 for best sensitivity (SINAD).

The radio can now cover the entire frequency band without readjustment.

ALTERNATIVE METHOD

If the RX window is less than 10 MHz:

Connect a voltmeter to TP12.

Adjust R633 for a voltage reading according to the graph (± 50 mV).

Connect a diode probe and voltmeter to TP3.

Adjust L313 and L314 for maximum reading.

Connect a RF signal generator to the antenna input.

Set the generator frequency to the center channel frequency and the modulation frequency to 1 kHz and 60% deviation.

Adjust the following coils for best sensitivity (SINAD).

L301, L302, L304, L306, L308, L310, L312.

21.4 MHz IF AMPLIFIER

Connect a signal generator to the antenna input. Set the generator frequency to the channel frequency.

Set the generator output to 15 mV (10 - 20 mV) unmodulated.

Connect a diode probe to TP5.

Adjust L403 and L405 for maximum.

Set the generator output to 1 mV unmodulated.

Connect a frequency counter to TP6.

Connect a distortionmeter and an oscilloscope to P102 pin 10 (RX LINE).

Adjust L408 for 455 kHz.

Alternative: Adjust L408 for minimum distortion with 100% modulation. The decrease in distortion is small (approx. 1%).

Set the generator modulation to 1 kHz and 60% deviation.

Adjust L406 and L409 for minimum distortion.

Adjust L410 for best demodulated/recovered audio signal on the oscilloscope.

Adjust R426 for 110 mV (RX LINE).

RECEIVER SENSITIVITY.

Measure the 20 dB psophometric SINAD on all channels.

Typical sensitivity:

CQM6332: 0.7 μ V

CQM6333: 0.7 μ V

CQM6334: 1.0 μ V

SQUELCH

Connect a signal generator to the antenna input. Set the generator frequency to the channel frequency. Set the modulation to 1 kHz and 60% deviation.

Connect a distortion meter to J102 pin 10.

Connect a voltmeter to P102 pin 11.

Adjust the generator output to obtain 10 - 12 dB SINAD.

Adjust R442 so that the squelch just opens.

Squelch open: ≤ 1 V

Squelch closed: ≥ 3 V

CURRENT CONSUMPTION

Measure the current consumption in off state, receive and transmit mode:

OFF: 27 mA

Receive Stand-by: <750 mA

Transmit (25 W): 6.52 A

Values are typical and may only be used for reference.

TEST PROM

CQM6xxx

Part no. 95D5015-00

CHANNEL	RADIO	RX-FREQUENCY	TX-FREQUENCY	POWER
11	611x	136.900	136.900	Full
12	611x	151.150	150.400	Full
13	611x	172.450	172.300	Full
14	611x	155.000	155.000	Redu.
31	633x	66.510	66.460	Full
32	633x	74.520	74.040	Full
33	633x	87.060	86.970	Full
34	633x	77.000	77.000	Redu.
61	666x	404.600	404.700	Full
62	666x	430.200	430.700	Full
63	666x	467.300	467.400	Full
64	666x	436.500	436.500	Redu.
71	677xL	174.900	174.900	Full
72	677xL	188.900	188.400	Full
73	677xL	208.600	208.600	Full
74	677xL	192.000	192.000	Redu.
75	677xH	190.900	190.900	Full
76	677xH	204.560	204.300	Full
77	677xH	223.650	223.600	Full
78	677xH	207.500	207.500	Redu.
TON ZVEI I Enc () (1A, 2A, 3A, 4A, 5A) SNC (S) (1,) DUR 2.5 sec. DEC (1, 2, 3, 4, 5) ACK = DEC QUEUE for 5 sec. + "2718" = Servicemode. "730" = Write in EE PROM "720" = Read in EE PROM				

ADJUSTMENT PROCEDURE

STORNOPHONE 6000

The following instruments are required for adjustment and measuring performance data of a STORNOPHONE 6000 radiotelephone.

RF Signal generator	10-470 MHz
Deviation meter	10-470 MHz
RF Watt meter	10-470 MHz/0-30 W
RF attenuator	10-470 MHz/20 dB/40 dB
Distortion meter	SINAD/Psophometric
Frequency counter	0.1-470 MHz
AF Generator	10 Hz-10 kHz

The above mentioned instruments can be replaced with a radiotelephone test set e. g.

Stabilock/Slumberger 4040

DC Power supply	0-20 V/0-10 A
Oscilloscope	DC-15 MHz
AC voltmeter	Zi= 1 Mohm/1 mV
DC voltmeter	Ri= 20 Kohm/V
DC voltmeter	Ri= 1 Mohm

TRIMMING TOOLS

Trimming tool	17. 0053-00
RF probe	95. 0059-00

ADJUSTMENT PROCEDURE

The adjustment procedure is divided into four section:

- Transmitter RF circuits
- Transmitter Modulation circuits
- Receiver RF circuits
- Receiver AF circuits

Before the alignment or adjustment of any circuits the radiotelephone should be connected to a test setup as shown on D404. 344 (Transmitter) or D404. 345 (Receiver).

VOLTAGE REGULATOR

Connect the radiotelephone to a DC power supply and set the voltage to 13.2 volt.

Turn the radio on.

Check the current drain, approx. 0.25 A.

Connect a voltmeter to TP13.

Read the voltage, 8.5 V.

Connect a voltmeter to P102 pin 2.

Read the voltage, -24 V.

Connect a voltmeter to the rear connector, J901 pin 9.

Read the voltage +5 V.

TRANSMITTER ADJUSTMENT

All transmitter adjustments are performed with the transmitter keyed unless otherwise noted.

Connect the antenna output to a wattmeter.

Adjust R133 for rated power, 25 W or 10 W.

If the radio has channels with reduced power select a channel programmed with reduced power.

Adjust R132 for rated reduced power.

Connect a frequency counter to the antenna output through a suitable attenuator.

Adjust L701 for nominal transmitter frequency.

CQM666x only

Adjust L1 in U611 oscillator for nominal transmitter frequency.

Frequency adjustment accuracy:

$F_{nom} \pm 0.2$ p. p. m. (parts per million)

e. g. $F_{nom} = 445.125$ MHz

tolerance = 445.1161 MHz - 455.1339 MHz

TRANSMITTER MODULATION

Connect a deviation meter to the antenna connector through a suitable attenuator.

Connect an AF Generator to J904 pin 4.

Set the generator output to 1 V.

Key transmitter.

Vary AF generator frequency between 100 Hz and 3000 Hz to find the frequency which produce the highest frequency deviation. Check both + and - modulation.

At the AF frequency giving peak deviation adjust R675 for maximum permissible frequency deviation:

CQM6xx2 = ± 5 kHz

CQM6xx3 = ± 4 kHz

CQM6xx4 = ± 2.5 kHz

RECEIVER ADJUSTMENT**RECEIVER SENSITIVITY**

Connect an RF generator to the antenna connector. Set the signal generator to the channel frequency. Set the generator modulation frequency to 1 kHz.

Adjust the frequency deviation to:

CQM6xx2 = ± 3 kHz

CQM6xx3 = ± 2.4 kHz

CQM6xx4 = ± 1.5 kHz

Measure 20 dB psophometric SINAD on all channels:

Typical Sensitivity:

CQM6112 = 0.7 μ V

CQM6113 = 0.7 μ V

CQM6114 = 1.0 μ V

CQM6332 = 0.7 μ V

CQM6333 = 0.7 μ V

CQM6334 = 1.0 μ V

CQM6662 = 0.8 μ V

CQM6663 = 0.8 μ V

CQM6664 = 1.15 μ V

CQM6774 = 1.15 μ V

Values are e. m. f.

AF LINE LEVEL

Connect the RF Generator to the antenna connector. Set the generator frequency to the channel frequency. Set the generator output to 1 mV.

Set the frequency deviation to:

CQM6xx2 = ± 3 kHz

CQM6xx3 = ± 2.4 kHz

CQM6xx4 = ± 1.5 kHz

Connect an AF voltmeter to P102 pin 10.

Adjust R424 for 110 mV ± 5 mV.

RECEIVER SQUELCH ADJUSTMENT

Connect a psophometric distortion meter to the AF output.

Adjust the signal generator output for 10 dB SINAD.

Connect a voltmeter (10 V) to P102 pin 11.

Adjust R442 so that the squelch just opens.

Squelch open = ≤ 1 V

Squelch closed = ≥ 3 V

Vary the RF generator output to find the points of squelch open and squelch closed (Squelch hysteresis).

Typical squelch hysteresis= 1-4 dB

CURRENT CONSUMPTION

Measure the current consumption in off, transmit and receive mode:

	<u>CQM611x/633x</u>	<u>CQM666x/6774</u>
OFF	27 mA	17 mA
RX standby	720 mA	720 mA
TX (25 W)	6520 mA	7020 mA

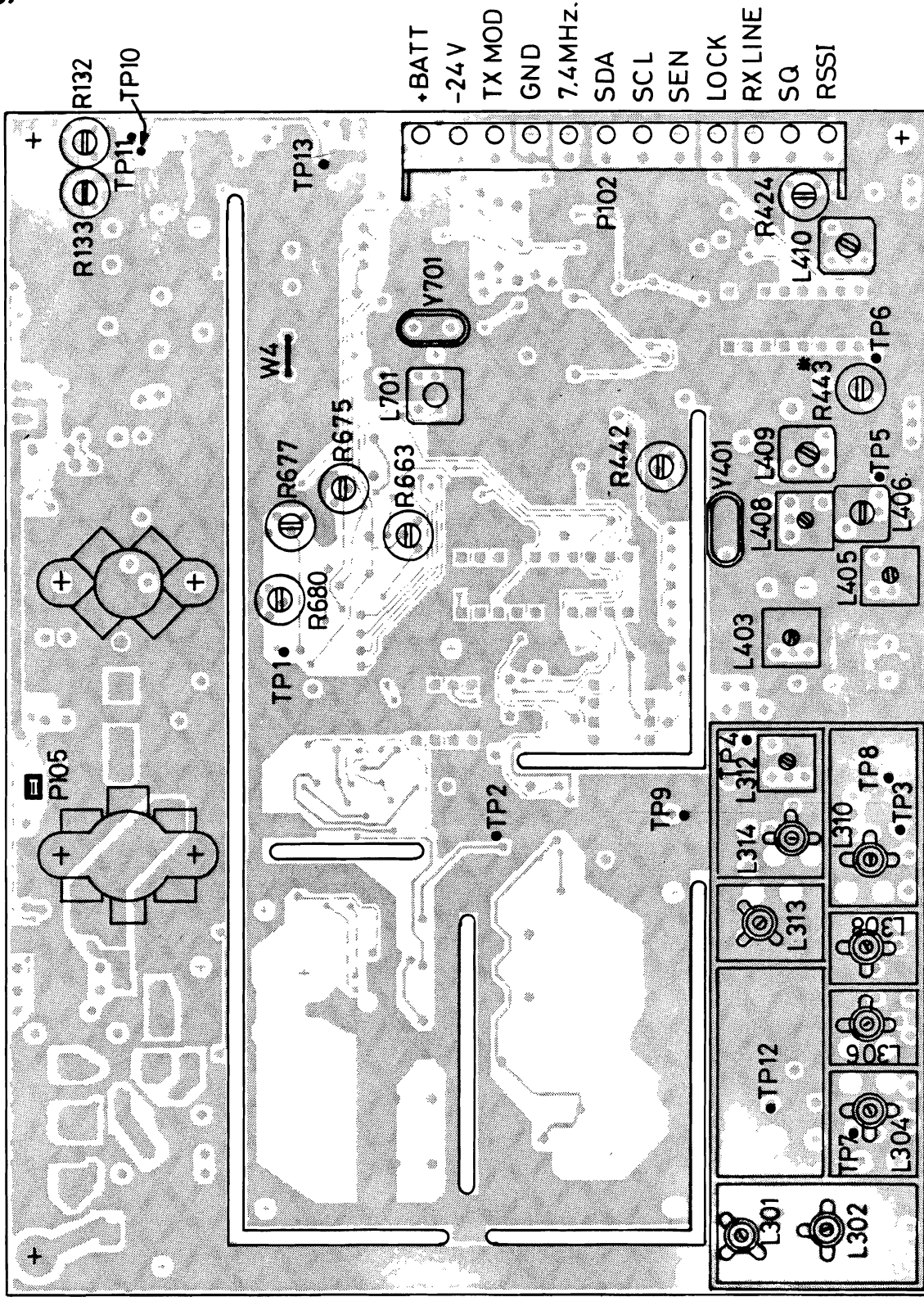

* ONLY FOR RSSI

ADJUSTABLE COPONENTS AND TEST POINTS
RF BOARD 6330L

M405.285

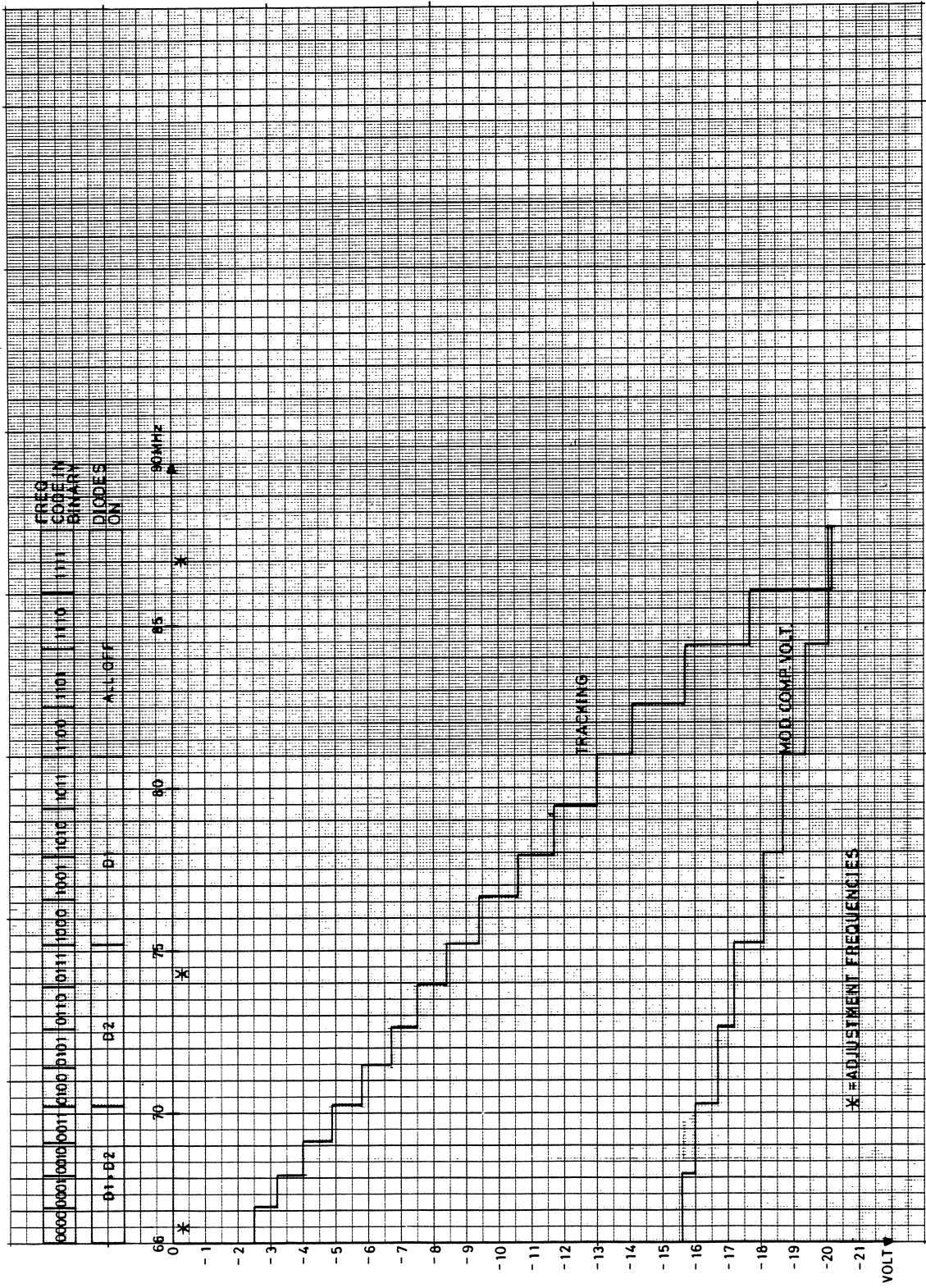

Storno

Storno

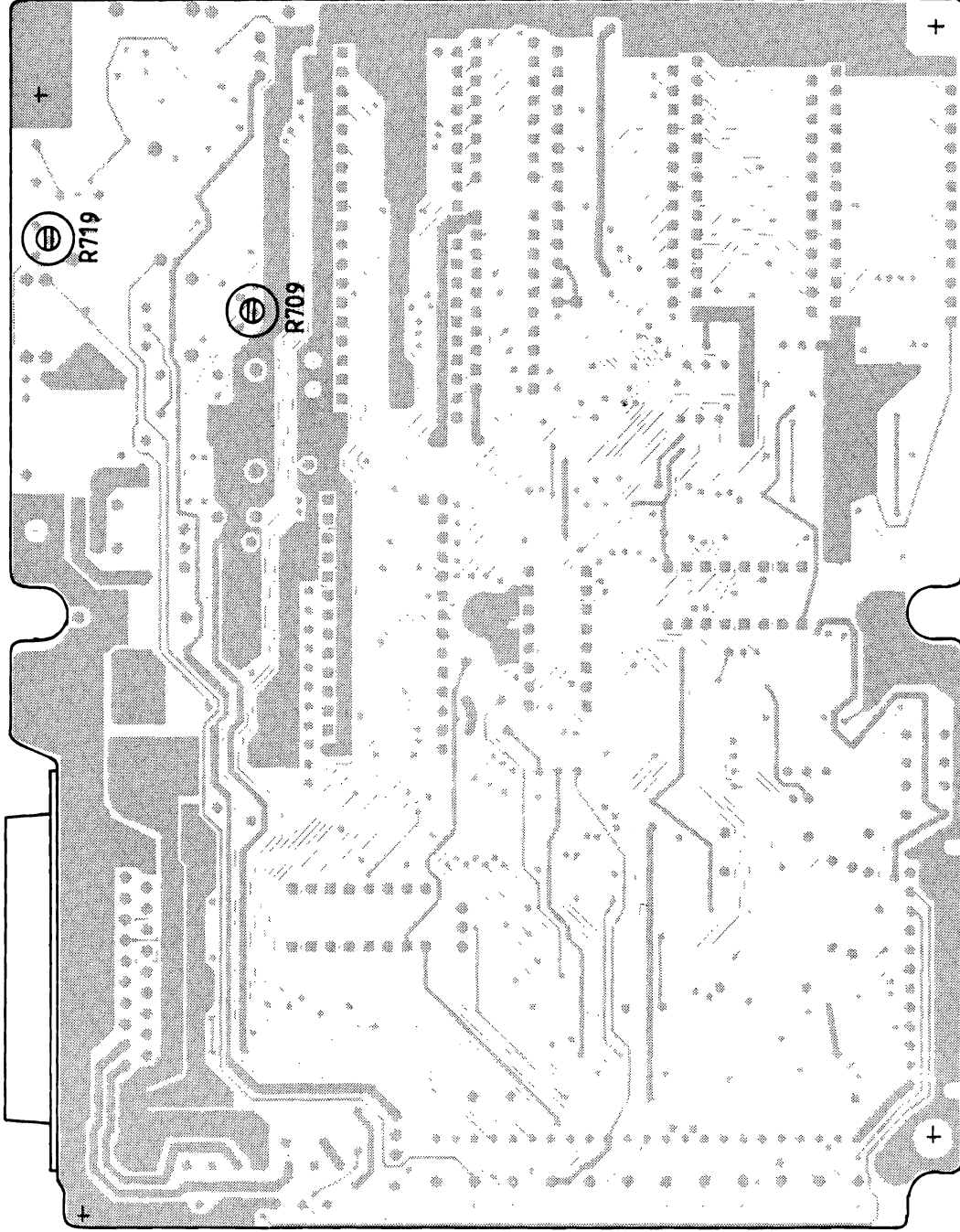

ADJUSTABLE COMPONENTS AND TEST POINTS
COMMON FUNCTION BOARD CF6001

M405. 254

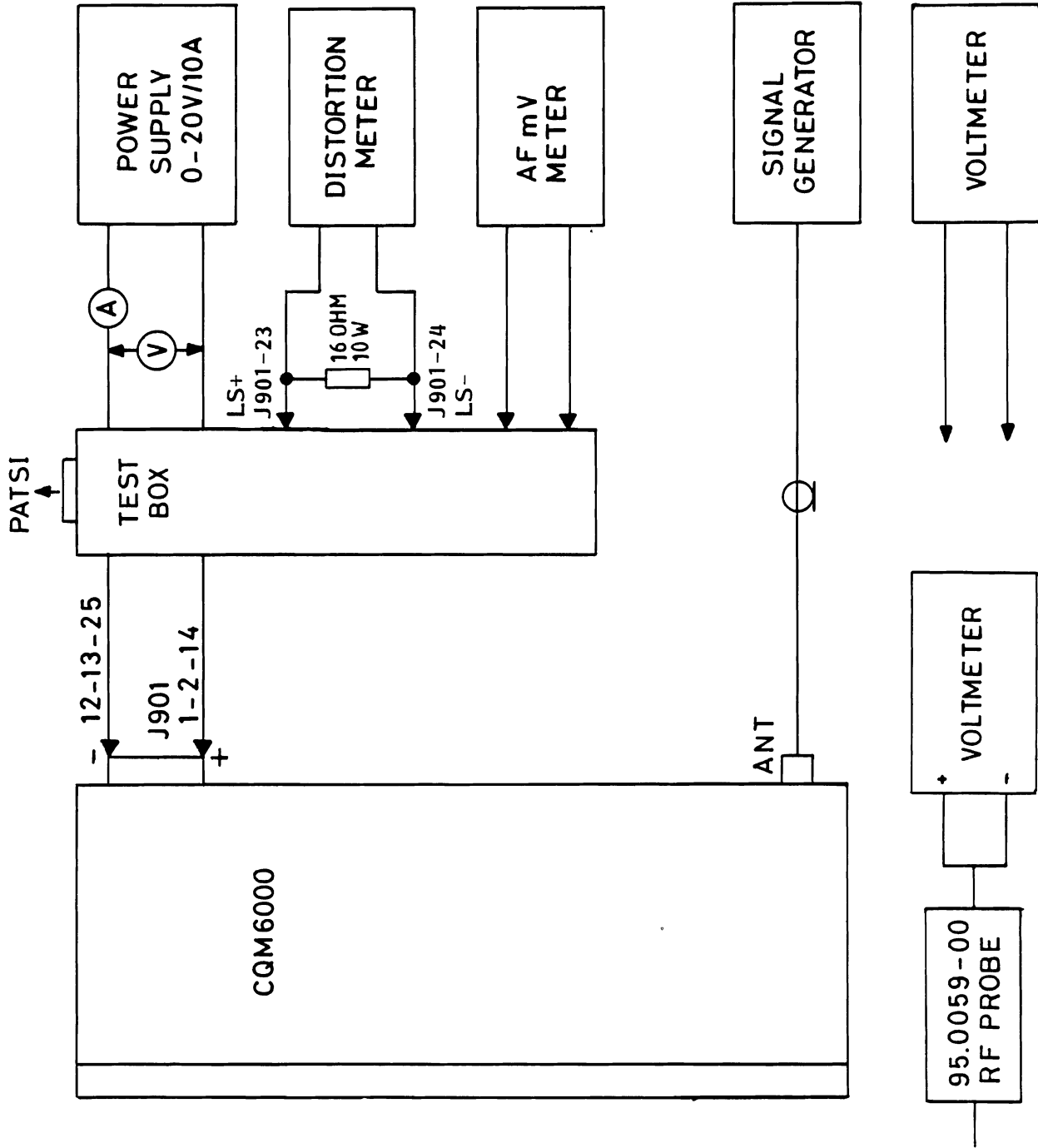

STORNOPHONE 6000
RECEIVER TEST SETUP

D404. 345/2

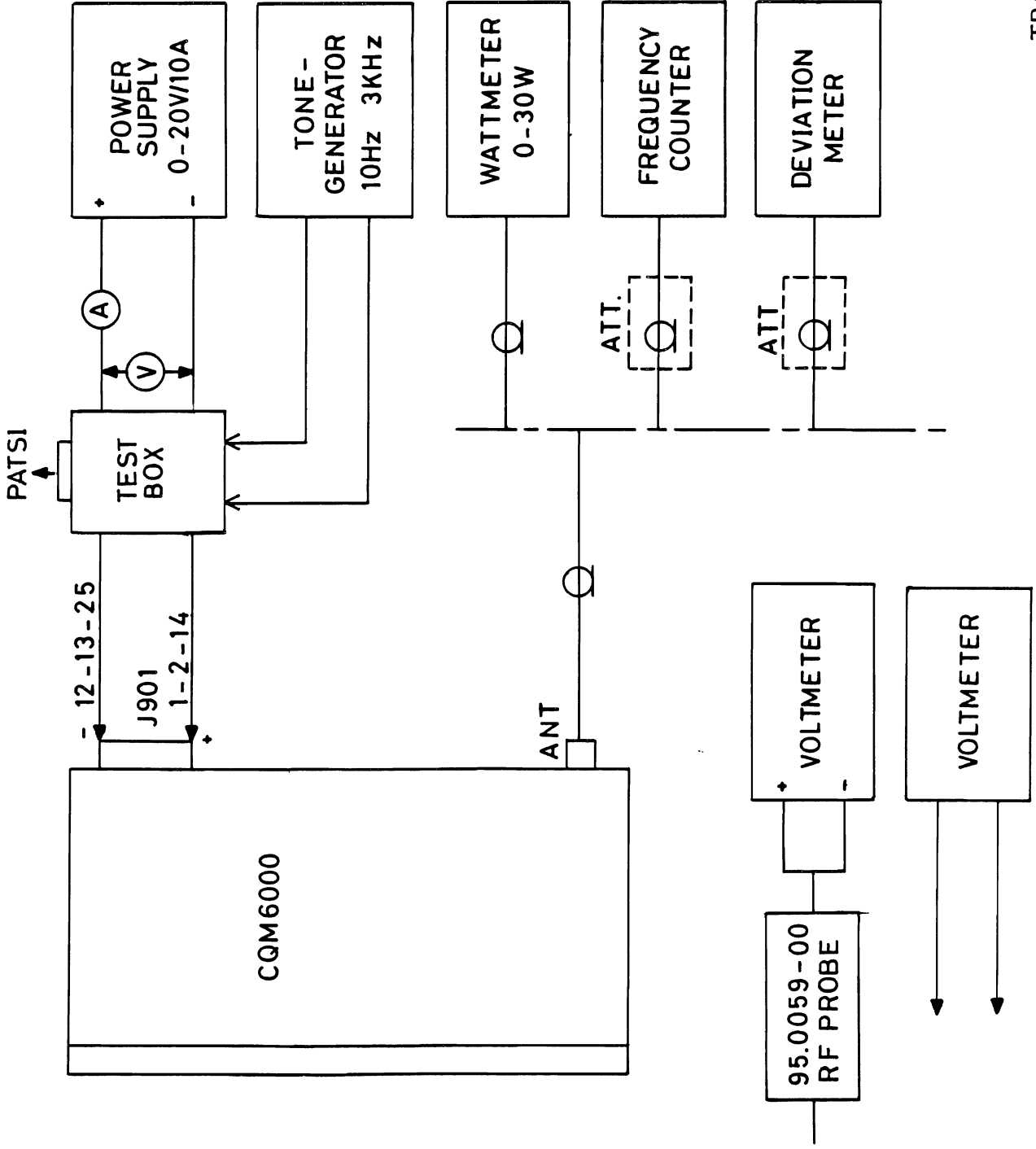

STORNOPHONE 6000
TRANSMITTER TEST SETUP

SERVICE MODE

CQM6xxx

The Stornophone 6000 has an inherent service mode which can be involved with a jumper on the rear connector or by using SE6001 (PATSI).

The service mode has facilities for:

- Channel select
- Volume select
- Tone signalling select
- Memory read/programming of the EE prom if installed.

These functions are called by entering a 3-digit code for the wanted function. Some functions also require that parameters and data are entered.

Channel Select (1xx)

The channel select mode is function group 1 and the syntax is:

- 1 + channel group (0-3)
- 100= clear channel select mode

Volume Select (4xx)

The volume select mode is function group 4 and the syntax is:

- 4 + 1 volume level
- 400= clear volume select mode

Tone Signalling Select (5xx)

The tone signalling select mode is group 5 and the codes are:

<u>Code</u>	<u>Parameter</u>	<u>Description</u>
521	None	Enable decoding
522	System	Select decoder system
523	Digits	Number of digits in decoder
531	None	Send telegram
532	System	Select encoder system
533	Digits	Select number of digits in encoder
534	Telegram	Tone telegram for encoder
500		Clear tone signalling

Programming Mode (7xx)

The programming mode is used to display the contents of the different memory devices in the radio and provided that an EE-Prom is used also to program personality data. However, due to the complexity of the data structure in the personality prom care must be taken not to alter data which may be dependent on other data or pointers in the system. It must also be stressed that data can be overwritten only if they match the available space exactly. It is f.ex. not possible to change the number of tones in the encoder to a new value without upsetting the data flow in the radio.

The syntax of the programming mode is:

Function code + address + (data, data, data - - -)

<u>Code</u>	<u>Parameter(s)</u>	<u>Description</u>
710	Address	Read Program memory Address 00H - BFFFH
720	Address	Read personality prom Address C000 - C7FF
730	Address + data	Write to personality prom
700		Clear programming

Addresses and data are entered in decimal form and corresponding to Hexadecimal as follows:

<u>ENTER</u>	<u>HEX</u>	
0 + 0 (00)	0	<u>Any other key entry is not valid</u>
0 + 1 01	1	<u>and ignored with an error tone</u>
0 + 2 02	2	<u>being emitted</u>
0 + 3 03	3	
0 + 4 04	4	
0 + 5 05	5	
0 + 6 06	6	
0 + 7 07	7	
0 + 8 08	8	
0 + 9 09	9	
1 + 0 10	A	
1 + 1 11	B	
1 + 2 12	C	
1 + 3 13	D	
1 + 4 14	E	
1 + 5 15	F	

Any sequence requiring data entry is terminated by pressing *****.

Example

Display the contents of the personality prom at address: C304

<u>ENTER</u>	<u>DISPLAY</u>
720	720 A =
12	720 A = C
03	720 A = C3
00	720 A = C30
04	720 A = C304 D = 39

Pressing numeric key (1-9) steps the address forward corresponding to the pressed key.

01	720 A = C305 D = C7
04	720 A = C309 D = 35

The 000 Code

At any time when in service mode entering 0-0-0 causes the radio to revert to the initial state of service mode. (CLEAR ALL)

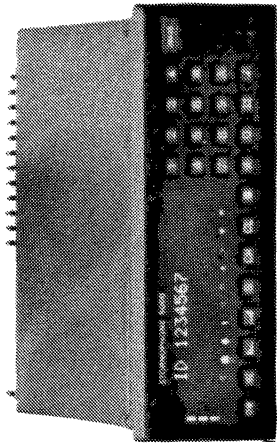

RADIO UNIT WITH ONE CONTROL BOX, LOCAL INSTALLATION.



RADIO UNIT WITH JUNCTION BOX AND TWO CONTROL BOXES AS OPTIONS REMOTE INSTALLATION.

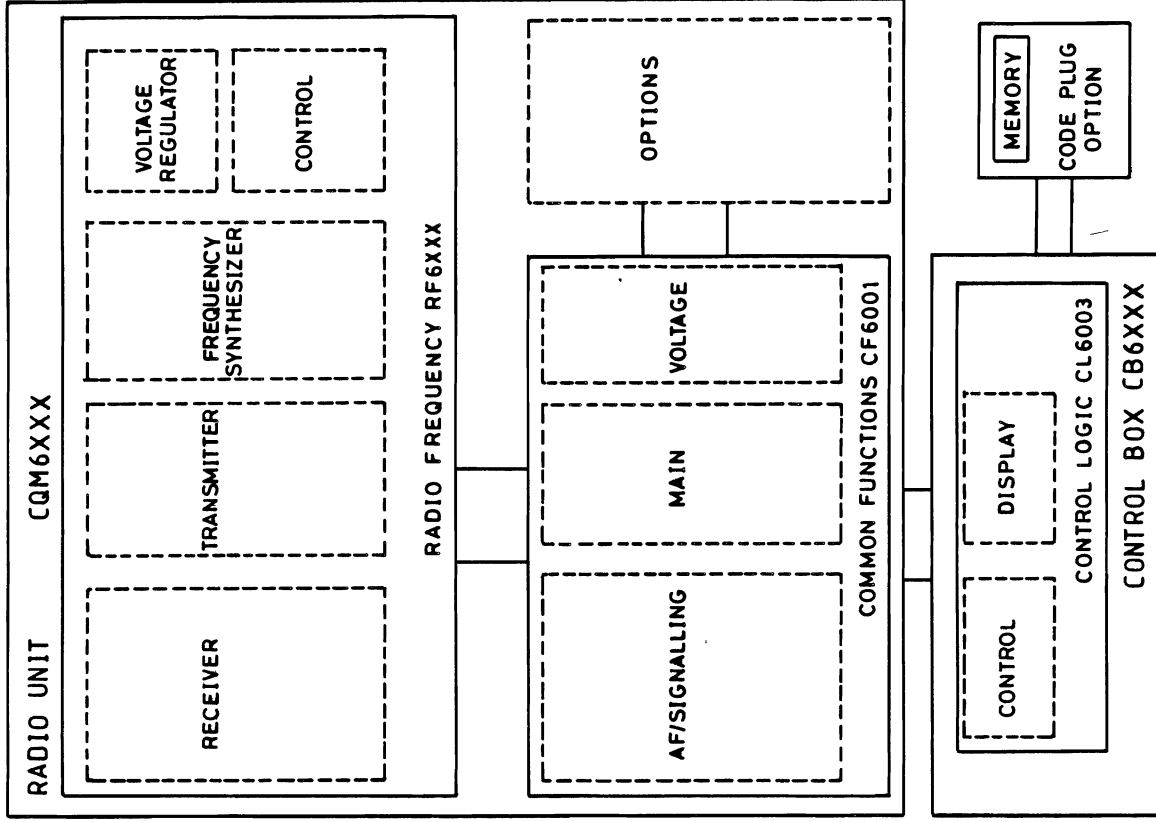
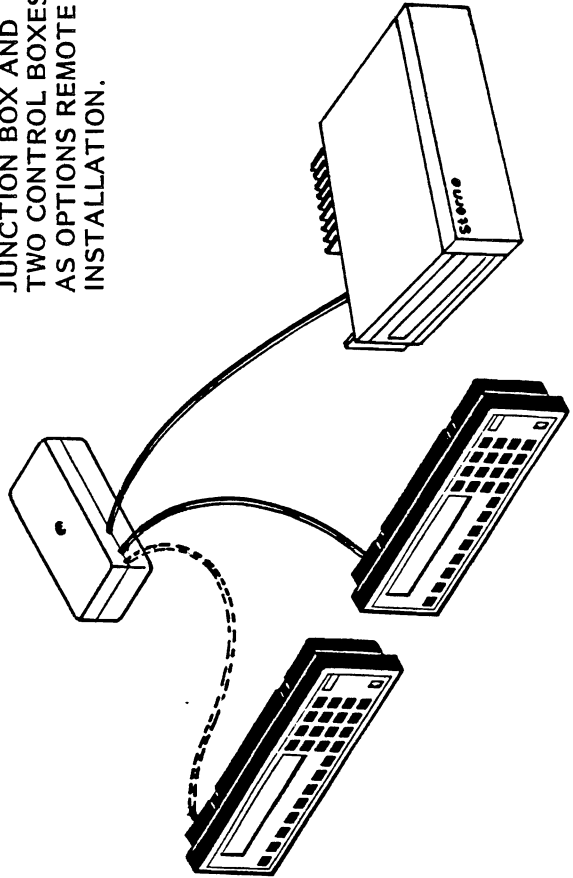

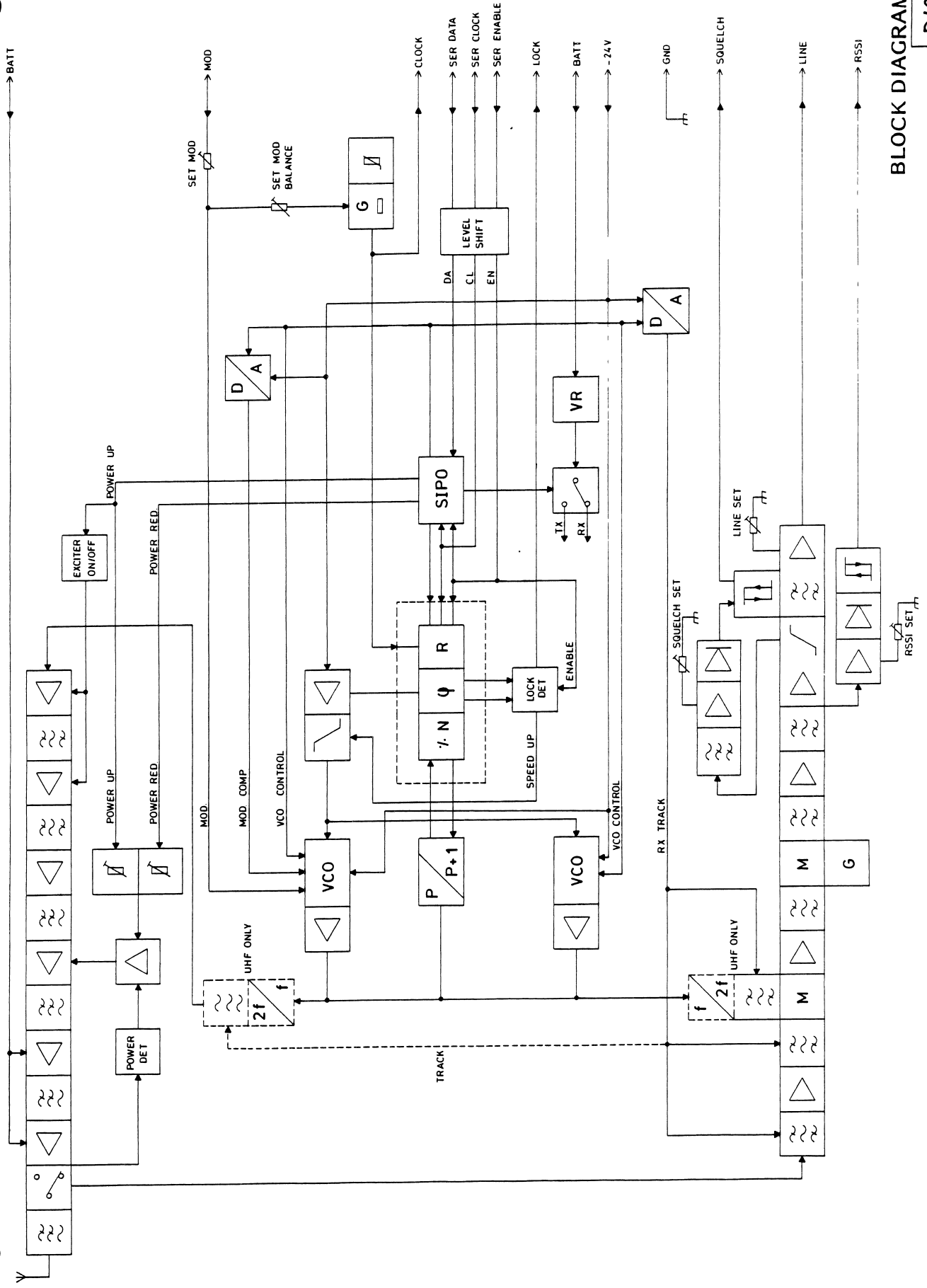

BLOCK DIAGRAM RF6xxx
D404.048/2

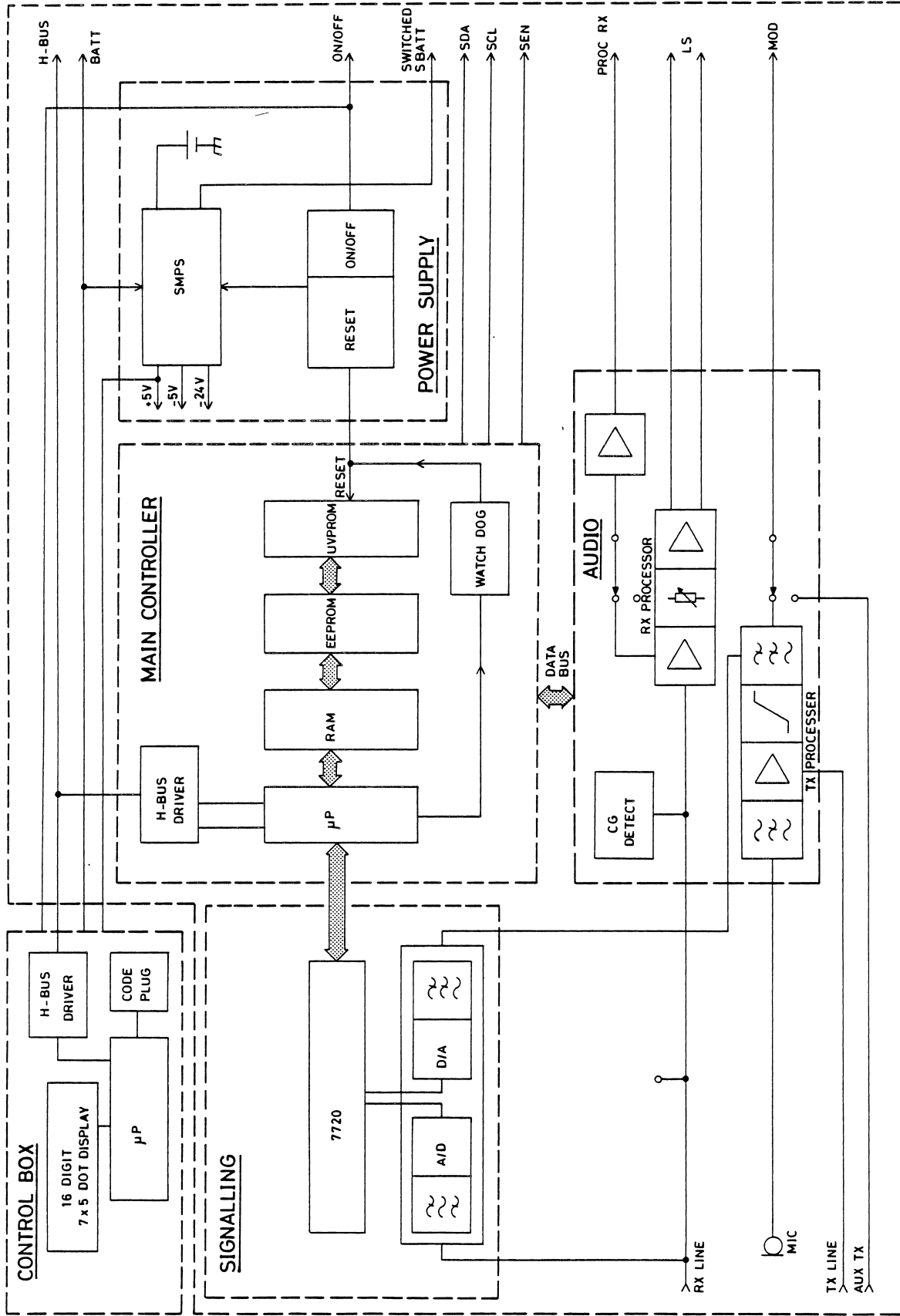

SIGNALING DIAGRAM FOR CF6001 AND CL6003

D404.051/2

OPTIONAL BOARD

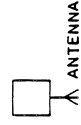
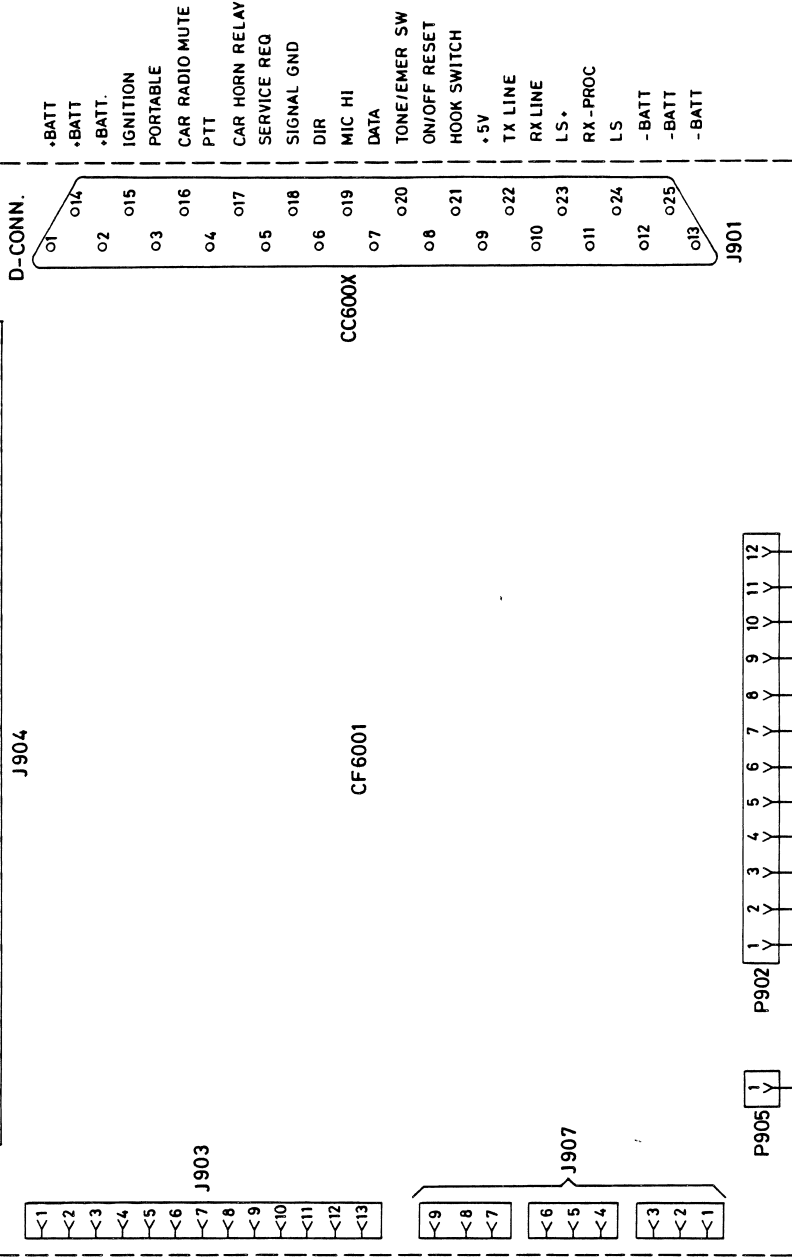
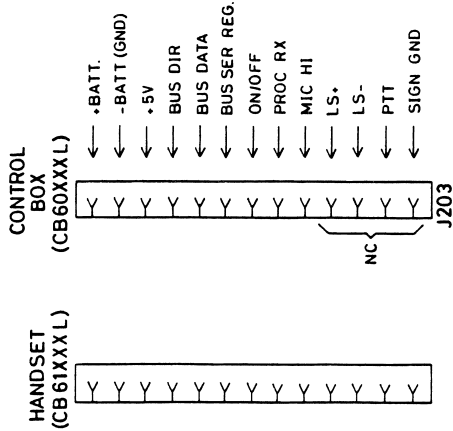
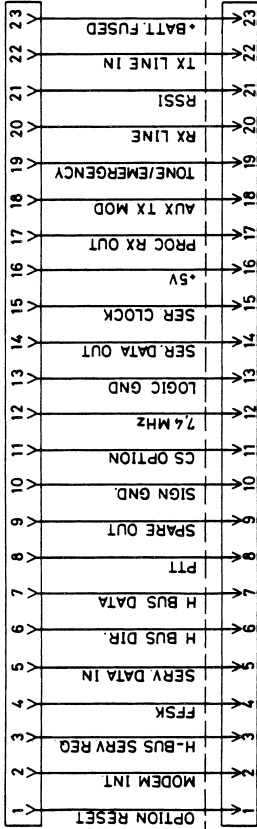

INTERCONNECTION DIAGRAM CQM6000

D404.225/2

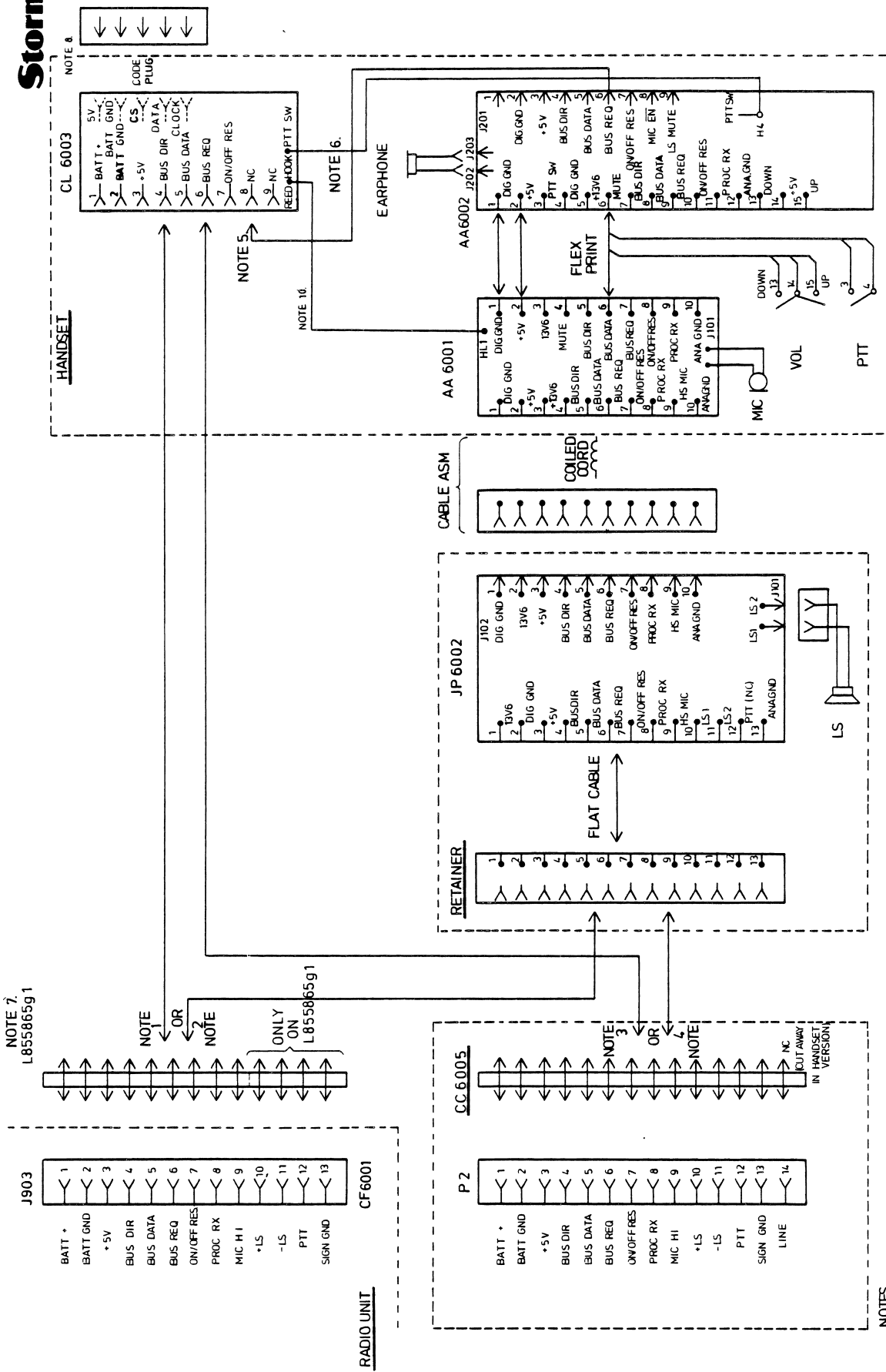

NOTES

- 1 CONTROL PANEL VERSION
- 2 HANDSET VERSION
- 3 REMOTE CONTROL PANEL VERSION.
- 4 REMOTE HANDSET VERSION
- 5 HANDSET VERSION
- 6 SOLDERED TO CL6003 AND AA6002
- 7 19L855865 IS USED IN LOCAL HANDSET VERSION
- 8 CODE PLUG ONLY USED IN CODE PLUG VERSION.

9. THE FOLLOWING NAMES STANDS FOR THE SAME

- BATT + - 13V6
- BATT GND - DIG GND
- LS EN - LS MUTE
- +LS - LS1
- LS - LS2
- SIGN GND - ANA GND
- MIC HI - HS MIC
- 10 WIRE FOR HOOK SWITCH SOLDERED ON CL6003 AND AA6001

>>> THIS DOCUMENT REMAINS STORNO'S PROPERTY AND STORNO RESERVES ALL RIGHTS IN RESPECT TO THIS DOCUMENT. WITHOUT STORNO'S WRITTEN PERMISSION THE CONTENTS OF THE DOCUMENT MUST NOT BE IMPARTED TO A THIRD PARTY NOR BE USED FOR ANY UNAUTHORIZED PURPOSE <<<

RF6xxx

RADIO FREQUENCY BOARD

RECEIVER

RECEIVER FRONT-END

The front-end consist of a 2 resonator input filter, a grounded emitter bipolar transistor RF amplifier Q301, a four resonator intermediate filter, a JFET mixer Q302 and a junction buffer amplifier Q401, which makes a constant load to the mixer and impedance matching to the crystal filter.

The incoming signal from the antenna passes through a low pass filter and the antenna switch before the receiver front-end.

The front-end varactors are tuned by a tracking voltage supplied from U606 and determined by the synthesizer.

The injection signal from the RX VCO is filtered through a 2 resonator varactor tuned filter and mixed with the antenna signal in Q302. The varactors D306/7 are tuned by the tracking voltage. The receiver injection is measured at TP3.

FIRST IF

The first intermediate frequency is 45 MHz.

The first IF passes through a buffer amplifier Q401, a two stage monolithic crystal filter Z401a, b and is fed to a dual gate MOSFET amplifier Q402. The purpose is to overcome the noise figure of the following stages while providing a constant load to the crystal filter with varying signal levels.

SECOND IF AND DEMODULATOR

The output of the oscillator circuit Y401 (45.455 MHz), Q404, L408 and associated components is injected to the second FET mixer Q403.

The mixer is followed by a differential amplifier (Q405-Q406). The selectivity of the 455 kHz amplifier is formed by two ceramic filters (Z402 and 403) located at the input and output of the amplifier. The following IC, U401, works as limiter, quadrature discriminator and line amplifier.

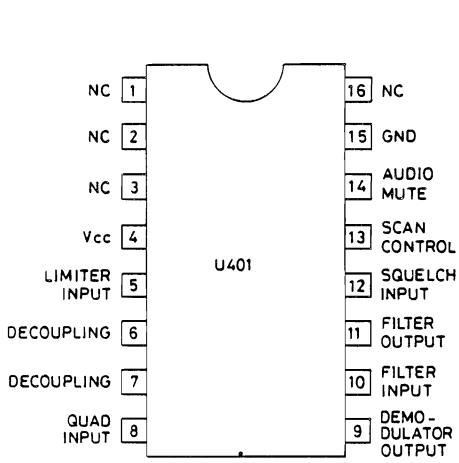

PINNING FOR U401

2nd IF AMPLIFIER D404.391

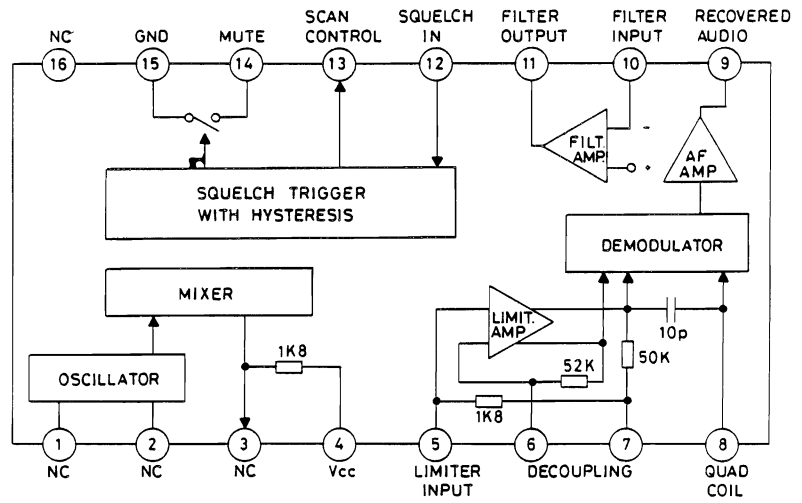

BLOCK DIAGRAM FOR U401

2nd IF AMP. D404.390

SQUELCH

U402 is a squelch unit micromodule. It filters, amplifies and detect the noise of the AF signal

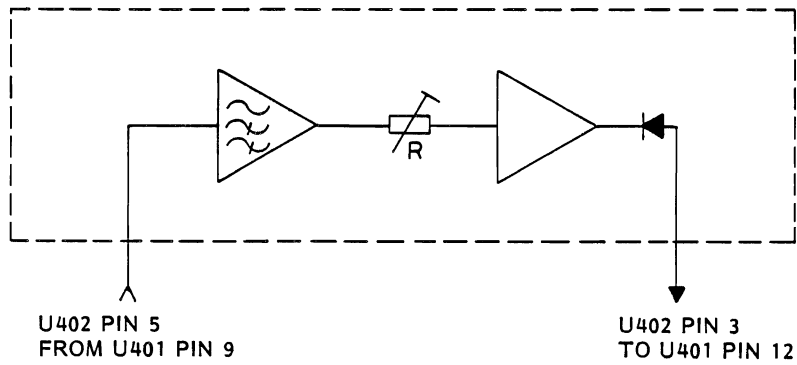

Two amplifiers in a dual low current operational amplifier are used. The signal from U401 pin 9 passes through an active high-pass filter with cut-off at about 4.5 kHz. The second amplifier stage amplifies the selected noise signal and feeds it to the detector in U401 at pin 12. The variable resistor sets the gain. (See electrical drawing later on in this chapter).

SYNTHESIZER CIRCUIT

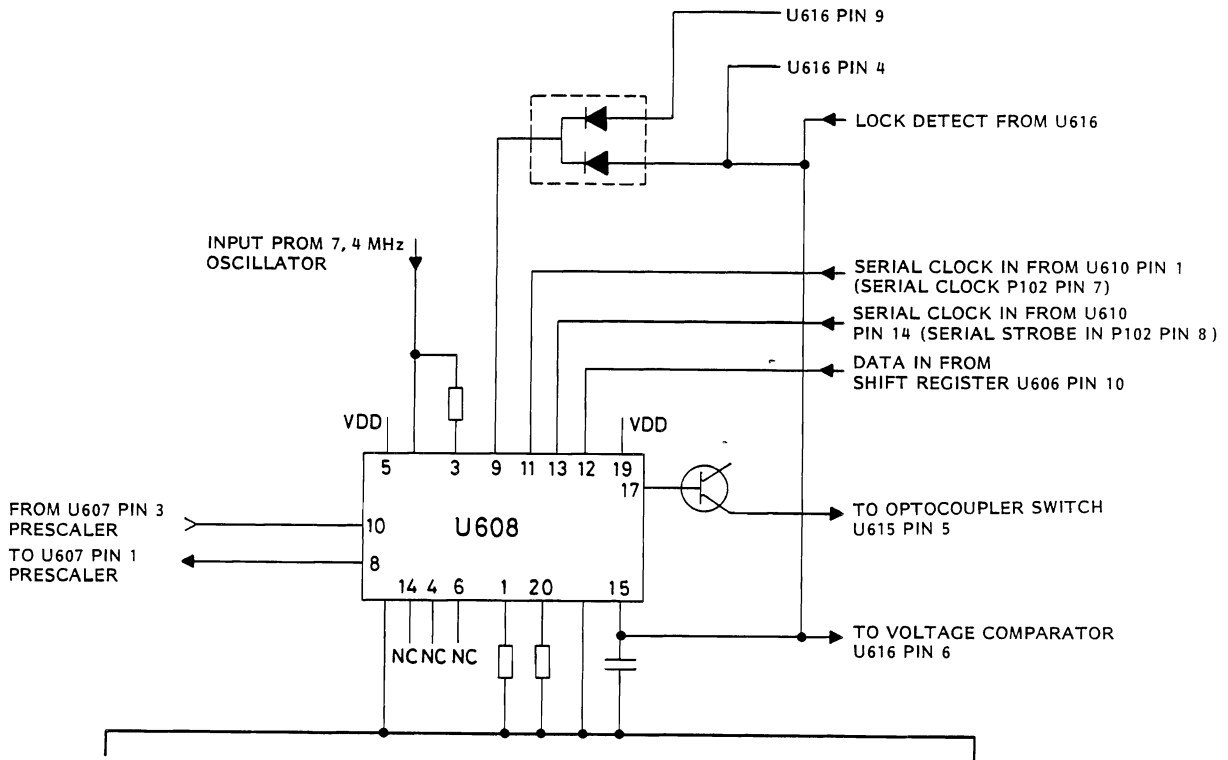

SYNTHESIZER CIRCUIT

The synthesizer chip contains:

- Reference divider (by 1 to 16383).
- Variable divide by N (N = 1 to 1023).
- Variable divide by A (swallow by 1 to 127).
- Sample and hold phase detector.
- Digital frequency detector.
- Out of lock detector.
- Dual modulus control.
- Serial data loading.
- Internal 31 bit latch.

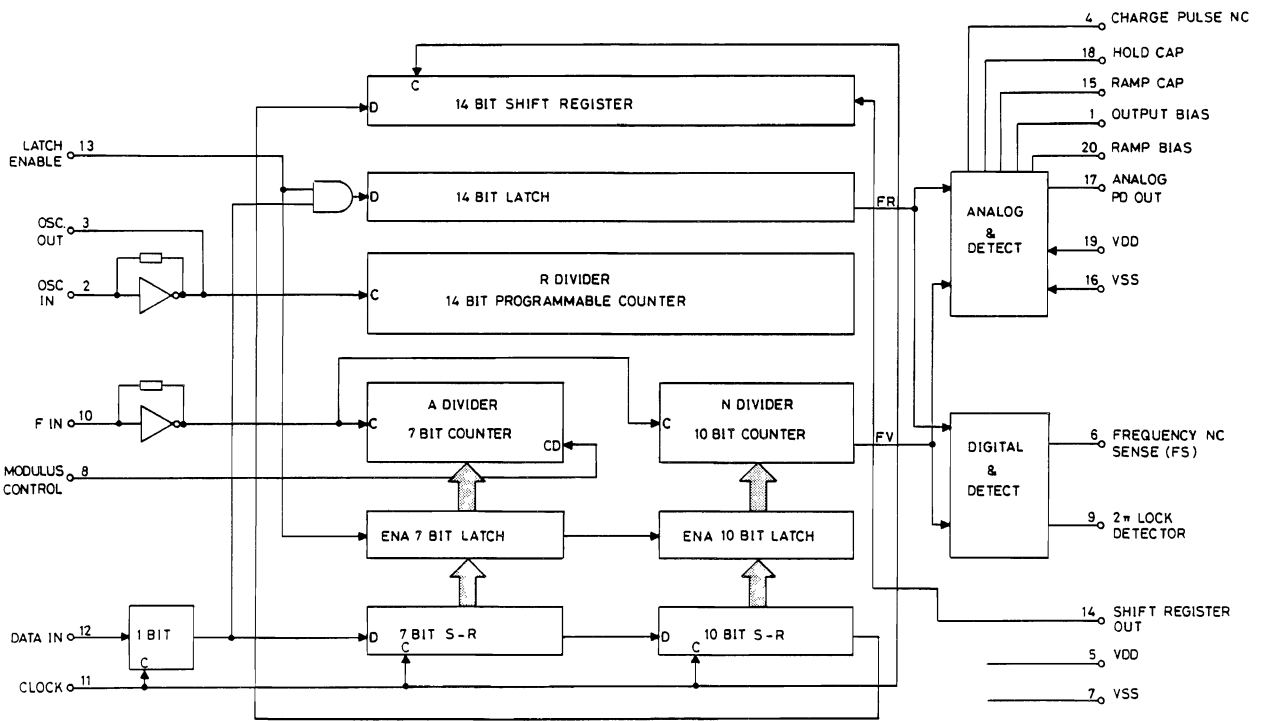

BLOCK DIAGRAM U608

1. Data in - pin 12

The Data is presented on the Data input at the time of the positive clock transition. The Data input provides programming information for the 10 bit + N counter, the 7 bit + A counter, the 14 bit + R counter, and the 1 control bit. The N counter and A counter are latched when the control bit is low and the enable line is high. All counters are latched when the control bit is high and the enable line is high.

2. Lock detect - pin 9

Output B Series Drive Capability.

The output will be high during lock and go low to indicate a non-lock condition. The non-lock condition may be nearly a continuous low or pulses to low. The frequency and duration of the non-lock pulses will be the same as either polarity of the frequency sense output.

3. Modulus control - pin 8

Signal generated by the on chip control logic circuitry for controlling an external dual modulus prescaler. The modulus control level will be low at the beginning of a count cycle and will remain low until the +A counter has counted down from its programmed value. At this time, modulus control goes high and remains high until the +N counter has counted the rest of the way down from its programmed value (N - A additional counts since both +N and +A are counting down during the first portion of the cycle). Modulus control is then set back low, the counters preset to their respective programmed values, and the above sequence repeated. This provides for a total programmable divide value $(N_T) = N.P + A$ where P + 1 and P represent the dual modulus prescaler divide values respectively for low and high modulus control levels; N the number programmed into the +N counter and A the number programmed into the +A counter.

4. F_{in} - pin 10

Input to the positive edge triggers +N and +A counters. F_{in} is derived from the dual modulus prescaler (U602) and is AC coupled.

5. Clock - pin 11

Shift register clock input.

The serial clock comes from the microprocessor U907 on the control logic board CL6002. Each low-to-high transition clocks one bit into the on-chip shift registers. The data is presented on the DATA input at the time of the positive clock transition.

6. Latch enable - pin 13

The enable signal is derived from the serial strobe coming from the microprocessor on the board CL6002. When high ("1") transfers contents of the shift register into the latches, and to the programmable counter inputs. When low ("0") inhibits the above action and thus allows changes to be made in the shift register data without affecting the counter programming and switch outputs. An on-chip pull-up establishes a continuously high level for ENABLE when no external signal is applied.

7. OSC_{out} - pin 3, OSC_{in} - pin 2

OSC_{in} serves as input for the externally-generated reference signal. This signal is AC coupled to OSC_{in} .

8. Ramp cap - pin 15

This is the external connection for the ramp capacity C622 for the sample and hold circuit.

9. Analog PD out (Ramp) - pin 17

In lock, this output delivers DC voltage to the RX VCO.

When out of lock, the ramp voltage passes through the loop filter before being fed into the RX VCO.

The frequency information comes from the CL6002 via the internal serial bus, and is loaded into the latches as a 32 bit block. This data sets up the counter ratios for generating the right output frequency. The phase detector compares the divided frequencies and controls the VCO through an external charge pump and the loop filter.

The frequency synthesizer supplies excitation for the transmitter and local oscillator injection for the receiver mixer.

The synthesizer output covers: The frequency ranges 66.00 to 470.00 MHz.

Receiver first if frequency:

UNIT	DOUBLER	IF (MHz)
RF633x	NO	21.4
RF611x	NO	45
RF6774L	NO	45
RF6774H	NO	45
RF666x	YES	45

The synthesizer output frequency is selected by the serial 40 bit information coming from the CF6xxx board.

Only 32 bits of this telegram is the actual frequency information for the synthesizer. The other bits are used for tuning/tracking voltage generation, RX/TX etc..

(See the curves in adjustment chapter)

Frequency stability is determined by a single crystal controlled reference oscillator operating at 7.4. MHz. (If selfquieting see further in this chapter).

The reference oscillator in RF666x is a separate temperature compensated module (XO6000) while in the other bands it is mounted on the RF printed circuit board.

All reference oscillator (except in RF633x) are equipped with a compromise temperature compensation network consisting of R702, R705, R701, R703, R704, R706.

Synthesizer circuitry in RF6000 employs different reference frequencies and prescaler divide ratios as shown below:

	Ch spacing MHz	CH raster MHz	Phase ref. frequency MHz	Prescaler (P)
RF6332	0.025	0.00625	0.00625	40
RF6333	0.020	0.005	0.005	40
RF6334	0.0125	0.00625	0.00625	40
RF6112	0.025	0.00625	0.00625	64
RF6113	0.020	0.005	0.005	64
RF6114	0.0125	0.00625	0.00625	64
RF6774L	0.0125	0.00625	0.00625	128
RF6774H	0.0125	0.00625	0.00625	128
RF6662	0.025	0.0125	0.00625	64
RF6663	0.020	0.01	0.005	64
RF6664	0.0125	0.00625	0.003125	128

Reference x-tal, standard is 7.4.MHz, but if you want to receive 66.6, 74.0, 81.4, 140.6, 148.0, 155.4, 162.8 or 170.2MHz use 7.375MHz x-tal.

PHASE LOCKED LOOP

The digitally stabilized synthesizer loop consists of a voltage controlled oscillator, a dual modulus prescaler operating at the desired channel raster (except RF6663 which is 1/2 channel raster and RF6664 1/4 channel raster), a phase detector, a low pass filter and a combined out-of-lock detector, speed-up circuitry.

VCO's are separate for receiver (Q601) and transmitter (Q501) and designed around grounded gate FET's.

The receiver VCO is buffered by Q602, Q603 for injection and by Q602, Q604 for prescaler. Similarly the transmitter VCO is buffered by Q502 for injection and by Q502, Q604 for prescaler.

The VCO signal is then applied to the dual modulus prescaler (U607) and variable ratio divider (part of U608) where frequency is divided.

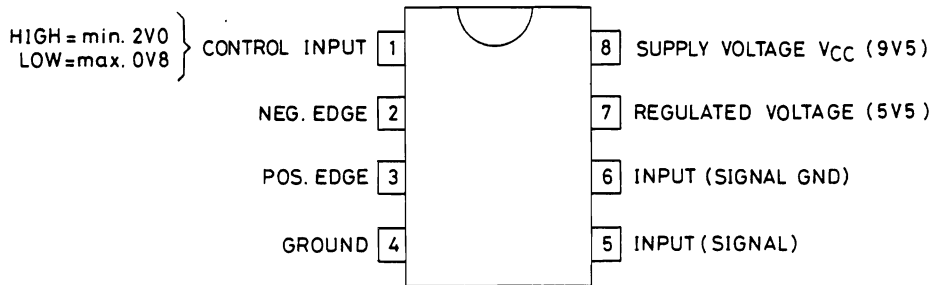

PINNING U607

Frequency and phase discriminator is a "sample and hold" type where C629 is the sample and C628 is the ramp capacitor.

The tuning voltage is generated by sampling the ramp by an internal constant current generator and C628 at time intervals determined by the variable divider.

The Ramp is timed by the reference divider and its slope which gives the phase. The detector gain is tailored by resistors R628 and R629.

The reference divider is also part of the U608.

The output of the phase detector (U608 pin 17) is applied to the emitter follower (Q605) and to the tuning voltage level converter (U609B).

The level converter converts the tuning range of U608, from 1V to 6V to a greater range, from 4V to 20V. This large tuning voltage is required in order to couple relatively low Q varactors lightly to the high Q tuned circuits.

The actual loop filter consists of R638, R639, R608, C642, C640 and C165.

U616 quad comparator, U615 dual optocoupler and U609A are part of the out-of-lock and speed up circuitry.

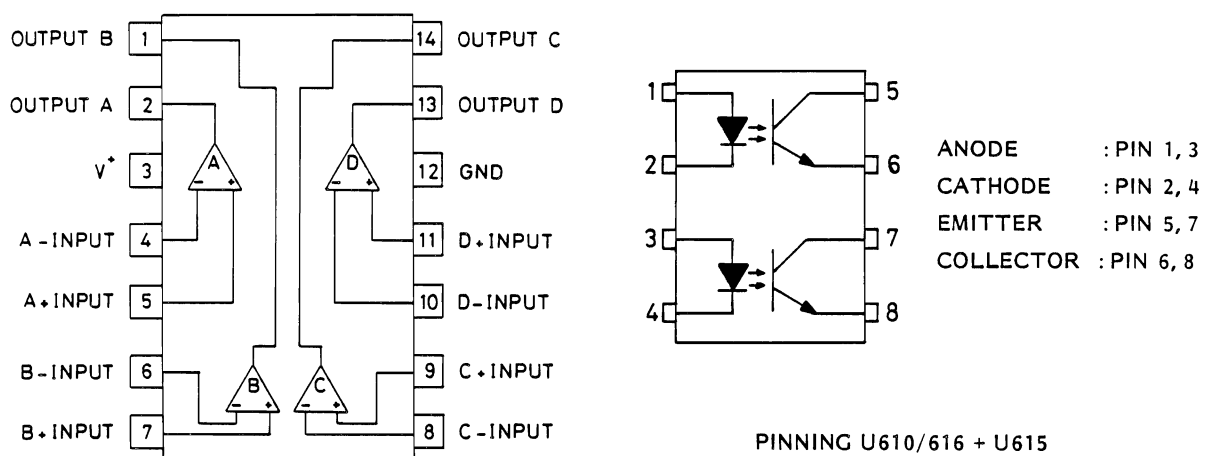

Out-of-lock circuit receives input from:

- 1- Synthesizer out-of-lock pin (608 pin 11)
- 2- Serial enable (via P102 pin 8, U610, D610, R673)
- 3- Ramp voltage (U608 pin 15)

and generates lock signal (U616 pin 13, connected to P102 pin 9) and speed up signal (connected to U609a pin 3).

The lock signal generated by this circuitry is used by CF6001 to turn down the transmitter in case the synthesizer is out of lock.

Speed up signal is used in order to "open" synthesizer, closed loop bandwidth and synchronize reference ramp so that frequency can be changed relatively fast.

The normal closed loop bandwidth is approx. 30 Hz, while in "open" condition is around 600 Hz.

The loop bandwidth is "opened" by short circuiting R638 and R639 loop resistors by aid of the U615 optocoupler.

The ramp synchronization is obtained by short circuiting the U608 pin 2 to ground during the "HIGH" ramp condition so that the 7.4 MHz reference oscillator is not applied to the synthesizer IC and periodic ramp generation is temporarily stopped until synthesizer is near to lock.

Two different parts of the U606 shift register is used as serial to parallel converter.

Clock	Output Enable	Strobe	Data	Parallel Outputs		Serial Outputs	
				Q1	Q _N	Q _S	Q' _S
	0	X	X	3S	3S	Q7	No Chg.
	0	X	X	3S	3S	No Chg.	Q7
	1	0	X	No Chg.	No Chg.	Q7	No Chg.
	1	1	0	0	Q _N - 1	Q7	No Chg.
	1	1	1	1	Q _N - 1	Q7	No Chg.
	1	1	1	No Chg.	No Chg.	No Chg.	Q7

3S = Thre-State

X = Don't Care

At the positive clock edge, information in the 7th shift register stage is transferred to Q8 and Q_S.

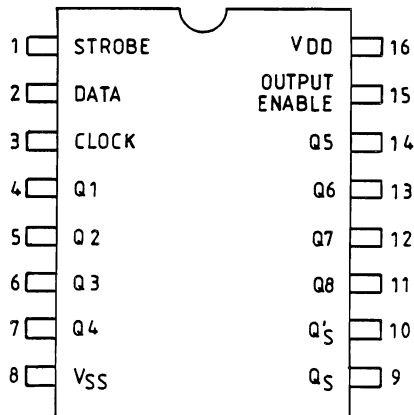

TRUTH TABLE AND PINNING U606

U606 pin 4, 5, 6, 7 are used for VCO control, tracking and modulation compensation networks. The frequency band information is presented at this pins by the last four bits of the telegram.

U606 pin 11, 12, 13 is used for power-up, reduced power and RX/TX respectively.

TRANSMITTER

The transmitter stage consists of an exciter, a power amplifier and a power controller circuit.

EXCITER

The exciter amplifies the TX-VCO output from +3 dBm to about +27 dBm. It is made by three wideband amplifier stages (Q100, Q101, Q102), which covers the whole band. The exciter output is measured between TP10 and TP11.

POWER AMPLIFIER

The PA is made as a three stage amplifier (Q103, Q104, Q105) with a nominal output power level of 22 Watt. It is connected to the duplex filter antenna switch through a lowpass filter.

The DC collector supply on the first stage can be regulated by the power controller circuit and thereby the output power can be reduced by 10 and 20 dB.

POWER CONTROLLER CIRCUIT

There is incorporated a directional coupler for minimizing the influence on output power level caused by changes in PA output VSWR. A small part of the RF output power signal is detected and used as reference for a DC amplifier. The output of this amplifier Q108 is used for regulating the first stage of the PA. This keeps the output power constant against variations in supply voltage and temperature. The circuit includes a temperature sensor (PTC). This PTC circuit will turn down the output power by approx. 3 dB if the internal temperature is higher than 85-90°C.

REGULATOR CIRCUITS

VOLTAGE REGULATORS

There are three different voltages on the RF-board:

8.5 Volt connector is measured at TP13

8.5 Volt TX is measured at TP11

8.5 Volt RX

8.5 Volt:

This voltage is made by a regulator IC (U201) and is used for all the receiver circuits and the interface all circuits but TX and RX.

8.5 Volt TX:

This voltage is used in TX-VCO.

8.5 Volt RX:

This voltage is used in RX-VCO.

SERIAL INTERFACE

This circuit consists of quad comparators (U610) and an 8 bit shift and parts of store register (U606).

The three comparators are used as level shifters from 5 V to 8.5 V for the inputs:

- Serial clock
- Serial data
- Strobe

The comparators are coupled with hysteresis for max. noise immunity. The parallel outputs from the shift register are used to control:

- 3 power levels
- TX ON/OFF
- Synthesizer enable.

The serial out goes to the synthesizer chip for loading frequency information.

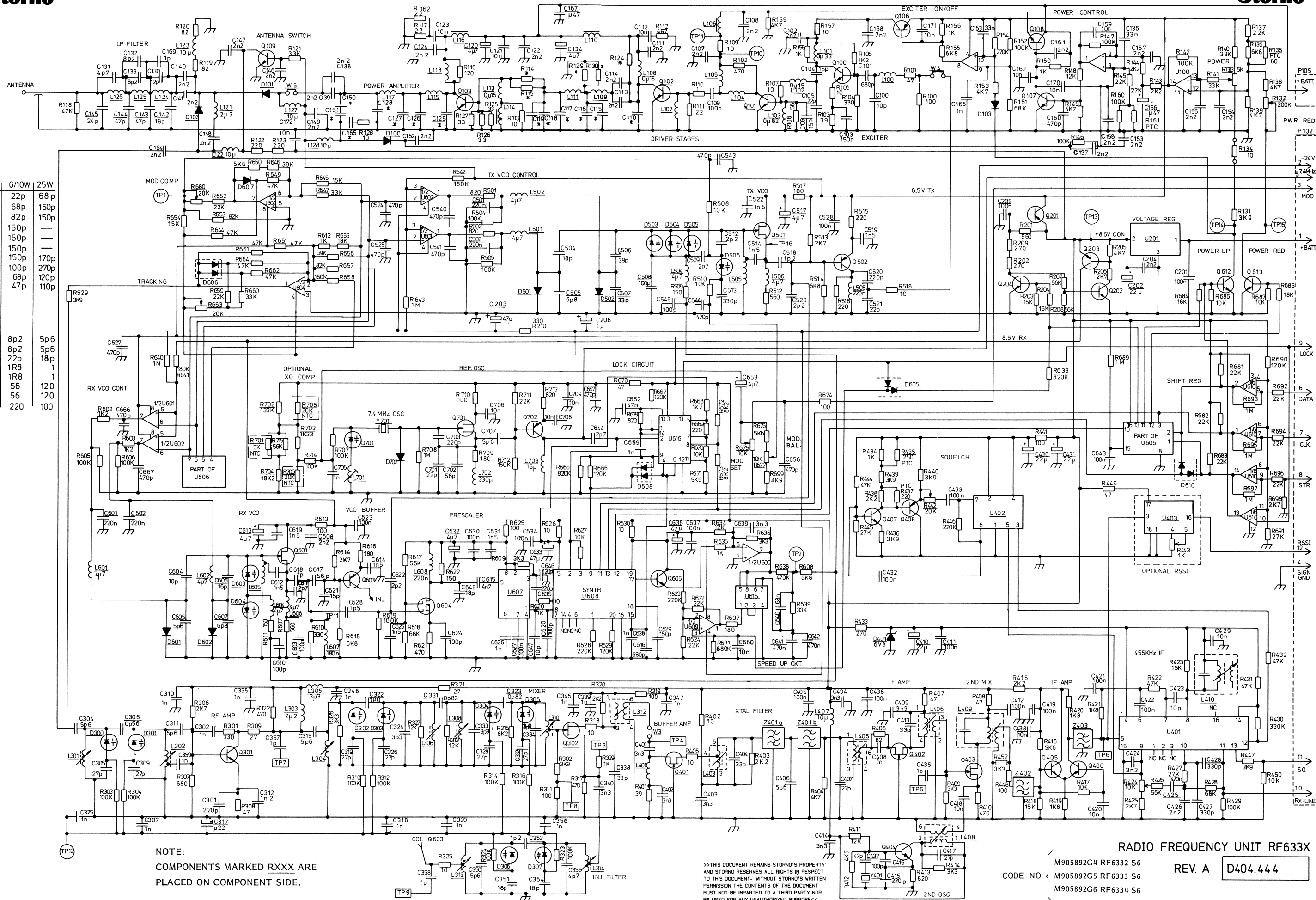

NOTE:
COMPONENTS MARKED RXXX ARE
PLACED ON COMPONENT SIDE.

>>>THIS DOCUMENT REMAINS STORNO'S PROPERTY
AND STORNO RESERVES ALL RIGHTS IN RESPECT
TO THIS DOCUMENT. WITHOUT STORNO'S WRITTEN
PERMISSION THE CONTENTS OF THE DOCUMENT
MUST NOT BE IMPARTED TO A THIRD PARTY NOR
BE USED FOR ANY UNAUTHORIZED PURPOSE<<<

RADIO FREQUENCY UNIT RF633X

CODE NO. M905892G4 RF6332 S6
M905892G5 RF6333 S6
M905892G6 RF6334 S6

REV. A D404.444

Storno

Storno

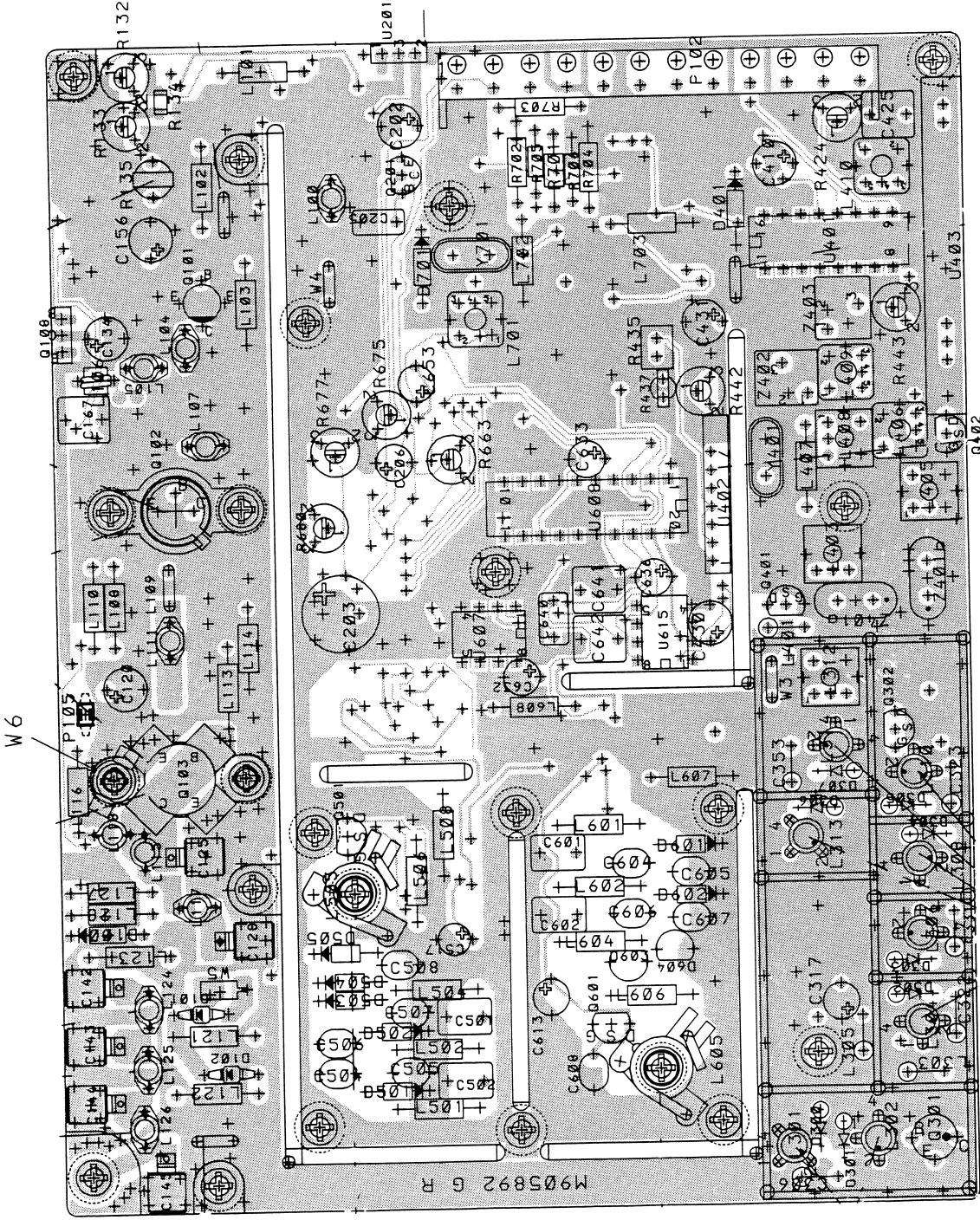

RADIO FREQUENCY UNIT RF633X
COMPONENT LAYOUT - COMPONENT SIDE

M905892G4 RF6332 S6
M905892G5 RF6333 S6
M905892G6 RF6334 S6

CODE NO.

REV. 2

D404.445

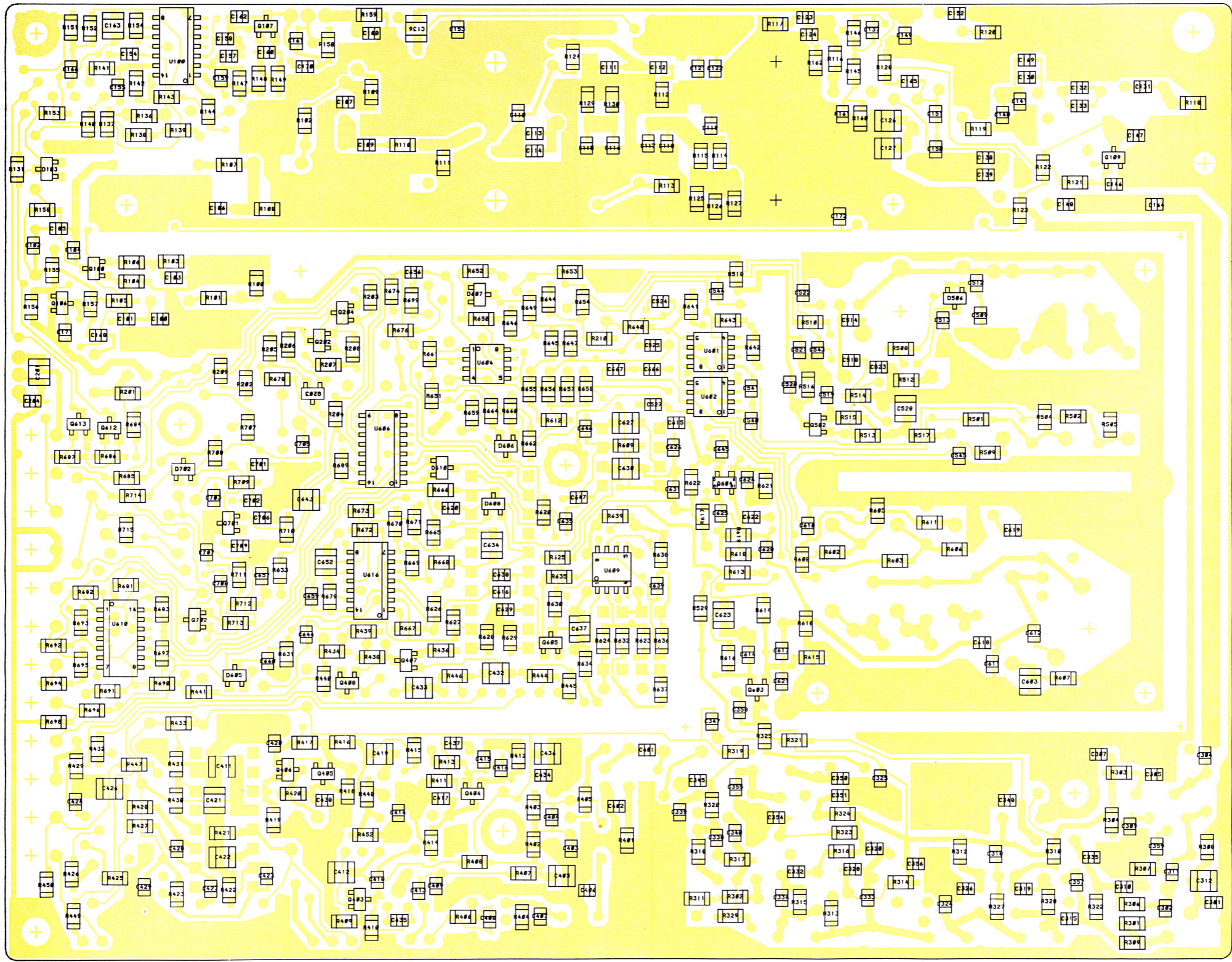

CODE NO. { M905892G4 RF6332 S6
 M905892G5 RF6333 S6
 M905892G6 RF6334 S6

RADIO FREQUENCY UNIT RF633X
 COMPONENT LAYOUT - CHIP SIDE

REV. 2 D404.446

Pos.	Code No.	Description	Qt.
C00	J707444P4	CAP TA SOL 1U 20% 35V	1
C000	A700233P9	CAP CER CL2 2N2 20% 50V	1
C100	J707809P13	CAP CER NPO 10P 5% 50V	1
C101	J707438P4	CAP CER CL2 680P 10% 50V	1
C102	J707438P7	CAP CER CL2 2N2 10% 50V	1
C103	J707436P65	CAP CER NPO 150P 5% 50V	1
C104	J707809P15	CAP CER NPO 15P 5% 50V	1
C105	J707809P17	CAP CER NPO 22P 5% 50V	1
C106	J707809P15	CAP CER NPO 15P 5% 50V	1
C107	J707438P7	CAP CER CL2 2N2 10% 50V	1
C108	J707438P7	CAP CER CL2 2N2 10% 50V	1
C109	J707809P25	CAP CER NPO 100P 5% 50V	1
C110	J707809P17	CAP CER NPO 22P 5% 50V	1
C111	J707438P7	CAP CER CL2 2N2 10% 50V	1
C112	J707438P14	CAP CER CL2 10N 10% 50V	1
C113	J707438P7	CAP CER CL2 2N2 10% 50V	1
C114	J707438P7	CAP CER CL2 2N2 10% 50V	1
C115	J707809P23	CAP CER NPO 68P 5% 50V	1
C116	J707809P24	CAP CER NPO 82P 5% 50V	1
C117	J707809P27	CAP CER NPO 150P 5% 50V	1
C118	J707809P27	CAP CER NPO 150P 5% 50V	1
C119	J707809P27	CAP CER NPO 150P 5% 50V	1
C120	J707353P6	CAP ELECT 4U7 20% 25V	1
C121	J707438P14	CAP CER CL2 10N 10% 50V	1
C122	J707438P7	CAP CER CL2 2N2 10% 50V	1
C123	J707438P14	CAP CER CL2 10N 10% 50V	1
C124	J707438P7	CAP CER CL2 2N2 10% 50V	1
C125	A700006P38	CAP MICA 150P 5% 100V	1
C126	J709524P49	CAP CER RF 100P 5% 100V	1
C127	J709524P45	CAP CER RF 68P 5% 100V	1
C128	A700006P26	CAP MICA 47P 5% 100V	1
C130	J707809P14	CAP CER NPO 12P 5% 50V	1
C131	J707809P9	CAP CER NPO 4P7 ,25P 50V	1
C132	J707809P12	CAP CER NPO 8P2 ,25P 50V	1
C133	J707809P12	CAP CER NPO 8P2 ,25P 50V	1
C134	J707353P6	CAP ELECT 4U7 20% 25V	1

Pos.	Code No.	Description	Qt.
C136	J707438P20	CAP CER CL2 33N 10% 50V	1
C137	J707436P77	CAP CER NPO 470P 5% 50V	1
C138	J707438P7	CAP CER CL2 2N2 10% 50V	1
C139	J707438P7	CAP CER CL2 2N2 10% 50V	1
C140	J707438P7	CAP CER CL2 2N2 10% 50V	1
C141	J707438P7	CAP CER CL2 2N2 10% 50V	1
C142	A700006P17	CAP MICA 22P 5% 100V	1
C143	A700006P24	CAP MICA 43P 5% 100V	1
C144	A700006P27	CAP MICA 51P 5% 100V	1
C145	A700006P20	CAP MICA 30P 5% 100V	1
C146	J707438P7	CAP CER CL2 2N2 10% 50V	1
C147	J707438P7	CAP CER CL2 2N2 10% 50V	1
C148	J707438P7	CAP CER CL2 2N2 10% 50V	1
C149	J707438P7	CAP CER CL2 2N2 10% 50V	1
C150	J707809P12	CAP CER NPO 8P2 ,25P 50V	1
C151	J707809P13	CAP CER NPO 10P 5% 50V	1
C152	J707438P7	CAP CER CL2 2N2 10% 50V	1
C153	J707438P7	CAP CER CL2 2N2 10% 50V	1
C154	J707438P7	CAP CER CL2 2N2 10% 50V	1
C155	J707438P7	CAP CER CL2 2N2 10% 50V	1
C156	J707353P3	CAP ELECT OU47 20% 50V	1
C157	J707438P7	CAP CER CL2 2N2 10% 50V	1
C158	J707438P7	CAP CER CL2 2N2 10% 50V	1
C159	J707438P14	CAP CER CL2 10N 10% 50V	1
C160	J707438P7	CAP CER CL2 2N2 10% 50V	1
C161	J707438P7	CAP CER CL2 2N2 10% 50V	1
C162	J707438P14	CAP CER CL2 10N 10% 50V	1
C163	J707438P26	CAP CER CL2 100N 10% 50V	1
C164	J707438P7	CAP CER CL2 2N2 10% 50V	1
C165	J707809P17	CAP CER NPO 22P 5% 50V	1
C167	J707412P13	CAP PYES 470N 10% 63V	1
C168	J707438P7	CAP CER CL2 2N2 10% 50V	1
C169	J707809P1	CAP CER NPO 1P0 ,25P 50V	1
C170	A700234P7	CAP PYES 10N 10% 50V	1
C171	J707438P14	CAP CER CL2 10N 10% 50V	1
C201	J707438P26	CAP CER CL2 100N 10% 50V	1

Pos.	Code No.	Description	Qt.
C202	J707444P8	CAP TA SOL 22U 20% 16V	1
C203	J706005P12	CAP ELECT 47U +100-10%	1
C205	J707412P9	CAP PYES 100N 10% 63V	1
C301	J707436P69	CAP CER NPO 220P 5% 50V	1
C302	J707438P5	CAP CER CL2 1N 10% 50V	1
C304	J707436P10	CAP CER NPO 5P6.25P 50V	1
C305	J707436P33	CAP CER NPO 27P 5% 50V	1
C306	J707483P4	CAP PHEN OP56 5% 500V	1
C307	J707438P5	CAP CER CL2 1N 10% 50V	1
C309	J707436P33	CAP CER NPO 27P 5% 50V	1
C310	J707438P5	CAP CER CL2 1N 10% 50V	1
C311	J707436P10	CAP CER NPO 5P6.25P 50V	1
C312	J707436P87	CAP CER NPO 1N2 5% 50V	1
C315	J707436P10	CAP CER NPO 5P6.25P 50V	1
C317	J707444P2	CAP TA SOL OU22 20% 35V	1
C318	J707438P5	CAP CER CL2 1N 10% 50V	1
C319	J707436P33	CAP CER NPO 27P 5% 50V	1
C320	J707438P5	CAP CER CL2 1N 10% 50V	1
C322	J707483P7	CAP PHEN 1P00 5% 500V	1
C323	J707483P6	CAP PHEN OP82 5% 500V	1
C324	J707436P7	CAP CER NPO 3P3,25P 50V	1
C325	J707438P5	CAP CER CL2 1N 10% 50V	1
C326	J707436P33	CAP CER NPO 27P 5% 50V	1
C328	J707436P33	CAP CER NPO 27P 5% 50V	1
C331	J707483P6	CAP PHEN OP82 5% 500V	1
C332	J707436P33	CAP CER NPO 27P 5% 50V	1
C333	J707436P7	CAP CER NPO 3P3,25P 50V	1
C334	J707436P8	CAP CER NPO 3P9,25P 50V	1
C335	J707438P5	CAP CER CL2 1N 10% 50V	1
C338	J707436P37	CAP CER NPO 33P 5% 50V	1
C339	J707438P5	CAP CER CL2 1N 10% 50V	1
C340	J707438P8	CAP CER CL2 3N3 10% 50V	1
C345	J707438P5	CAP CER CL2 1N 10% 50V	1
C347	J707438P5	CAP CER CL2 1N 10% 50V	1
C348	J707438P5	CAP CER CL2 1N 10% 50V	1
C350	J707436P10	CAP CER NPO 5P6.25P 50V	1

Pos.	Code No.	Description	Qt.
C351	J707436P25	CAP CER NPO 18P 5% 50V	1
C353	J707483P8	CAP PHEN 1P20 5% 500V	1
C354	J707436P25	CAP CER NPO 18P 5% 50V	1
C355	J707436P9	CAP CER NPO 4P7,25P 50V	1
C356	J707438P5	CAP CER CL2 1N 10% 50V	1
C357	J707436P1	CAP CER NPO 1P0.25P 50V	1
C358	J707436P1	CAP CER NPO 1P0.25P 50V	1
C359	J707438P5	CAP CER CL2 1N 10% 50V	1
C401	J707438P8	CAP CER CL2 3N3 10% 50V	1
C402	J707438P8	CAP CER CL2 3N3 10% 50V	1
C403	J707438P8	CAP CER CL2 3N3 10% 50V	1
C404	J707436P37	CAP CER NPO 33P 5% 50V	1
C405	J707438P26	CAP CER CL2 100N 10% 50V	1
C406	J707436P10	CAP CER NPO 5P6.25P 50V	1
C407	J707436P33	CAP CER NPO 27P 5% 50V	1
C408	J707438P5	CAP CER CL2 1N 10% 50V	1
C409	J707438P8	CAP CER CL2 3N3 10% 50V	1
C410	J707444P8	CAP TA SOL 22U 20% 16V	1
C411	J707438P26	CAP CER CL2 100N 10% 50V	1
C412	J707438P26	CAP CER CL2 100N 10% 50V	1
C413	J707436P37	CAP CER NPO 33P 5% 50V	1
C414	J707438P8	CAP CER CL2 3N3 10% 50V	1
C415	J707436P69	CAP CER NPO 220P 5% 50V	1
C416	J707436P61	CAP CER NPO 100P 5% 50V	1
C417	J707436P33	CAP CER NPO 27P 5% 50V	1
C418	J707438P14	CAP CER CL2 10N 10% 50V	1
C419	J707438P26	CAP CER CL2 100N 10% 50V	1
C420	J707438P14	CAP CER CL2 10N 10% 50V	1
C421	J707438P26	CAP CER CL2 100N 10% 50V	1
C422	J707438P26	CAP CER CL2 100N 10% 50V	1
C423	J707436P13	CAP CER NPO 10P 5% 50V	1
C424	J707438P8	CAP CER CL2 3N3 10% 50V	1
C425	J707412P13	CAP PYES 470N 10% 63V	1
C426	J707436P93	CAP CER NPO 2N2 5% 50V	1
C427	J707436P73	CAP CER NPO 330P 5% 50V	1
C428	J707436P73	CAP CER NPO 330P 5% 50V	1

Storno

Pos.	Code No.	Description	Qt.
C429	J707438P14	CAP CER CL2 10N 10% 50V	1
C430	J707444P8	CAP TA SOL 22U 20% 16V	1
C431	J707444P8	CAP TA SOL 22U 20% 16V	1
C432	J707438P26	CAP CER CL2 100N 10% 50V	1
C433	J707438P26	CAP CER CL2 100N 10% 50V	1
C434	J707438P8	CAP CER CL2 3N3 10% 50V	1
C435	J707436P1	CAP CER NPO 1P0.25P 50V	1
C436	J707438P26	CAP CER CL2 100N 10% 50V	1
C437	J707436P45	CAP CER NPO 47P 5% 50V	1
C501	J707412P11	CAP PYES 220N 10% 63V	1
C502	J707412P11	CAP PYES 220N 10% 63V	1
C504	A700235P16	CAP CER N150 18P 5% 50V	1
C505	A700235P11	CAP CER N150 6P8.25P 50V	1
C506	A700235P20	CAP CER N150 39P 5% 50V	1
C507	A700235P19	CAP CER N150 33P 5% 50V	1
C508	A700235P25	CAP CER N150 100P 5% 50V	1
C509	J707436P6	CAP CER NPO 2P7,25P 50V	1
C512	J707436P5	CAP CER NPO 2P2.25P 50V	1
C513	J707438P2	CAP CER CL2 330P 10% 50V	1
C514	J707438P6	CAP CER CL2 1N5 10% 50V	1
C517	J707444P6	CAP TA SOL 4U7 20% 35V	1
C518	J707436P2	CAP CER NPO 1P2,25% 50V	1
C519	J707438P6	CAP CER CL2 1N5 10% 50V	1
C520	J707436P69	CAP CER NPO 220P 5% 50V	1
C521	J707436P29	CAP CER NPO 22P 5% 50V	1
C522	J707438P6	CAP CER CL2 1N5 10% 50V	1
C523	J707436P5	CAP CER NPO 2P2.25P 50V	1
C524	J707438P3	CAP CER CL2 470P 10% 50V	1
C525	J707438P3	CAP CER CL2 470P 10% 50V	1
C527	J707438P3	CAP CER CL2 470P 10% 50V	1
C528	J707438P26	CAP CER CL2 100N 10% 50V	1
C540	J707438P3	CAP CER CL2 470P 10% 50V	1
C541	J707438P3	CAP CER CL2 470P 10% 50V	1
C543	J707438P3	CAP CER CL2 470P 10% 50V	1
C544	J707438P3	CAP CER CL2 470P 10% 50V	1
C545	J707436P61	CAP CER NPO 100P 5% 50V	1

Storno

Pos.	Code No.	Description	Qt.
C601	J707412P11	CAP PYES 220N 10% 63V	1
C602	J707412P11	CAP PYES 220N 10% 63V	1
C603	J707438P26	CAP CER CL2 100N 10% 50V	1
C604	A700235P13	CAP CER N150 10P 5% 50V	1
C605	A700235P10	CAP CER N150 5P6.25P 50V	1
C606	A700235P38	CAP CER N150 16P 5% 50V	1
C607	A700235P11	CAP CER N150 6P8.25P 50V	1
C610	J707436P61	CAP CER NPO 100P 5% 50V	1
C612	J707438P6	CAP CER CL2 1N5 10% 50V	1
C613	J707444P6	CAP TA SOL 4U7 20% 35V	1
C614	J707438P6	CAP CER CL2 1N5 10% 50V	1
C615	J707438P10	CAP CER CL2 4N7 10% 50V	1
C616	J707438P4	CAP CER CL2 680P 10% 50V	1
C617	J707436P49	CAP CER NPO 56P 5% 50V	1
C618	J707436P1	CAP CER NPO 1P0.25P 50V	1
C619	J707438P6	CAP CER CL2 1N5 10% 50V	1
C620	J707436P61	CAP CER NPO 100P 5% 50V	1
C621	J707436P21	CAP CER NPO 15P 5% 50V	1
C622	J707436P5	CAP CER NPO 2P2.25P 50V	1
C623	J707438P26	CAP CER CL2 100N 10% 50V	1
C624	J707436P61	CAP CER NPO 100P 5% 50V	1
C625	J707438P6	CAP CER CL2 1N5 10% 50V	1
C626	J707438P5	CAP CER CL2 1N 10% 50V	1
C627	J707438P26	CAP CER CL2 100N 10% 50V	1
C628	J707436P3	CAP CER NPO 1P5,25P 50V	1
C629	J707436P65	CAP CER NPO 150P 5% 50V	1
C630	J707438P26	CAP CER CL2 100N 10% 50V	1
C631	J707438P6	CAP CER CL2 1N5 10% 50V	1
C632	J707444P6	CAP TA SOL 4U7 20% 35V	1
C633	J707444P17	CAP TA SOL 47U 20% 10V	1
C634	J707438P26	CAP CER CL2 100N 10% 50V	1
C635	J707438P1	CAP CER CL2 220P 10% 50V	1
C636	J707444P17	CAP TA SOL 47U 20% 10V	1
C637	J707438P26	CAP CER CL2 100N 10% 50V	1
C638	J707438P5	CAP CER CL2 1N 10% 50V	1
C639	J707438P8	CAP CER CL2 3N3 10% 50V	1

Pos.	Code No.	Description	Qt.
C640	J707412P8	CAP PYES 68N 10% 63V	1
C641	J707412P13	CAP PYES 470N 10% 63V	1
C642	J707412P13	CAP PYES 470N 10% 63V	1
C643	J707438P26	CAP CER CL2 100N 10% 50V	1
C644	J707436P6	CAP CER NPO 2P7,25P 50V	1
C645	J707436P25	CAP CER NPO 18P 5% 50V	1
C646	J707436P63	CAP CER NPO 120P 5% 50V	1
C647	J707436P13	CAP CER NPO 10P 5% 50V	1
C652	J707438P22	CAP CER CL2 47N 10% 50V	1
C653	J707444P6	CAP TA SOL 4U7 20% 35V	1
C656	J707438P3	CAP CER CL2 470P 10% 50V	1
C657	J707438P3	CAP CER CL2 470P 10% 50V	1
C659	J707438P5	CAP CER CL2 1N 10% 50V	1
C660	J707438P14	CAP CER CL2 10N 10% 50V	1
C666	J707438P3	CAP CER CL2 470P 10% 50V	1
C667	J707438P3	CAP CER CL2 470P 10% 50V	1
C701	J707436P29	CAP CER NPO 22P 5% 50V	1
C702	J708702P22	CAP CER N750 56P 5% 50V	1
C703	J707436P69	CAP CER NPO 220P 5% 50V	1
C705	J707438P5	CAP CER CL2 1N 10% 50V	1
C706	J707438P14	CAP CER CL2 10N 10% 50V	1
C707	J707436P10	CAP CER NPO 5P6.25P 50V	1
C708	J707438P14	CAP CER CL2 10N 10% 50V	1
C709	J707438P14	CAP CER CL2 10N 10% 50V	1
D100	A700047P3	DIO SI SIG 1N6263	1
D101	J706892P1	DIO SI PIN UM 9401	1
D102	J706892P1	DIO SI PIN UM 9401	1
D103	J707390P1	DIO SI SIG BAV 74	1
D300	J707928P2	DIO SI CAP BB 809	1
D301	J707928P2	DIO SI CAP BB 809	1
D302	J707928P2	DIO SI CAP BB 809	1
D303	J707928P2	DIO SI CAP BB 809	1
D304	J707928P2	DIO SI CAP BB 809	1
D305	J707928P2	DIO SI CAP BB 809	1
D306	J707928P2	DIO SI CAP BB 809	1
D307	J707928P2	DIO SI CAP BB 809	1

Pos.	Code No.	Description	Qt.
D401	A700025P8	DIO SI ZENR 6V8 5% 0,4W	1
D501	J707928P2	DIO SI CAP BB 809	1
D502	J707928P2	DIO SI CAP BB 809	1
D503	J707928P2	DIO SI CAP BB 809	1
D504	J707928P2	DIO SI CAP BB 809	1
D505	J707928P2	DIO SI CAP BB 809	1
D506	J707397P1	DIO SI CAP BBY 40	1
D601	J707928P2	DIO SI CAP BB 809	1
D602	J707928P2	DIO SI CAP BB 809	1
D603	J709536P1	DIO SI CAP MV2111	1
D604	J709536P1	DIO SI CAP MV2111	1
D605	J707389P1	DIO SI SIG BAV 99	1
D606	J708681P1	DIO SI SIG BAW 56	1
D607	J707390P1	DIO SI SIG BAV 74	1
D608	J707390P1	DIO SI SIG BAV 74	1
D610	J708681P1	DIO SI SIG BAW 56	1
D701	A700073P1	DIO SI CAP BB 409	1
D702	J707390P1	DIO SI SIG BAV 74	1
L100	K805653G9	COIL ASM 9 1/2T	1
L101	A700024P7	COIL RF FIX 0.33UH 10%	1
L102	A700024P3	COIL RF FIX 0.15UH 10%	1
L103	A700024P12	COIL RF FIX 0.82UH 10%	1
L104	K805653G2	COIL ASM 2 1/2T	1
L105	K805653G8	COIL ASM 8 1/2T	1
L106	J707339G1	COIL FIX ASM	1
L107	K805653G4	COIL ASM 4 1/2T	1
L108	A700024P3	COIL RF FIX 0.15UH 10%	1
L109	J707256P1	COIL FIX	1
L110	J709287P1	CORE TOROIDAL FERR	1
L111	K805653G1	COIL ASM 1 1/2T	1
L113	A700024P3	COIL RF FIX 0.15UH 10%	1
L114	J709287P1	CORE TOROIDAL FERR	1
L115	J707426P2.	COIL FIX	1
L116	J709287P1	CORE TOROIDAL FERR	1
L117	K805653G6	COIL ASM 6 1/2T	1
L118	J707426P6	COIL FIX	1

Pos.	Code No.	Description	Qt.
L121	A700024P18	COIL RF FIX 2.7UH 10%	1
L122	A700024P25	COIL RF FIX 10.0UH 10%	1
L123	A700024P25	COIL RF FIX 10.0UH 10%	1
L124	K805653G7	COIL ASM 7 1/2 T	1
L125	K805653G7	COIL ASM 7 1/2 T	1
L126	K805653G9	COIL ASM 9 1/2T	1
L127	A700024P25	COIL RF FIX 10.0UH 10%	1
L128	A700024P25	COIL RF FIX 10.0UH 10%	1
L301	J709099P8	COIL RF VAR 7 1/2T	1
L302	J709099P15	COIL RF VAR 7 1/2T TAP	1
L303	J707486P11	COIL RF FIX 2.2UH 10%	1
L304	J709099P8	COIL RF VAR 7 1/2T	1
L305	J707486P2	COIL RF FIX 3.3UH 10%	1
L306	J709099P8	COIL RF VAR 7 1/2T	1
L308	J709099P8	COIL RF VAR 7 1/2T	1
L310	J709099P9	COIL RF VAR 7 1/2T TAP	1
L312	J708428P1	COIL RF VAR 45 MHZ	1
L313	J709099P12	COIL RF VAR 5 1/2T TAP	1
L314	J709099P14	COIL RF VAR 5 1/2T	1
L401	J707486P3	COIL RF FIX 6.8UH 10%	1
L403	K805570G6	COIL ASM	1
L405	J708428P1	COIL RF VAR 45 MHZ	1
L406	K805570G5	COIL ASM	1
L407	A700024P25	COIL RF FIX 10.0UH 10%	1
L408	J708428P1	COIL RF VAR 45 MHZ	1
L409	J707431P1	COIL RF VAR 455KHZ 25%	1
L410	J707431P1	COIL RF VAR 455KHZ 25%	1
L501	A700024P21	COIL RF FIX 4.7UH 10%	1
L502	A700024P21	COIL RF FIX 4.7UH 10%	1
L504	A700024P21	COIL RF FIX 4.7UH 10%	1
L505	L855671P2	COIL RADIO FREQUENCY	1
L506	A700024P21	COIL RF FIX 4.7UH 10%	1
L508	A700024P5	COIL RF FIX 0.22UH 10%	1
L601	A700024P21	COIL RF FIX 4.7UH 10%	1
L602	A700024P21	COIL RF FIX 4.7UH 10%	1
L604	A700024P21	COIL RF FIX 4.7UH 10%	1

Pos.	Code No.	Description	Qt.
L605	L855671P2	COIL RADIO FREQUENCY	1
L606	A700024P21	COIL RF FIX 4.7UH 10%	1
L607	A700024P4	COIL RF FIX 0.18UH 10%	1
L608	A700024P5	COIL RF FIX 0.22UH 10%	1
L701	K805570G7	COIL ASM	1
L702	A700024P43	COIL RF FIX 330UH 10%	1
L703	A700024P27	COIL RF FIX 15.0UH 10%	1
P102	J707064P112	CONN PWB FEM 12-CKT	1
P105	A701883P4	CONT EL	1
Q100	J707388P1	TSTR NPN SI BFR 53	1
Q101	A701940P1	TSTR NPN SI RF-PWR 0.4W	1
Q102	J709517P1	TSTR NPN SI RF-PWR BFQ 43	1
Q103	J709163P1	TSTR NPN SI RF-PWR 10W	1
Q106	J707432P1	TSTR PNP SI BCX 18	1
Q107	J707386P1	TSTR NPN SI BCW 32	1
Q108	J708406P1	TSTR SI NPN BD 233	1
Q109	J707386P1	TSTR NPN SI BCW 32	1
Q201	J707435P1	TSTR PNP SI BC 369	1
Q202	J707386P1	TSTR NPN SI BCW 32	1
Q203	J707432P1	TSTR PNP SI BCX 18	1
Q204	J707386P1	TSTR NPN SI BCW 32	1
Q301	J706011P2	TSTR NPN SI BFR 91A	1
Q302	J707817P1	TSTR JFET SI J 309	1
Q401	J707817P1	TSTR JFET SI J 309	1
Q402	J707817P1	TSTR JFET SI J 309	1
Q403	J707419P1	TSTR JFET SI BF 511	1
Q404	J708418P1	TSTR NPN SI BFS 20	1
Q405	J708418P1	TSTR NPN SI BFS 20	1
Q406	J708418P1	TSTR NPN SI BFS 20	1
Q407	J707386P1	TSTR NPN SI BCW 32	1
Q408	J707387P1	TSTR PNP SI BCW 30	1
Q501	J707817P1	TSTR JFET SI J 309	1
Q502	J708318P1	TSTR PNP SI BFT 92	1
Q601	J707817P1	TSTR JFET SI J 309	1
Q603	J708318P1	TSTR PNP SI BFT 92	1
Q604	J707433P1	TSTR MFET SI BF 989	1

Pos.	Code No.	Description	Qt.
Q605	J707386P1	TSTR NPN SI BCW 32	1
Q612	J707386P1	TSTR NPN SI BCW 32	1
Q613	J707386P1	TSTR NPN SI BCW 32	1
Q701	J707419P1	TSTR JFET SI BF 511	1
Q702	J707387P1	TSTR PNP SI BCW 30	1
R000	J707385P332	RES MFILM 3K3 5% 1/8W	1
R100	J707385P101	RES MFILM 100R 5% 1/8W	1
R101	J707385P100	RES MFILM 10R 5% 1/8W	1
R102	J707385P471	RES MFILM 470R 5% 1/8W	1
R103	J707385P390	RES MFILM 39R 5% 1/8W	1
R104	J707385P331	RES MFILM 330R 5% 1/8W	1
R105	J707385P122	RES MFILM 1K2 5% 1/8W	1
R106	J707385P100	RES MFILM 10R 5% 1/8W	1
R107	J707385P100	RES MFILM 10R 5% 1/8W	1
R108	J707385P560	RES MFILM 56R 5% 1/8W	1
R109	J707385P910	RES MFILM 1R0 20% 1/8W	1
R110	J707385P910	RES MFILM 1R0 20% 1/8W	1
R111	J707385P220	RES MFILM 22R 5% 1/8W	1
R112	J707385P947	RES MFILM 4R7 20% 1/8W	1
R113	J707385P100	RES MFILM 10R 5% 1/8W	1
R114	J707385P918	RES MFILM 1R8 20% 1/8W	1
R115	J707385P918	RES MFILM 1R8 20% 1/8W	1
R116	J707385P121	RES MFILM 120R 5% 1/8W	1
R117	J707385P100	RES MFILM 10R 5% 1/8W	1
R118	J707385P473	RES MFILM 47K 5% 1/8W	1
R119	J707385P820	RES MFILM 82R 5% 1/8W	1
R120	J707385P820	RES MFILM 82R 5% 1/8W	1
R121	J707385P333	RES MFILM 33K 5% 1/8W	1
R122	J707385P221	RES MFILM 220R 5% 1/8W	1
R123	J707385P221	RES MFILM 220R 5% 1/8W	1
R124	J707385P221	RES MFILM 220R 5% 1/8W	1
R125	J707385P330	RES MFILM 33R 5% 1/8W	1
R126	J707385P330	RES MFILM 33R 5% 1/8W	1
R127	J707385P330	RES MFILM 33R 5% 1/8W	1
R128	J707385P100	RES MFILM 10R 5% 1/8W	1
R129	J707385P470	RES MFILM 47R 5% 1/8W	1

Pos.	Code No.	Description	Qt.
R130	J707385P470	RES MFILM 47R 5% 1/8W	1
R131	J707385P392	RES MFILM 3K9 5% 1/8W	1
R132	J708538P9	RES VAR CER 200K 20% 0,5W	1
R133	J708538P4	RES VAR CER 5K 20% 0,5W	1
R134	J707385P100	RES MFILM 10R 5% 1/8W	1
R135	J706147P2	RES THERM PTC 80R 25%	1
R136	J707385P682	RES MFILM 6K8 5% 1/8W	1
R137	J707385P223	RES MFILM 22K 5% 1/8W	1
R138	J707385P472	RES MFILM 4K7 5% 1/8W	1
R139	J707385P472	RES MFILM 4K7 5% 1/8W	1
R140	J707385P333	RES MFILM 33K 5% 1/8W	1
R141	J707385P333	RES MFILM 33K 5% 1/8W	1
R142	J707385P104	RES MFILM 100K 5% 1/8W	1
R143	J707385P222	RES MFILM 2K2 5% 1/8W	1
R144	J707385P222	RES MFILM 2K2 5% 1/8W	1
R145	J707385P682	RES MFILM 6K8 5% 1/8W	1
R146	J707385P273	RES MFILM 27K 5% 1/8W	1
R147	J707385P104	RES MFILM 100K 5% 1/8W	1
R148	J707385P123	RES MFILM 12K 5% 1/8W	1
R149	J707385P472	RES MFILM 4K7 5% 1/8W	1
R150	J707385P102	RES MFILM 1K0 5% 1/8W	1
R151	J707385P683	RES MFILM 68K 5% 1/8W	1
R152	J707385P104	RES MFILM 100K 5% 1/8W	1
R153	J707385P472	RES MFILM 4K7 5% 1/8W	1
R154	J707385P274	RES MFILM 270K 5% 1/8W	1
R155	J707385P682	RES MFILM 6K8 5% 1/8W	1
R156	J707385P102	RES MFILM 1K0 5% 1/8W	1
R157	J707385P100	RES MFILM 10R 5% 1/8W	1
R158	J707385P102	RES MFILM 1K0 5% 1/8W	1
R159	J707385P472	RES MFILM 4K7 5% 1/8W	1
R201	J707385P561	RES MFILM 560R 5% 1/8W	1
R202	J707385P271	RES MFILM 270R 5% 1/8W	1
R203	J707385P153	RES MFILM 15K 5% 1/8W	1
R204	J707385P153	RES MFILM 15K 5% 1/8W	1
R205	J707385P472	RES MFILM 4K7 5% 1/8W	1
R206	J707385P272	RES MFILM 2K7 5% 1/8W	1

Pos.	Code No.	Description	Qt.
R207	J707385P563	RES MFILM 56K 5% 1/8W	1
R208	J707385P563	RES MFILM 56K 5% 1/8W	1
R209	J707385P271	RES MFILM 270R 5% 1/8W	1
R210	J707385P331	RES MFILM 330R 5% 1/8W	1
R301	J707385P331	RES MFILM 330R 5% 1/8W	1
R302	J707385P392	RES MFILM 3K9 5% 1/8W	1
R303	J707385P104	RES MFILM 100K 5% 1/8W	1
R304	J707385P104	RES MFILM 100K 5% 1/8W	1
R306	J707385P272	RES MFILM 2K7 5% 1/8W	1
R307	J707385P681	RES MFILM 680R 5% 1/8W	1
R308	J707385P470	RES MFILM 47R 5% 1/8W	1
R309	J707385P270	RES MFILM 27R 5% 1/8W	1
R310	J707385P104	RES MFILM 100K 5% 1/8W	1
R311	J707385P101	RES MFILM 100R 5% 1/8W	1
R312	J707385P104	RES MFILM 100K 5% 1/8W	1
R313	J707385P123	RES MFILM 12K 5% 1/8W	1
R314	J707385P104	RES MFILM 100K 5% 1/8W	1
R315	J707385P822	RES MFILM 8K2 5% 1/8W	1
R316	J707385P104	RES MFILM 100K 5% 1/8W	1
R317	J707385P471	RES MFILM 470R 5% 1/8W	1
R318	J707385P100	RES MFILM 10R 5% 1/8W	1
R319	J707385P101	RES MFILM 100R 5% 1/8W	1
R320	J707385P222	RES MFILM 2K2 5% 1/8W	1
R321	J707385P270	RES MFILM 27R 5% 1/8W	1
R322	J707385P471	RES MFILM 470R 5% 1/8W	1
R323	J707385P104	RES MFILM 100K 5% 1/8W	1
R324	J707385P104	RES MFILM 100K 5% 1/8W	1
R325	J707385P100	RES MFILM 10R 5% 1/8W	1
R327	J707385P123	RES MFILM 12K 5% 1/8W	1
R328	J707385P332	RES MFILM 3K3 5% 1/8W	1
R329	J707385P102	RES MFILM 1K0 5% 1/8W	1
R401	J707385P390	RES MFILM 39R 5% 1/8W	1
R402	J707385P100	RES MFILM 10R 5% 1/8W	1
R403	J707385P222	RES MFILM 2K2 5% 1/8W	1
R404	J707385P472	RES MFILM 4K7 5% 1/8W	1
R405	J707385P100	RES MFILM 10R 5% 1/8W	1

Pos.	Code No.	Description	Qt.
R406	J707385P820	RES MFILM 82R 5% 1/8W	1
R407	J707385P470	RES MFILM 47R 5% 1/8W	1
R408	J707385P470	RES MFILM 47R 5% 1/8W	1
R409	J707385P332	RES MFILM 3K3 5% 1/8W	1
R410	J707385P471	RES MFILM 470R 5% 1/8W	1
R411	J707385P123	RES MFILM 12K 5% 1/8W	1
R412	J707385P472	RES MFILM 4K7 5% 1/8W	1
R413	J707385P821	RES MFILM 820R 5% 1/8W	1
R414	J707385P332	RES MFILM 3K3 5% 1/8W	1
R415	J707385P222	RES MFILM 2K2 5% 1/8W	1
R416	J707385P562	RES MFILM 5K6 5% 1/8W	1
R417	J707385P103	RES MFILM 10K 5% 1/8W	1
R418	J707385P153	RES MFILM 15K 5% 1/8W	1
R419	J707385P182	RES MFILM 1K8 5% 1/8W	1
R420	J707385P182	RES MFILM 1K8 5% 1/8W	1
R421	J707385P182	RES MFILM 1K8 5% 1/8W	1
R422	J707385P473	RES MFILM 47K 5% 1/8W	1
R423	J707385P153	RES MFILM 15K 5% 1/8W	1
R424	J708538P5	RES VAR CER 10K 20% 0,5W	1
R425	J707385P272	RES MFILM 2K7 5% 1/8W	1
R426	J707385P563	RES MFILM 56K 5% 1/8W	1
R427	J707385P273	RES MFILM 27K 5% 1/8W	1
R428	J707385P683	RES MFILM 68K 5% 1/8W	1
R429	J707385P104	RES MFILM 100K 5% 1/8W	1
R430	J707385P334	RES MFILM 330K 5% 1/8W	1
R431	J707385P473	RES MFILM 47K 5% 1/8W	1
R432	J707385P473	RES MFILM 47K 5% 1/8W	1
R433	J707385P271	RES MFILM 270R 5% 1/8W	1
R434	J707385P102	RES MFILM 1K0 5% 1/8W	1
R435	J706147P3	RES THERM PTC 250R 25%	1
R436	J707385P392	RES MFILM 3K9 5% 1/8W	1
R437	J707406P7	RES THERM NTC 220R 10%	1
R438	J707385P222	RES MFILM 2K2 5% 1/8W	1
R439	J707385P392	RES MFILM 3K9 5% 1/8W	1
R440	J707385P392	RES MFILM 3K9 5% 1/8W	1
R441	J707385P101	RES MFILM 100R 5% 1/8W	1

Pos.	Code No.	Description	Qt.
R442	J708538P6	RES VAR CER 20K 20% 0,5W	1
R444	J707385P473	RES MFILM 47K 5% 1/8W	1
R445	J707385P273	RES MFILM 27K 5% 1/8W	1
R446	J707385P224	RES MFILM 220K 5% 1/8W	1
R447	J707385P392	RES MFILM 3K9 5% 1/8W	1
R448	J707385P101	RES MFILM 100R 5% 1/8W	1
R449	J707385P470	RES MFILM 47R 5% 1/8W	1
R450	J707385P103	RES MFILM 10K 5% 1/8W	1
R501	J707385P821	RES MFILM 820R 5% 1/8W	1
R502	J707385P821	RES MFILM 820R 5% 1/8W	1
R504	J707385P104	RES MFILM 100K 5% 1/8W	1
R505	J707385P104	RES MFILM 100K 5% 1/8W	1
R508	J707385P103	RES MFILM 10K 5% 1/8W	1
R509	J707385P151	RES MFILM 150R 5% 1/8W	1
R510	J707385P103	RES MFILM 10K 5% 1/8W	1
R512	J707385P561	RES MFILM 560R 5% 1/8W	1
R513	J707385P272	RES MFILM 2K7 5% 1/8W	1
R514	J707385P682	RES MFILM 6K8 5% 1/8W	1
R515	J707385P221	RES MFILM 220R 5% 1/8W	1
R516	J707385P221	RES MFILM 220R 5% 1/8W	1
R517	J707385P101	RES MFILM 100R 5% 1/8W	1
R518	J707385P100	RES MFILM 10R 5% 1/8W	1
R529	J707385P392	RES MFILM 3K9 5% 1/8W	1
R602	J707385P122	RES MFILM 1K2 5% 1/8W	1
R603	J707385P122	RES MFILM 1K2 5% 1/8W	1
R605	J707385P104	RES MFILM 100K 5% 1/8W	1
R606	J707385P104	RES MFILM 100K 5% 1/8W	1
R607	J707385P561	RES MFILM 560R 5% 1/8W	1
R608	J707385P682	RES MFILM 6K8 5% 1/8W	1
R610	J707385P331	RES MFILM 330R 5% 1/8W	1
R611	J707385P151	RES MFILM 150R 5% 1/8W	1
R612	J707385P102	RES MFILM 1K0 5% 1/8W	1
R613	J707385P101	RES MFILM 100R 5% 1/8W	1
R614	J707385P272	RES MFILM 2K7 5% 1/8W	1
R615	J707385P682	RES MFILM 6K8 5% 1/8W	1
R616	J707385P181	RES MFILM 180R 5% 1/8W	1

Pos.	Code No.	Description	Qt.
R617	J707385P563	RES MFILM 56K 5% 1/8W	1
R618	J707385P683	RES MFILM 68K 5% 1/8W	1
R619	J707385P104	RES MFILM 100K 5% 1/8W	1
R620	J707385P102	RES MFILM 1K0 5% 1/8W	1
R621	J707385P471	RES MFILM 470R 5% 1/8W	1
R622	J707385P151	RES MFILM 150R 5% 1/8W	1
R623	J707385P224	RES MFILM 220K 5% 1/8W	1
R624	J707385P223	RES MFILM 22K 5% 1/8W	1
R625	J707385P101	RES MFILM 100R 5% 1/8W	1
R626	J707385P100	RES MFILM 10R 5% 1/8W	1
R627	J707385P103	RES MFILM 10K 5% 1/8W	1
R628	J707385P224	RES MFILM 220K 5% 1/8W	1
R629	J707385P124	RES MFILM 120K 5% 1/8W	1
R630	J707385P100	RES MFILM 10R 5% 1/8W	1
R631	J707385P684	RES MFILM 680K 5% 1/8W	1
R632	J707385P223	RES MFILM 22K 5% 1/8W	1
R633	J707385P824	RES MFILM 820K 5% 1/8W	1
R634	J707385P123	RES MFILM 12K 5% 1/8W	1
R635	J707385P102	RES MFILM 1K0 5% 1/8W	1
R636	J707385P332	RES MFILM 3K3 5% 1/8W	1
R637	J707385P181	RES MFILM 180R 5% 1/8W	1
R638	J707385P474	RES MFILM 470K 5% 1/8W	1
R639	J707385P333	RES MFILM 33K 5% 1/8W	1
R640	J707385P105	RES MFILM 1M0 10% 1/8W	1
R641	J707385P184	RES MFILM 180K 5% 1/8W	1
R642	J707385P184	RES MFILM 180K 5% 1/8W	1
R643	J707385P105	RES MFILM 1M0 10% 1/8W	1
R644	J707385P473	RES MFILM 47K 5% 1/8W	1
R645	J707385P153	RES MFILM 15K 5% 1/8W	1
R646	J707385P393	RES MFILM 39K 5% 1/8W	1
R647	J707385P333	RES MFILM 33K 5% 1/8W	1
R649	J707385P473	RES MFILM 47K 5% 1/8W	1
R650	J707385P562	RES MFILM 5K6 5% 1/8W	1
R651	J707385P473	RES MFILM 47K 5% 1/8W	1
R652	J707385P223	RES MFILM 22K 5% 1/8W	1
R653	J707385P823	RES MFILM 82K 5% 1/8W	1

Pos.	Code No.	Description	Qt.
R654	J707385P153	RES MFILM 15K 5% 1/8W	1
R655	J707385P183	RES MFILM 18K 5% 1/8W	1
R656	J707385P393	RES MFILM 39K 5% 1/8W	1
R657	J707385P823	RES MFILM 82K 5% 1/8W	1
R658	J707385P154	RES MFILM 150K 5% 1/8W	1
R659	J707385P223	RES MFILM 22K 5% 1/8W	1
R660	J707385P333	RES MFILM 33K 5% 1/8W	1
R661	J707385P473	RES MFILM 47K 5% 1/8W	1
R662	J707385P473	RES MFILM 47K 5% 1/8W	1
R663	J708538P6	RES VAR CER 20K 20% 0,5W	1
R664	J707385P473	RES MFILM 47K 5% 1/8W	1
R665	J707385P824	RES MFILM 820K 5% 1/8W	1
R666	J707385P124	RES MFILM 120K 5% 1/8W	1
R667	J707385P124	RES MFILM 120K 5% 1/8W	1
R668	J707385P122	RES MFILM 1K2 5% 1/8W	1
R669	J707385P221	RES MFILM 220R 5% 1/8W	1
R670	J707385P103	RES MFILM 10K 5% 1/8W	1
R671	J707385P562	RES MFILM 5K6 5% 1/8W	1
R672	J707385P822	RES MFILM 8K2 5% 1/8W	1
R673	J707385P822	RES MFILM 8K2 5% 1/8W	1
R674	J707385P101	RES MFILM 100R 5% 1/8W	1
R675	J708538P5	RES VAR CER 10K 20% 0,5W	1
R676	J707385P562	RES MFILM 5K6 5% 1/8W	1
R677	J708538P5	RES VAR CER 10K 20% 0,5W	1
R678	J707385P470	RES MFILM 47R 5% 1/8W	1
R679	J707385P821	RES MFILM 820R 5% 1/8W	1
R680	J708538P6	RES VAR CER 20K 20% 0,5W	1
R681	J707385P223	RES MFILM 22K 5% 1/8W	1
R682	J707385P223	RES MFILM 22K 5% 1/8W	1
R683	J707385P223	RES MFILM 22K 5% 1/8W	1
R684	J707385P183	RES MFILM 18K 5% 1/8W	1
R685	J707385P183	RES MFILM 18K 5% 1/8W	1
R686	J707385P103	RES MFILM 10K 5% 1/8W	1
R687	J707385P103	RES MFILM 10K 5% 1/8W	1
R689	J707385P105	RES MFILM 1M0 10% 1/8W	1
R690	J707385P124	RES MFILM 120K 5% 1/8W	1

Pos.	Code No.	Description	Qt.
R691	J707385P273	RES MFILM 27K 5% 1/8W	1
R692	J707385P223	RES MFILM 22K 5% 1/8W	1
R693	J707385P105	RES MFILM 1M0 10% 1/8W	1
R694	J707385P223	RES MFILM 22K 5% 1/8W	1
R695	J707385P105	RES MFILM 1M0 10% 1/8W	1
R696	J707385P223	RES MFILM 22K 5% 1/8W	1
R697	J707385P105	RES MFILM 1M0 10% 1/8W	1
R698	J707385P272	RES MFILM 2K7 5% 1/8W	1
R699	J707385P392	RES MFILM 3K9 5% 1/8W	1
R702	A701250P413	RES MFILM 133K 1% 1/4W	1
R703	A701250P213	RES MFILM 1K33 1% 1/4W	1
R704	A701250P326	RES MFILM 18K2 1% 1/4W	1
R707	J707385P104	RES MFILM 100K 5% 1/8W	1
R708	J707385P105	RES MFILM 1M0 10% 1/8W	1
R709	J707385P181	RES MFILM 180R 5% 1/8W	1
R710	J707385P101	RES MFILM 100R 5% 1/8W	1
R711	J707385P223	RES MFILM 22K 5% 1/8W	1
R712	J707385P154	RES MFILM 150K 5% 1/8W	1
R713	J707385P821	RES MFILM 820R 5% 1/8W	1
R714	J707385P104	RES MFILM 100K 5% 1/8W	1
R715	J707385P563	RES MFILM 56K 5% 1/8W	1
U100	J708165P2	IC LIN OP-AMP 324	1
U201	J708333P1	IC LIN VR FIX 4785	1
U401	J707449P1	IC LIN IF-AMP 3357	1
U402	M905766G2	INT CKT SQ 4003	1
U402	M905766G1	INT CKT SQ 4002	1
U601	J708165P4	IC LIN OP-AMP 358	1
U602	J708165P4	IC LIN OP-AMP 358	1
U604	J708165P4	IC LIN OP-AMP 358	1
U606	J707243P1	IC DIG REG 4094 CMOS	1
U607	J707374P1	IC PLL PRESC ECL 8793	1
U608	B800902P1	IC CMOS SYNTHESIZER	1
U609	J708165P4	IC LIN OP-AMP 358	1
U610	J708503P2	IC LIN CMPAR LM 339	1
U615	J708621P2	CPLR OPTO PC 827	1
U616	J708503P2	IC LIN CMPAR LM 339	1

**G4/G6 ONLY
G5 ONLY**

Storno

Storno

Pos.	Code No.	Description	Qt.
W003	J707256P1	COIL FIX	1
W004	J707256P1	COIL FIX	1
W005	J708717P1	STRAP	1
Y401	J707309P1	X-TAL 20,945MHZ	1
Y701	J708424P4	CRYSTAL UNIT 7.3978MHZ	1
Z401	J707310P1	FLT 21,4MHZ	1
Z401	J707310P2	FLT 21,4MHZ	1
Z401	J707310P3	FLT 21,4MHZ	1
Z402	J707446P1	FLT 455KHZ	1
Z402	J707446P3	FLT 455KHZ	1
Z402	J707446P4	FLT 455KHZ	1
Z403	J707446P1	FLT 455KHZ	1
Z403	J707446P3	FLT 455KHZ	1
Z403	J707446P4	FLT 455KHZ	1
0002	M905893P1R0	BD PW	1
0010	J707256P4	COIL FIX	3
0011	K805776P1	CASTING HEAT SINK	1
0012	K805569G2	SHIELD METALLIZED	1
0013	J706281P7	CORE	8

Pos.	Code No.	Description	Qt.

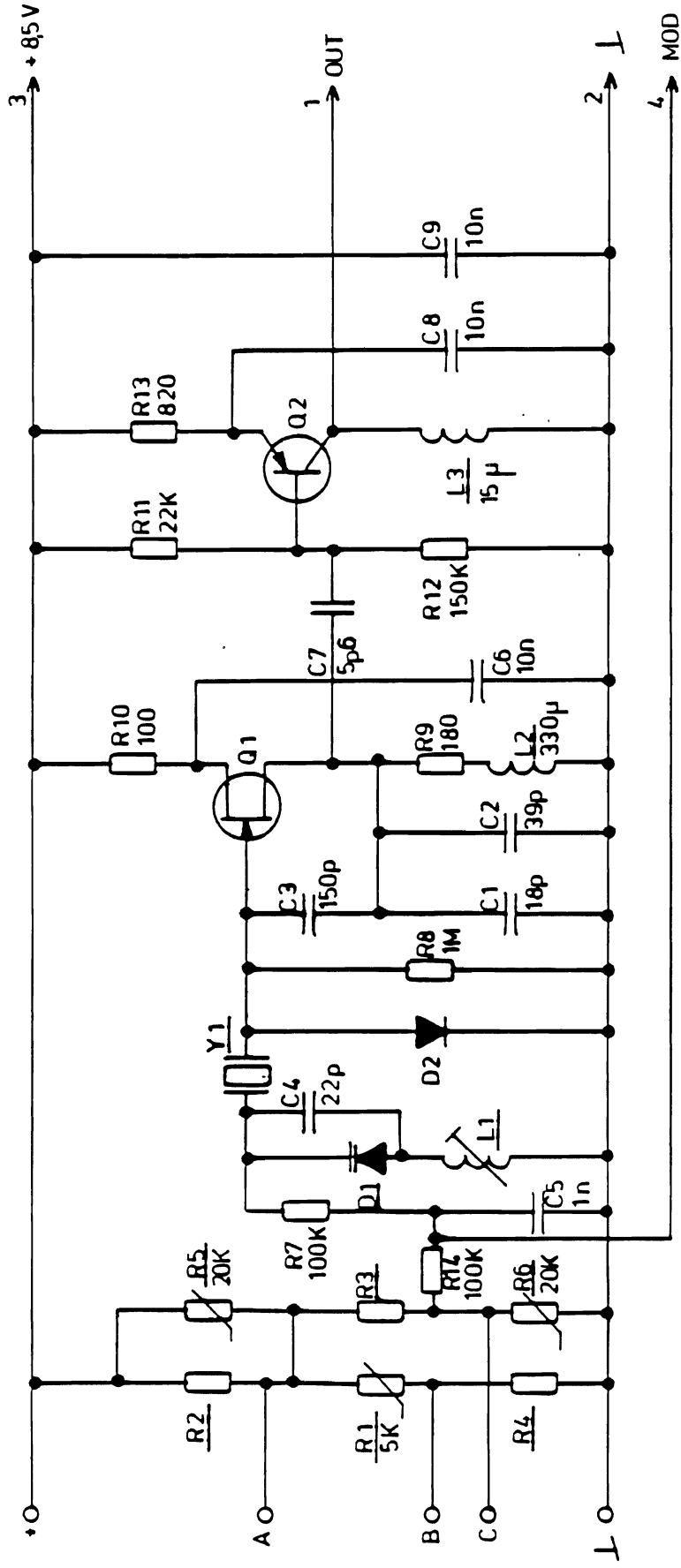

* R2,R3 AND R4 ARE FACTORY SELECTED COMPONENTS .

COMPONENTS MARKED RXXX ARE
PLACED ON COMPONENT SIDE

19L 855597	R 2	R 3	R4
G1 *	19A701250P125 TO	19A701250P125 TO	19A701250P125 TO
G2	19A701250P441 5 PPM	19A701250P441 5 PPM	19A701250P441 5 PPM

CHIP SIDE

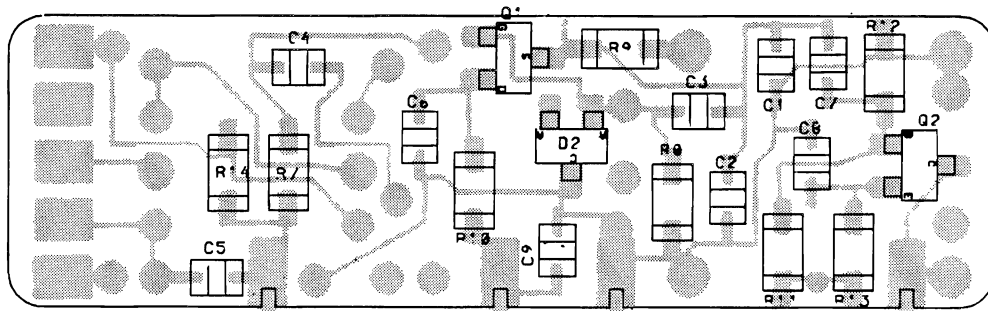

COMPONENT SIDE

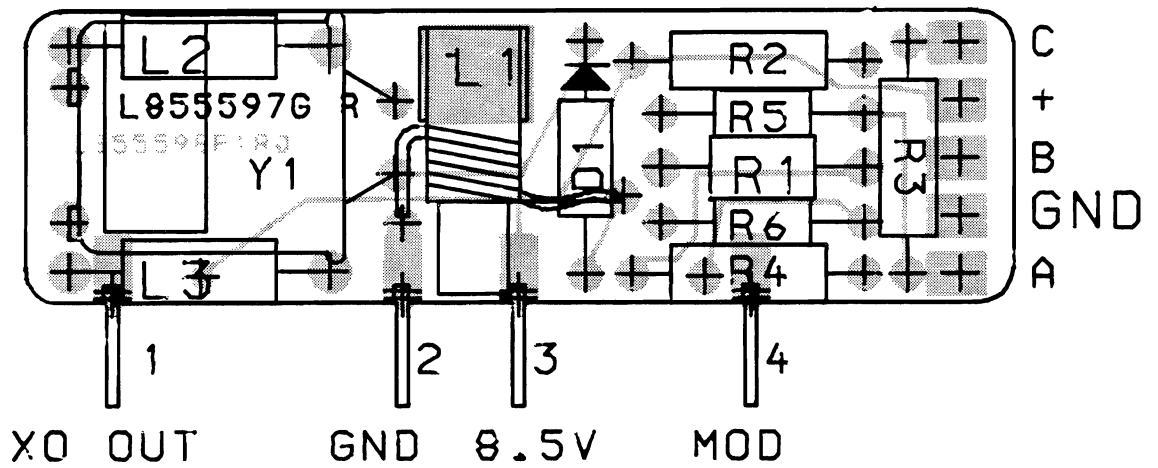

CRYSTAL OSCILLATOR XO6000
COMPONENT LAYOUT

D404.226

CF6001

COMMON FUNCTION BOARD

POWER SUPPLY

The power supply is of a switched mode design in order to generate the required voltages at a reasonable efficiency. The power supply comprises input filter, chopper stage, filter, voltage protect and regulator.

The battery supply passes through an input filter consisting of L701, C701 and C702. This attenuates the noise generated by the chopper stage and prevents unwanted sidebands on the transmitted signal and improves the supply ripple injection.

The chopper stage consists of two transistors operated in parallel (Q701, Q702), so keeping the individual device dissipation below the level requiring the use of a heatsink.

The chopped supply is filtered by L702, C706, C707 to provide the +5 Volt supply. Regulation is achieved by adjusting the mark-to-space ratio of the chopper drive signal, this being derived by comparing the +5 Volt supply with a 4.7 Volt Zener diode reference (D704). The 5 Volt supply can be adjusted by R709.

Overcurrent and overvoltage protection are also incorporated, the latter using a 'crow-bar' protection thyristor D705.

The two minus supplies are derived from the secondary winding on L702. The -5 Volt supply does not require tight regulation but the -24 Volt supply must be accurately set and is therefore made variable by R719. The noise level on the -24 Volt supply is critical and so extra filtering (L703) is included.

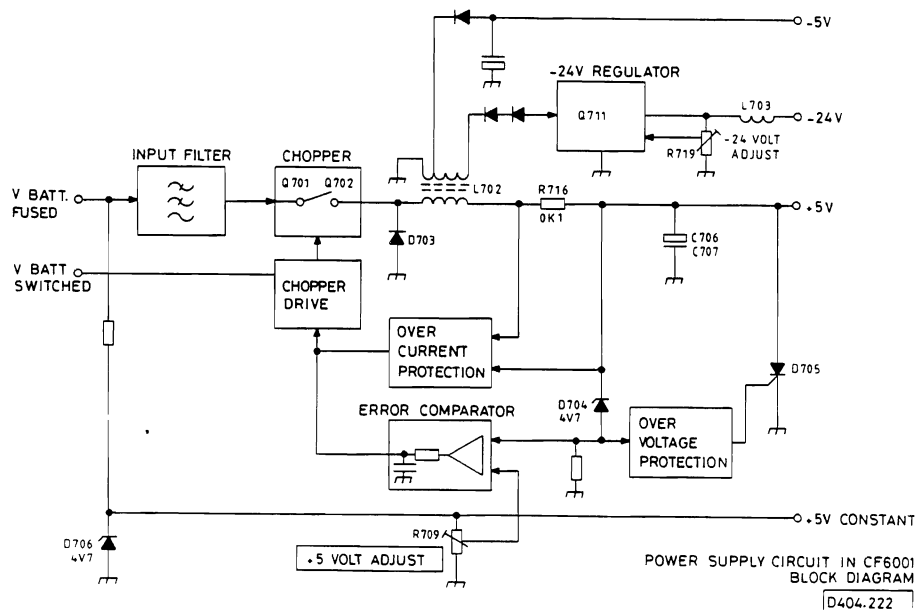

LOGIC CIRCUITS

MAIN CONTROLLER

The main controller includes the main processor with its associated memories, etc.

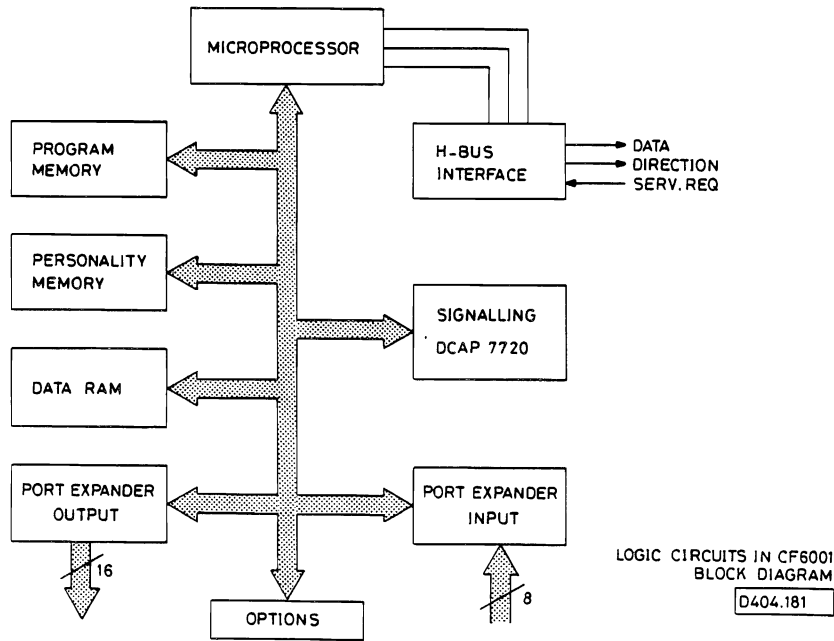

The various functions such as volume control, audio path switching, watchdog control etc. are controlled by the main processor via or expanders operating directly on the micro data bus. There are 16 expander output pins grouped into 4 sets of 4 (U803, U811, U801, U910). These locations are written to, and read from like normal RAM locations.

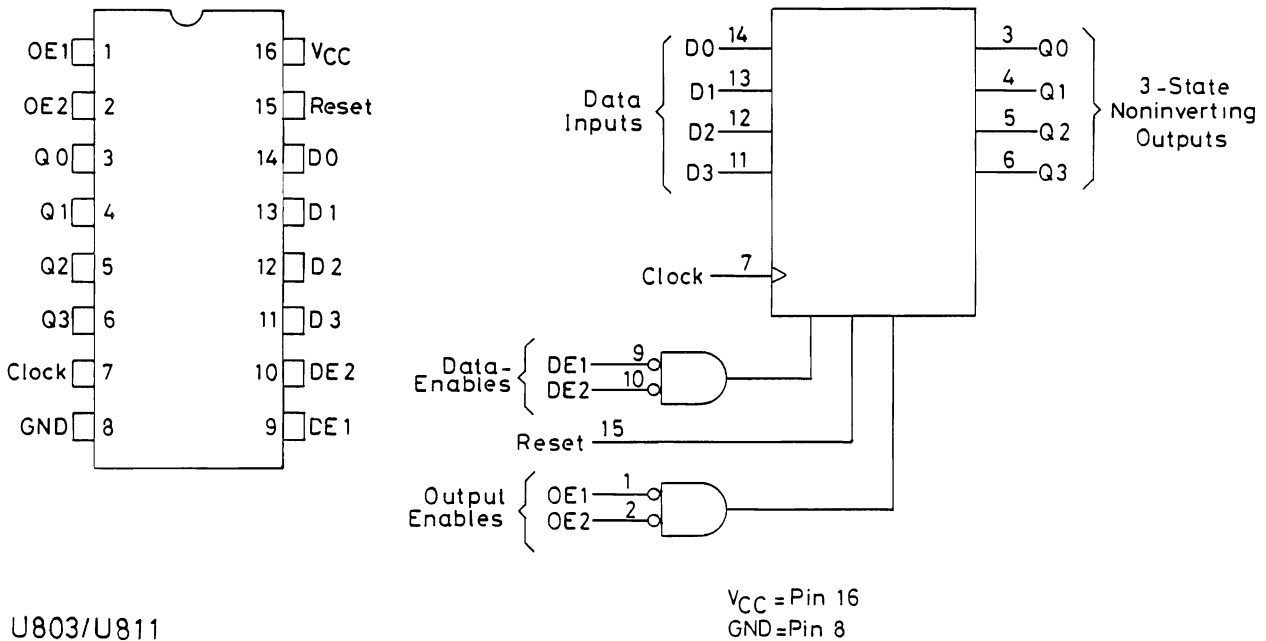

U803/U811

MICROPROCESSOR 8031, U906

The processor used in the CF6001 is a single-component 8-bit microprocessor 8031. The microprocessor contains a volatile 128 x 8 read/write data memory; 32 I/O lines; two 16-bit timer/event counters; a five-source, two-priority-level nested, interrupt structure; serial I/O port for either multiprocessor communications, I/O expansion, or full duplex UART; and on-chip oscillator and clock circuits.

The microprocessor is operated at a clock frequency of 11.132 MHz from the crystal Y901 giving a machine cycle time of approximately 1 usec.

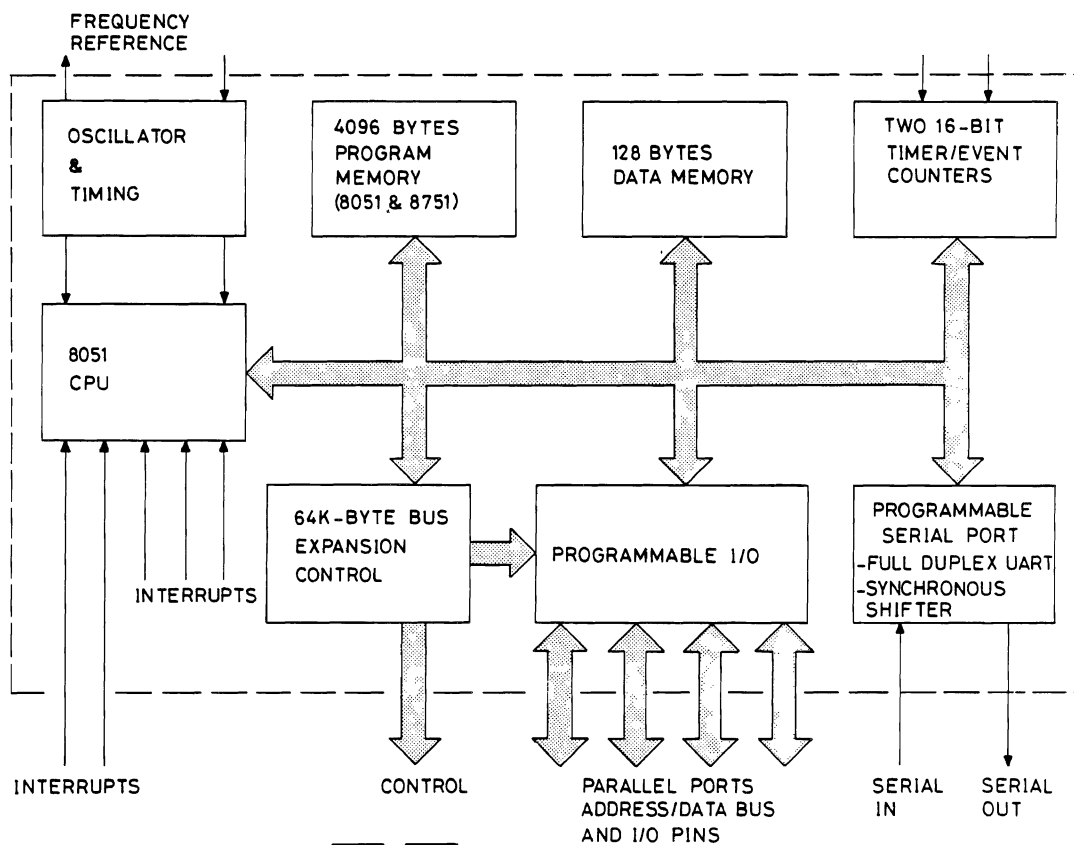

P1.0	1	40	VCC
P1.1	2	39	P0.0 AD 0
P1.2	3	38	P0.1 AD 1
P1.3	4	37	P0.2 AD 2
P1.4	5	36	P0.3 AD 3
P1.5	6	35	P0.4 AD 4
P1.6	7	34	P0.5 AD 5
P1.7	8	33	P0.6 AD 6
RST/VPD	9	32	P0.7 AD 7
RXD P3.0	10	31	\overline{EA}/VDD
TXD P3.1	11	30	ALE PROG
INT 0 P3.2	12	29	\overline{PSEN}
INT 1 P3.3	13	28	P2.7 A15
T 0 P3.4	14	27	P2.6 A14
T 1 P3.5	15	26	P2.5 A13
\overline{VR} P3.6	16	25	P2.4 A12
\overline{RD} P3.7	17	24	P2.3 A11
XTAL 1	18	23	P2.2 A10
XTAL 2	19	22	P2.1 A9
VSS	20	21	P2.0 A8

MICROPROCESSOR 8031/8051/8751
BLOCK DIAGRAM
D404.031/2

Pin Description V_{SS}

Circuit ground potential.

 V_{CC}

+5V power supply during operation, programming and verification.

PORT 0

Port 0 is an 8-bit open drain bidirectional I/O port. It is also the multiplexed low-order address and data bus when using external memory. It is used for data input and output during programming and verification.

Port 0 can sink/source two TTL loads.

PORT 1

Port 1 is an 8-bit quasi-bidirectional I/O port. It is used for the low-order address byte during programming and verification. Port 1 can sink/source one TTL load.

PORT 2

Port 2 is an 8-bit quasi-bidirectional I/O port. It also emits the high-order address byte when accessing external memory. It is used for the high-order address and the control signals during programming and verification. Port 2 can sink/source one TTL load.

PORT 3

Port 3 is an 8-bit quasi-bidirectional I/O port. It also contains the interrupt, timer, serial port and \overline{RD} and \overline{WR} pins that are used by various options. The output latch corresponding to a secondary function must be programmed to a one (1) for that function to operate. Port 3 can sink/ source one TTL load. The secondary functions are assigned to the pins of Port 3, as follows:

- RXD/data (P3.0). Serial port's receiver data input (asynchronous) or data input/output (synchronous).
- TXD/clock (P3.1). Serial port's transmitter data output (asynchronous) or clock output (synchronous).
- $\overline{INT0}$ (P3.2). Interrupt 0 input or gate control input for counter 0.
- $\overline{INT1}$ (P3.3). Interrupt 1 input or gate control input for counter 1.
- T0 (P3.4). Input to counter 0.
- T1 (P3.5). Input to counter 1.
- \overline{WR} (P3.6). The write control signal latches the data byte from Port 0 into the External Data Memory.
- \overline{RD} (P3.7). The read control signal enables External Data Memory to Port 0.

RST/ V_{PD}

A low to high transition on this pin (at approximately 3 V) resets the microprocessor. If V_{PD} is held within its spec (approximately +5 V), while V_{CC} drops below spec, V_{PD} will provide standby power to the RAM. When V_{PD} is low, the RAM's current is drawn from V_{CC} . A small internal resistor permits power-on reset using only a capacitor connected to V_{CC} .

ALE/PROG

Provides Address Latch Enable output used for latching the address into external memory during normal operation. Receives the program pulse input during EPROM programming.

PSEN

The Program Store Enable output is a control signal that enables the external Program Memory to the bus during normal fetch operations.

EA/VDD

When held at a TTL high level, the processor executes instructions from the internal ROM/ EPROM when the PC is less than 4096. When held at a TTL low level, the processor fetches all instructions from external Program Memory.

The pin also receives the 21 V EPROM programming supply voltage.

XTAL1

Input to the oscillator's high gain amplifier. A crystal or external source can be used.

XTAL2

Output from the oscillator's amplifier. Required when a crystal is used.

ADDRESS LATCH, U903

U903 is an Address Latch. The latch appears transparent to data (i.e., the outputs change asynchronously) when Latch Enable is high. When Latch Enable goes low, data meeting the set-up time become latched.

The Output Enable input does not affect the state of the latches, but when Output Enable is high, all outputs are forced to the high-impedance state. Data may thus be latched even when the device is not selected.

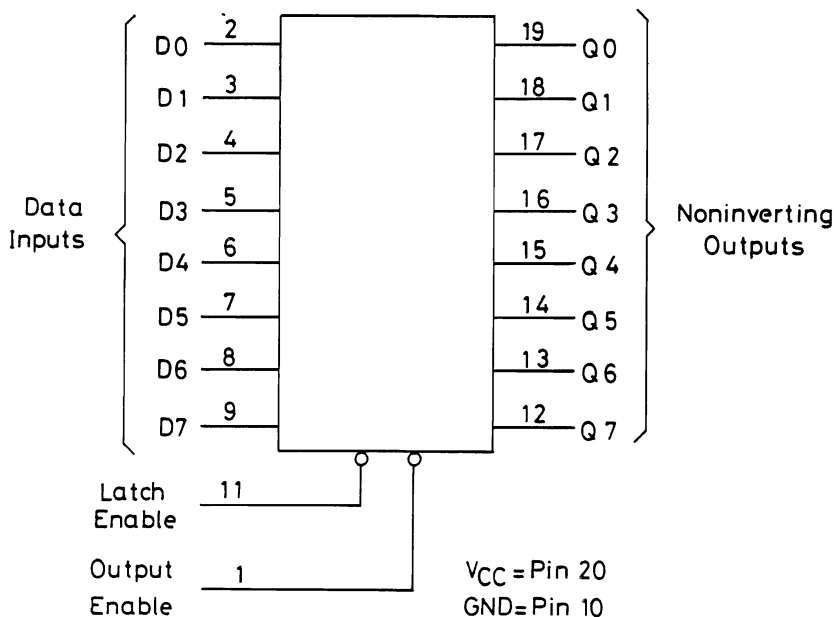

Inputs			Output
Output Enable	Latch Enable	D	Q
L	H	H	H
L	H	L	L
L	L	X	no change
H	X	X	Z

X= don't care
Z= high impedance

PINNING AND FUNCTION TABLE U903

RAM, U905

U905 is a 2K x 8-bit CMOS static Random Access Memory (RAM) with \overline{OE} for fast memory access and \overline{CE} for minimum stand-by current.

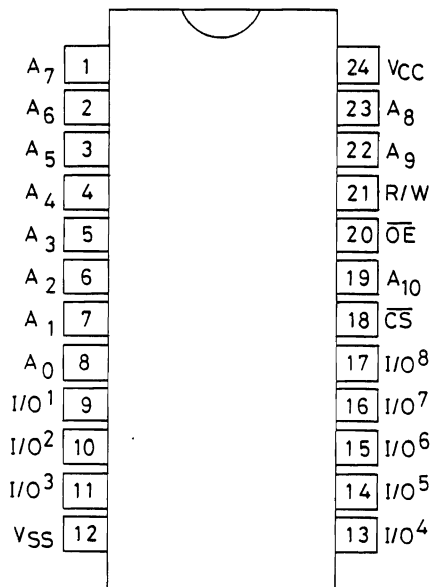
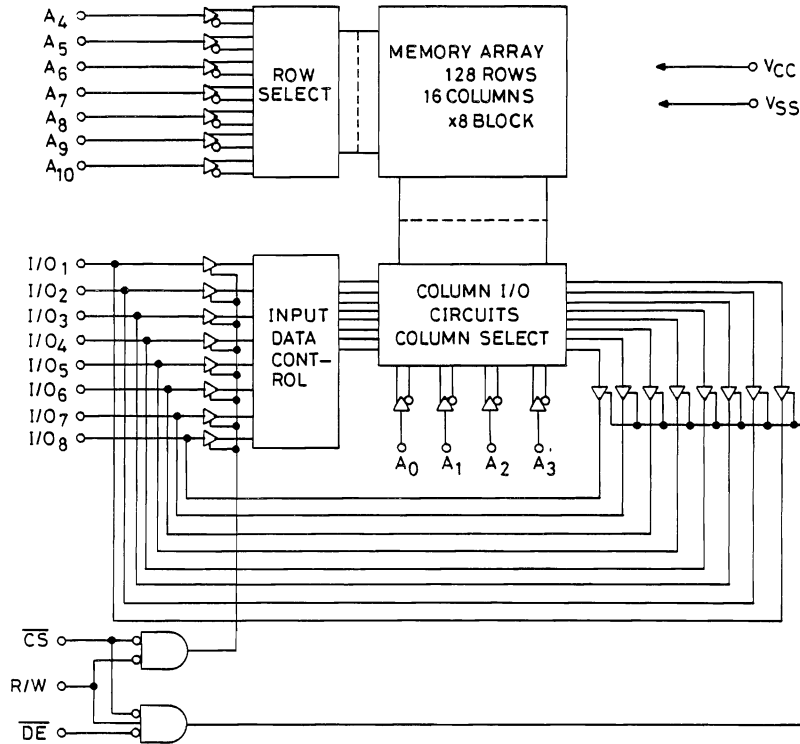

BLOCK DIAGRAM U905

The RAM is write protected when a power failure occurs. When the power is critical, a "high" (taken from +5 V cont.) will occur on u-reset (J90A+B, pin 21). This will result in a "high" (this "high" will follow the V_{CC} until the V_{CC} reaches 2 V) on U914A, pin 7, which disables the RAM. If V_{CC} is less than 4 V, Q903 will turn off and Q905 will turn on to prevent Q904 to turn on. R924 will then clamp CE on U906 to "high".

EEPROM, U904

U904 is a 5-volt 2048 x 8-bit Electrically Erasable Programmable Read Only Memory (EEPROM). High voltage programming is optional. The package is a dual-in-line.

When V_{CC} is below 3.0 V (V_{WI}), write-cycles to the device will automatically be inhibited. During power-up, the device automatically prevents any write operation for a period between 5 and 20 ms after V_{CC} reaches the V_{WI} level.

A \overline{WE} pulse of less than 20 ns will not initiate a write-cycle.

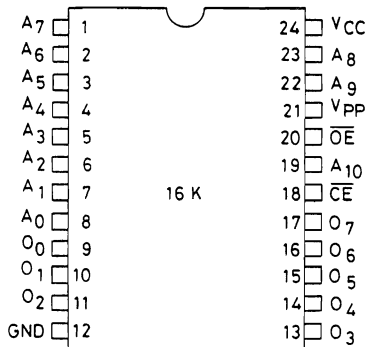
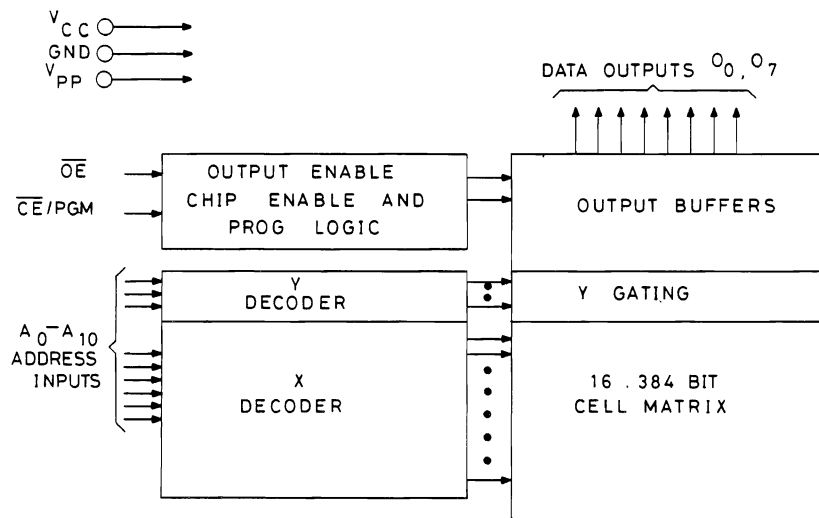

$A_0 - A_{10}$	ADDRESSES
\overline{CE}/PGM	CHIP ENABLE/PROGRAM
\overline{OE}	OUTPUT ENABLE
$O_0 - O_7$	OUTPUTS

BLOCK DIAGRAM U904

EPROM U902

U902 is a 32K x 8 bit Ultraviolet Erasable and Electrically Programmable Read-Only-Memories (EPROM), in a dual-in-line package. The EPROM contains the program as such of the radio. During Read operation the V_{CC} power supply must be $5\text{ V} \pm 5\%$ and the V_{PP} voltage must equal V_{CC} .

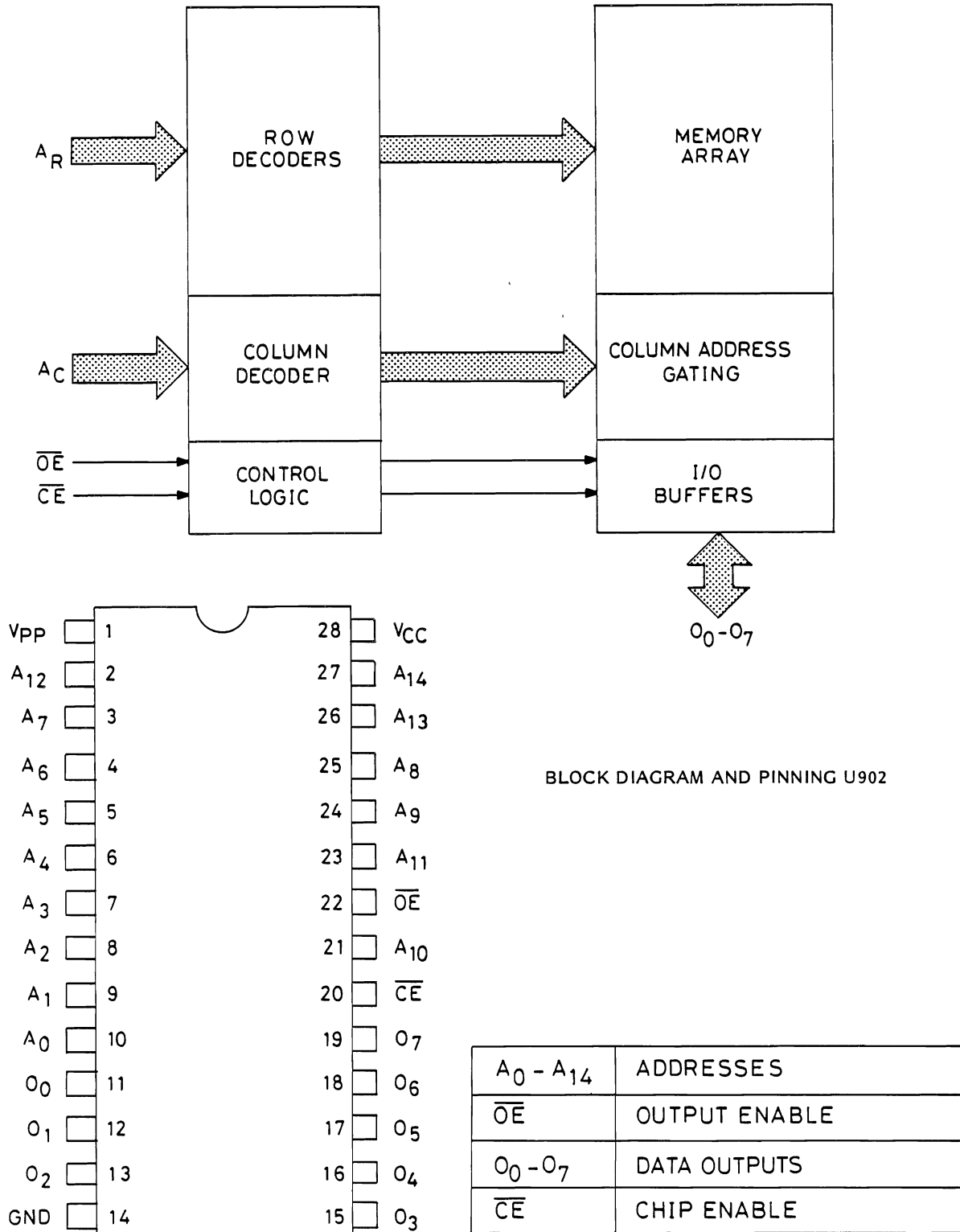

INPUT EXPANDER, U910

U910 is a tri-state octal D-type latch serving as an input expander.

OUTPUT EXPANDERS, U909 - U913

U909 - U913 are quad 3-state Dtype flip-flops serving as output expanders.

Data meeting the set-up time is clocked to the outputs with the rising edge of the clock. The "Output Enable" input does not affect the states of the flip-flops, but when Output Enable is high, the outputs are forced to the high-impedance state. Data may thus be stored even when the device is not selected.

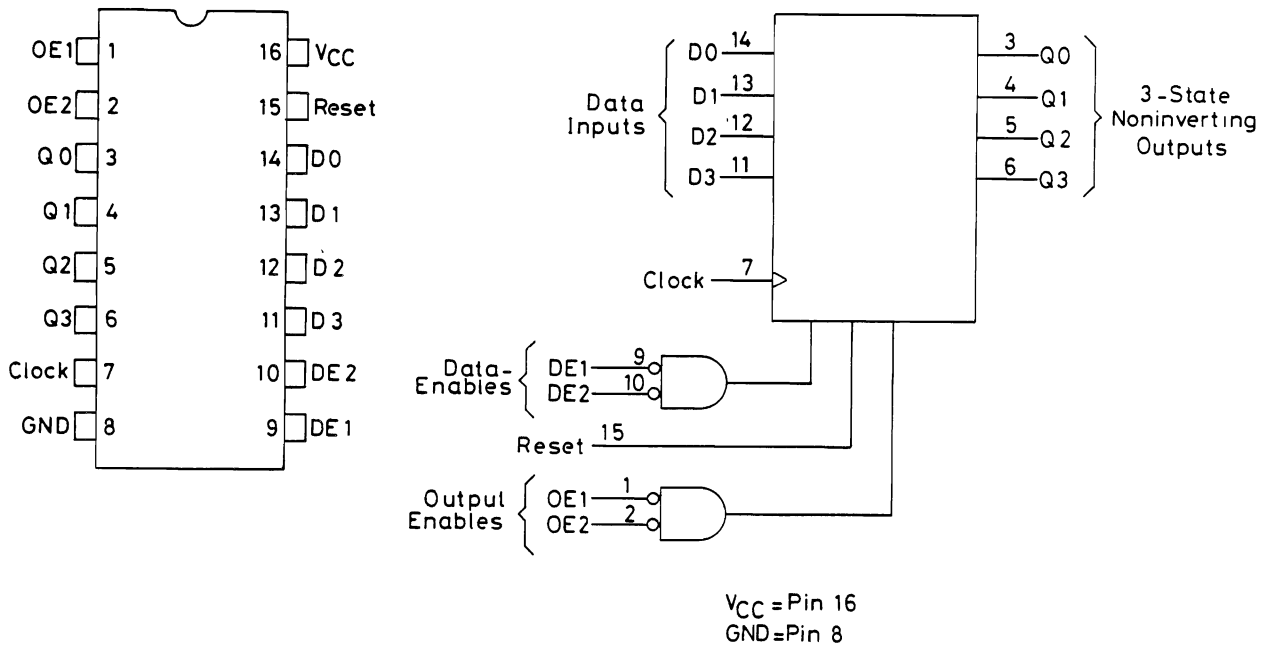

Output Enables		Inputs					Output Q
OE1	OE2	Reset	Clock	Data Enables		Data	
				DE1	DE2	D	
L	L	H	X	X	X	X	L
L	L	L	L	X	X	X	no change
L	L	L	H	X	X	X	no change
L	L	L		H	X	X	no change
L	L	L		X	H	X	no change
L	L	L		L	L	L	L
L	L	L		L	L	H	H
L	L	L		X	X	X	no change
L	H	X	X	X	X	X	high impedance
H	L	X	X	X	X	X	high impedance
H	H	X	X	X	X	X	high impedance

U909/U913 BLOCK DIAGRAM, PINNING AND TRUTH TABLE

U908 and U911 selects the code plug unit used as an option in the CQM6xxx.

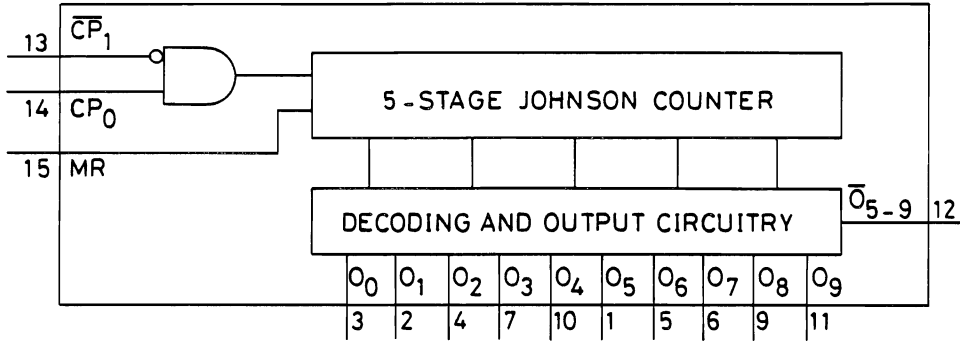

MR	CP ₀	CP ₁	Operation
H	X	X	O ₀ = O ₅₋₉ = H; O ₁ to O ₉ = L
L	H	↘	Counter advances
L	↗	L	Counter advances
L	L	X	No change
L	X	H	No change
L	H	↗	No change
L	↘	L	No change

PINNING

- CP₀ clock input (LOW to HIGH triggered)
- CP₁ clock input (HIGH to LOW triggered)
- MR master reset input
- O₀ to O₉ decoded outputs
- O₅₋₉ carry output (active LOW)

V_{SS} = pin 8
V_{DD} = pin 16

H= HIGH state (the more positive voltage)
L= LOW state (the less positive voltage)
X= don't care
↗= positive-going transition
↘= negative-going transition

U908, BLOCK DIAGRAM, PINNING AND TRUTH TABLE

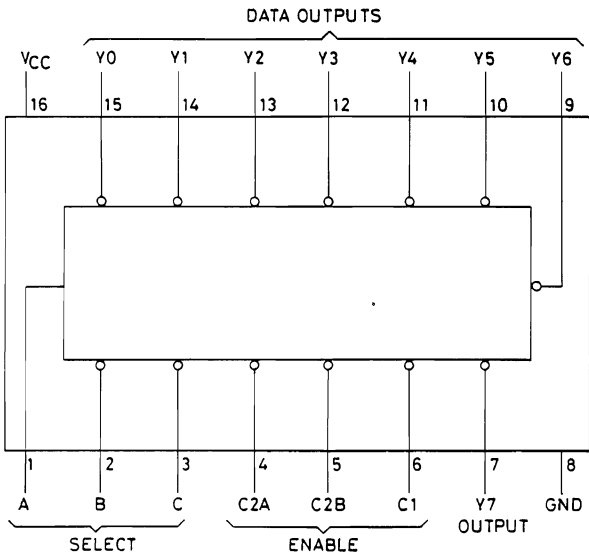

Inputs		Outputs										
Enable	Select											
G1	G2*	C	B	A	Y0	Y1	Y2	Y3	Y4	Y5	Y6	Y7
X	H	X	X	X	H	H	H	H	H	H	H	H
L	X	X	X	X	H	H	H	H	H	H	H	H
H	L	L	L	L	L	H	H	H	H	H	H	H
H	L	L	L	H	H	L	H	H	H	H	H	H
H	L	L	H	L	H	H	L	H	H	H	H	H
H	L	L	H	H	H	H	H	L	H	H	H	H
H	L	H	L	L	H	H	H	H	L	H	H	H
H	L	H	H	L	H	H	H	H	H	L	H	H
H	L	H	H	H	H	H	H	H	H	H	L	H

*G2 = G2A + G2B
H= high level
L= low level
X= don't care

U911, BLOCK DIAGRAM, PINNING AND TRUTH TABLE

3-STATE BUFFER U901

U901 which is the H-bus driver, is a Hex non-inverting buffer with 3-state outputs, and a high current source and sink capability.

H-BUS DATA SIGNALLING

The H-bus is a low-impedance bus with tri-state outputs.

The master controls the bus by controlling the DIRECTION-line (DIR). When the master activates DIR, this indicates to all the slaves, that the next byte on the DATA-line contains the address of the slave with which the master wants to communicate with. Every module on the bus must read this byte, and the one who recognizes its own address must activate its local output enable line and continue to collect all bytes arriving, untill the master complements DIR, and then it must transmit the appropriate response.

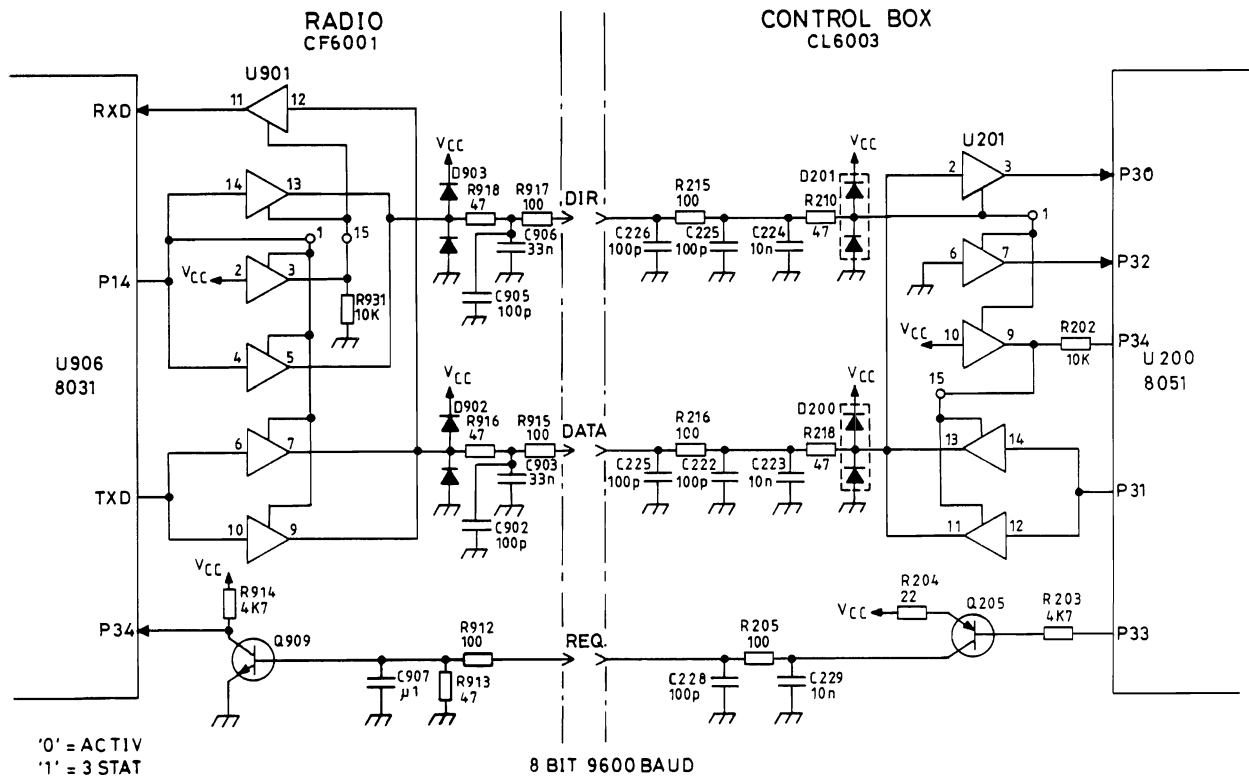

H-BUS DATA SIGNALLING BETWEEN CF6001 AND CL6003

D404.300

BYTE-FORMAT ON THE BUS



Each byte sent on the bus contains a start-bit (low), 8 data-bits (LSB first), a parity-bit (even) and a stop-bit (high).

The H-bus is operating at a speed of 9.625 baud, thus taking about 1.1 ms to transfer each byte.

ON/OFF RESET

Certain signalling requirements add complications to the operation of the on/off system in the radio.

For example, the system may require that the radio sends a signalling message before switching off. When the operator presses the on/off button the radio must send the message and then turn off the hardware. This means that the ultimate decision to turn off the radio is taken by the main processor, not by the operator.

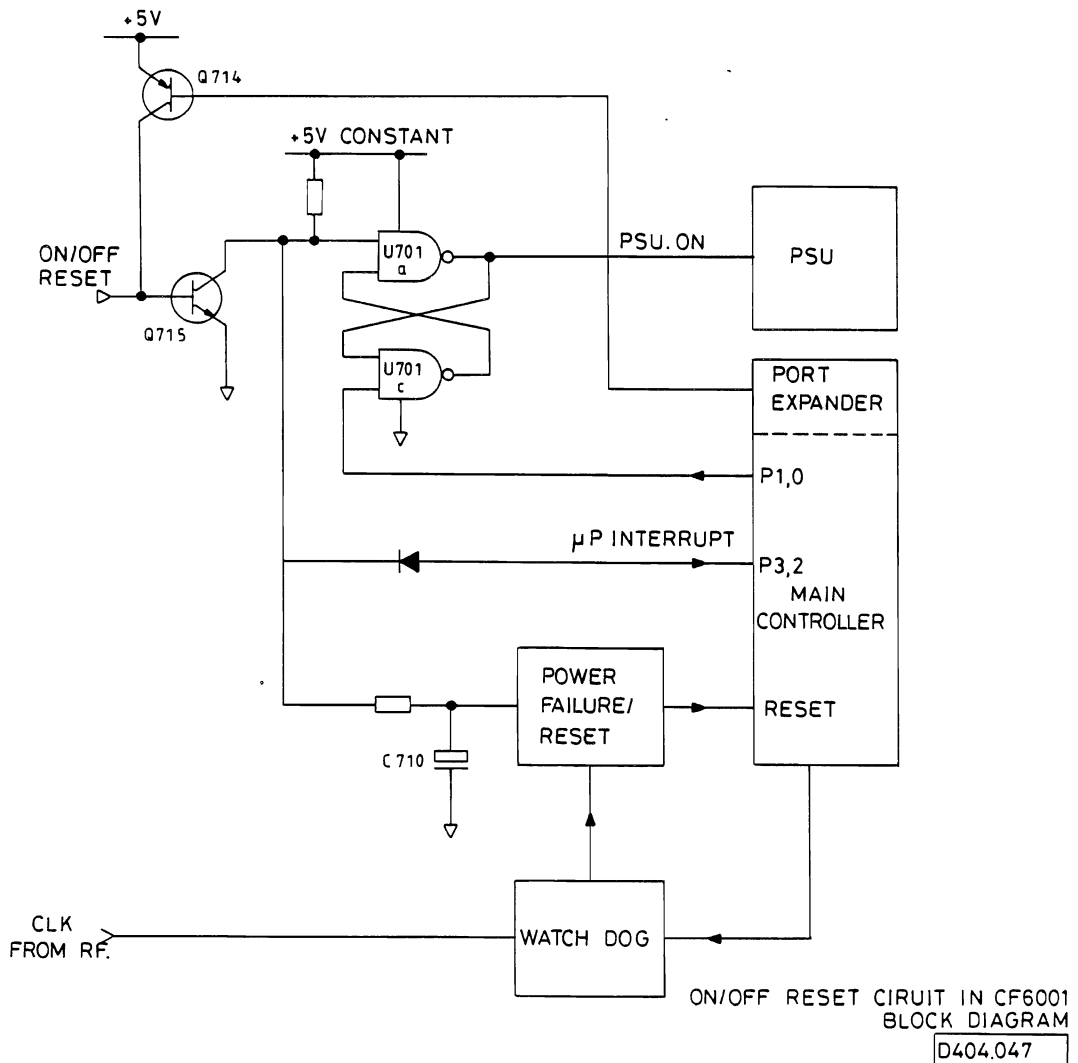

A watchdog consisting of U703, U704, U705 and associated components, is used for monitoring the correct operation of the main processor and for resetting the whole system, should it detect a fault. If this system should fail the operator can effect a total reset by keeping the ON/OFF button depressed for more than 3 seconds.

The on/off status of the radio is held in the flip-flop formed by U701a, U701c. This IC is supplied from the constant +5 volt supply and is active all the time during which the radio is connected to a suitable supply.

By pressing the ON/OFF button a positive potential is placed onto the ON/OFF RESET line, and Q715 will conduct and set the ON/OFF status flip-flop. The power supply will then turn on.

At this stage, with all supplies available, the main processor can function correctly, P1.0 on U906 will be taken high by the reset signal and will remain so until the microprocessor decides to turn off the board. By pressing the ON/OFF button again, the main controller will receive a high level interrupt (via D707), and will be able to decide whether or not to act on the ON/OFF request.

After performing the appropriate operations the microprocessor takes P1.0 low, resetting the ON/OFF status flip-flop and switching the power supply off.

The system may be reset from the control box by pressing the ON/OFF button for more than 3 seconds. This will discharge C710 and reset the main processor via the power failure circuitry.

In order to supply the necessary reset pulse to other devices external to the radio but operating on the same ON/OFF RESET line high to +5 volts by making Q714 conduct.

LOW VOLTAGE RESET, U702 c/d

Two comparators U702c, U702d monitor the battery and the +5 Volt supplies and provides signals to the main processor in the event of a power failure. At battery levels between 7 and 9 Volt the main processor receives an interrupt and proceeds to load important status information into the battery backed-up RAM. At Voltage levels below 7 Volt the main processor is reset and remains so until the battery supply rises above approx. 9 Volt.

AUDIO/SIGNALLING

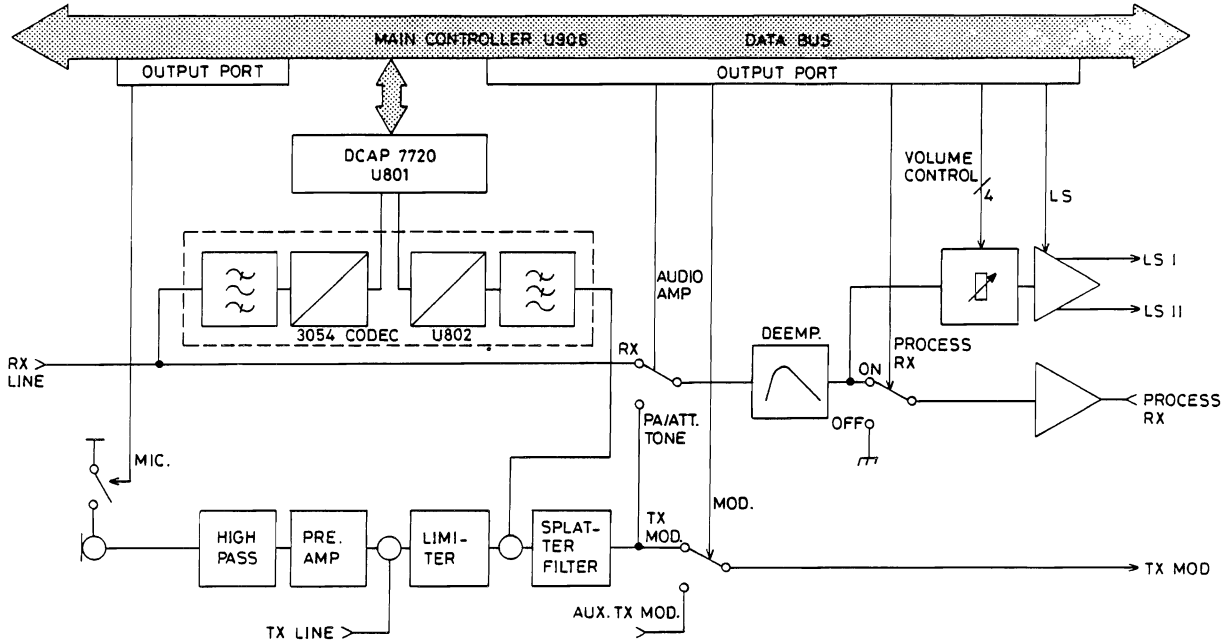

AUDIO SIGNALLING CIRCUITRY IN CF6001
BLOCK DIAGRAM
D404.297

DIGITAL SIGNAL PROCESSOR 7720, U801

The majority of the signalling functions are performed in U801 (7720). The 7720 is especially optimized for signal processing. It features a 16 bit wide ALU (Arithmetic/Logic Unit), a 16 x 16 parallel multiplier, 23 bit wide programme word and only 250 nsec. instruction cycle time.

The 7720 has two I/O ports, one of which is an eight bit parallel port, compatible with the main processor data bus, and the other being a serial I/O port for the transfer of the digitalised audio signal.

The realisation of a function actually corresponds to a call to a subroutine with the passing of the appropriate parameters. For example, the same basic filter routine may be made to work at different cut-off frequencies by sending different parameters to the routine.

Most of the parameters required by the different subroutines such as cut-off frequencies, oscillator frequencies and amplitudes can be set externally by the main controller.

The 7720 is setup for a given function by interrupting its present process and sending two eight bit command words via the parallel data bus to registers internal to the 7720.

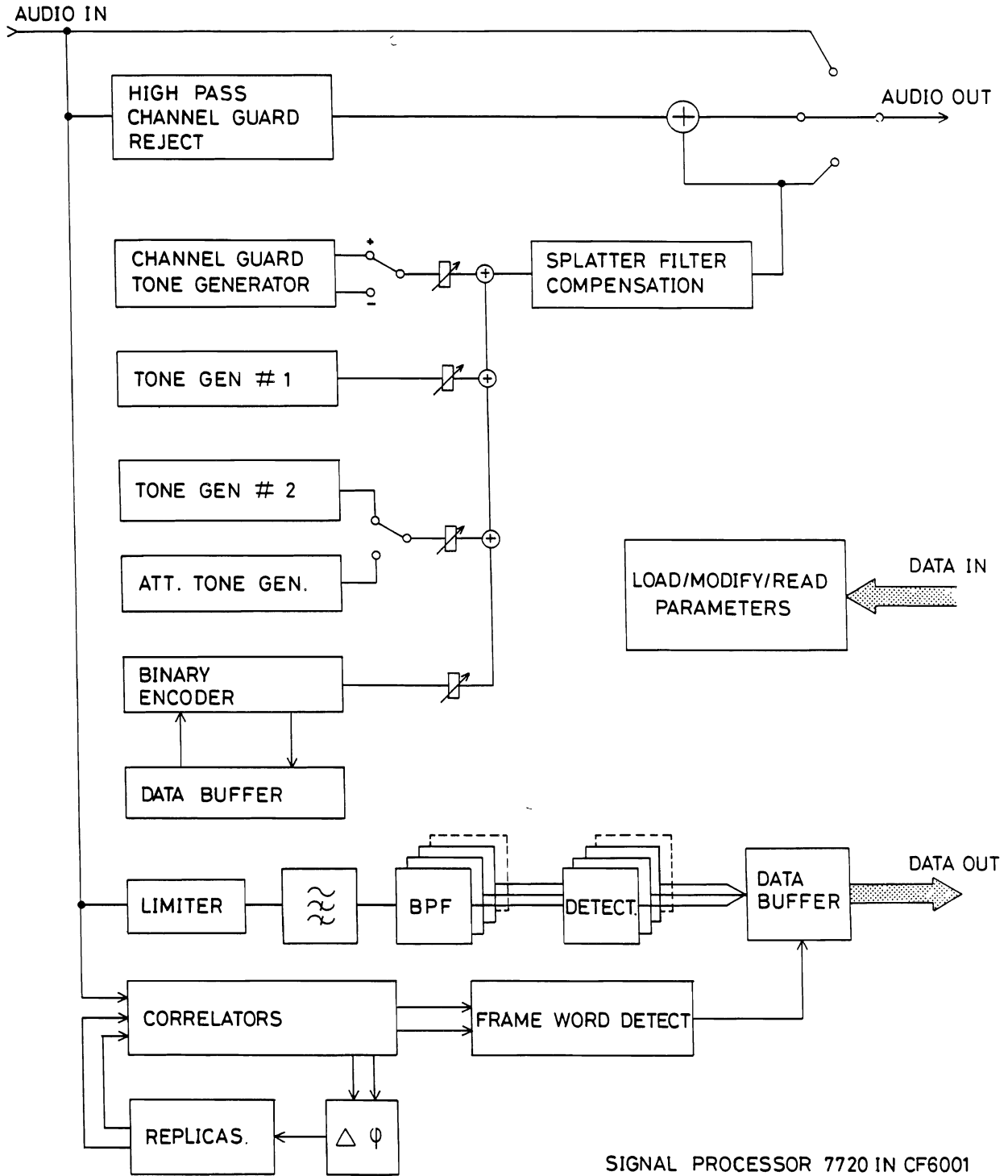

SIGNAL PROCESSOR 7720 IN CF6001
FUNCTIONAL BLOCK DIAGRAM

D404.293

CODEC, U802

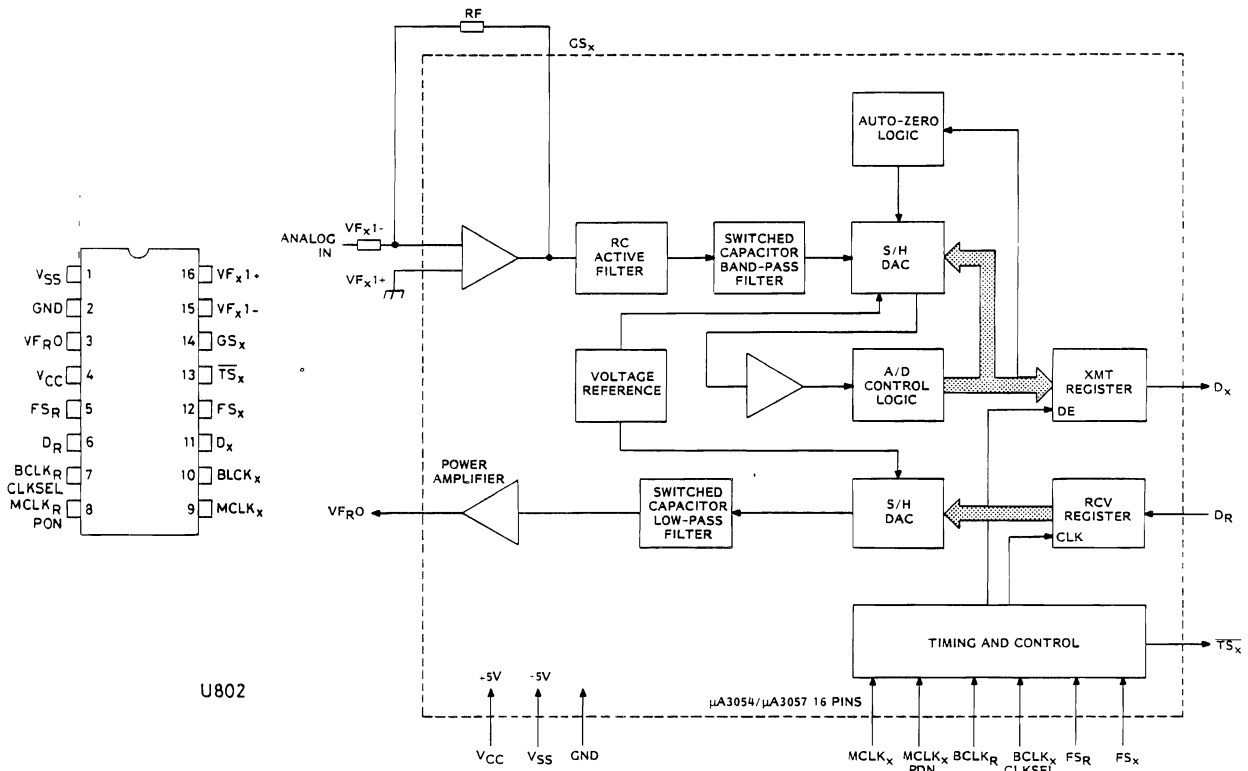

U802

The digitalised input/output signals are supplied to/from U801 via U802 (3054 Codec). The CODEC is a combined 8 bit u-law analogue to digital (A/D) and digital to analogue (D/A) converter.

All necessary filtering is included inside the IC to remove aliasing components and to shape the frequency response after the D/A process.

The necessary timing signals to generate the 7.7 kHz sampling are provided by dividing down the 7.4 MHz oscillator signal in U705b and U804.

AUDIO GENERATORS

Audio generators are implemented in the 7720 to be sequentially accessing values in a sine look-up table internal to the 7720. The frequency is determined by the magnitude of the phase increments from one sample to the next. Generators are used to generate sequential, DTMF, FFSK and supervisory tones. A special generator is required to produce the CTCSS tones and is capable of immediately altering its phase by 180 degrees for squelch tail elimination.

FFSK DEMODULATOR (Fast Frequency Shift Keying)

The FFSK is demodulated by correlating the input signal with a generator giving two output signals corresponding to the two possible FFSK states, '1' (1200 Hz) and '0' (1800 Hz) at 1200 baud, or 1200 Hz and 2400 Hz at 2400 baud. To obtain clock synchronisation the generator is locked to the input signal using two phase comparators, one for each possible input frequency.

SEQUENTIAL TONE DECODER

The input signal is limited to suppress noise and amplitude variations and then applied to 15, 2nd order bandpass filters corresponding to the 15 possible tones. The outputs from the filters are fed to the detectors where the level of the signal is converted to a 'signal present', 'no signal present' condition.

RX AUDIO PATH

The 110 mV RX line coming from the demodulator is passed via the analogue switch U810b to the deemphasis circuit U807. The signal then passes to the volume control formed by U805. The volume control is arranged to have nine steps with approximately 7 dB between each giving a maximum attenuation of 56 dB. The output from the volume control passes to the audio output amplifier U808. The amplifier consists of two separate amplifiers connected in a bridge configuration and in this mode is capable of supplying 10 W into 4 ohm. This configuration produces a floating output signal with respect to ground and care must be taken when measuring with instruments having grounded input terminals.

PROCESSED RX

The processed RX is a buffered version of the received audio signal taken from just before the volume control. The signal can be muted under software control.

TX AUDIO PATH

The microphone input is a standard STORNO 600 ohm/110 mV with a DC supply through the signal led from the CF6001. The microphone may be muted by removing this supply by switching Q801. Low frequency noise is attenuated in a 3rd order lowpass filter centered around U806b, and the signal is preemphasised in U806a.

The amplifier U806d forms a virtual earth mixing stage for the preemphasised microphone signal and the TX line signal.

The signals appear at the output of this stage at a nominal level of approximately 1 V RMS. The limiting action is performed by D801 with clipping levels set at approximately ± 2.5 V.

The stage U806c forms another summing point where the tones from the DECAP may be added. The splatter filter required to remove the harmonics generated by the limiter is formed by U807a, U807b and associated components. The filter is a fourth order design, the frequency response of which can be modified to accommodate both 12.5 and 25 kHz channel spacings by including R826, R830 for the latter.

SPECIFICATIONS

Operating voltage

10.8 V DC - 15.6 V DC (13.2 V nom.)

Current consumption (battery)

OFF:	(CF alone all outputs unloaded V _{batt.} = 13.2 V)	<10 mA
Stand-by:	(CF alone all outputs unloaded V _{batt.} = 13.2 V)	<275 mA
RX:	(10 W output into 4 ohm CF alone all outputs except LS unloaded V _{batt.} = 13.2 V)	<2.5 mA

Outputs

Open Collector J901 pin 16, 17.

High current outputs for switch units. <100 mA a V_{out} <0.5 V (diode protected for relay driving)

TX AUDIO PROCESSOR

Microphone input

110 mV for 60% of max. deviation at 1 kHz modulation frequency.

Gain

19 \pm 3 dB at 1 kHz, measured from mic. input to TX mod. output.

Audio Response

measured under non-limiting conditions.

100 Hz	<-30 dB
400 Hz	-8.5 \pm 1 dB
1000 Hz	0 dB (ref.)
2700 Hz	+8.2 \pm 1 dB
3000 Hz	+8.2 \pm 1 dB
6000 Hz	<-10 dB
25000 Hz	<-40 dB

Distortion

Max. 1% at 70% of max. deviation measured at 1 kHz.

TX line input

110 mV for 60% max. deviation at 1 kHz.

RX AUDIO PROCESSOR

RX line input

110 mV at 60% max. deviation at 1 kHz.

AUDIO POWER AMPLIFIER

Gain

46 dB \pm 3 dB at 1 kHz

Rload= 4 ohm

Rated output

Rload= 4 ohm

Vbatt= 13.2 V

Audio response

100 Hz	<+4 dB	
300 Hz	9 \pm 1.5 dB	
1000 Hz		0 dB (ref)
2700 Hz	-8.5 \pm 1 dB	
6000 Hz	-15.5 \pm 1 dB	

Volume control

9 levels of 7 \pm 1 dB= 56 dB.

More than 6 dB of excess gain is available.

Temperature range

Operating: -25^oC to +60^oC

Storage: -40^oC to +70^oC

Mechanical dimensions

L x W x H: 162 x 127 x 22 mm

Weight

200 g

REAR CONN
J901

PA
P905

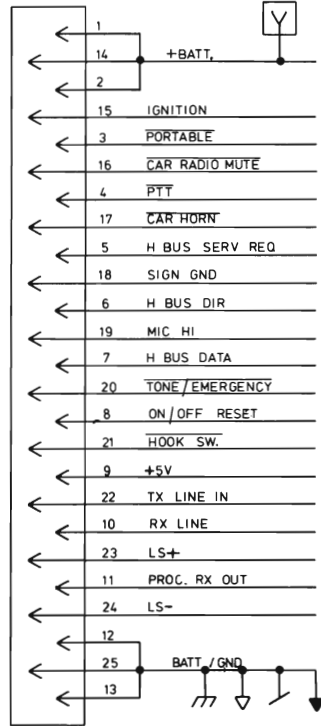

RF CONN,
P902

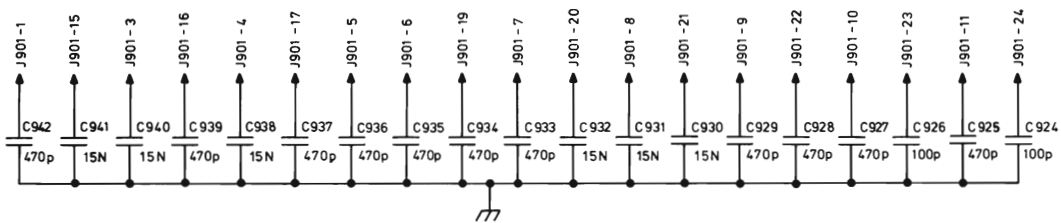
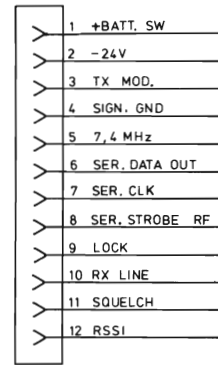

NOTE:
COMPONENTS MARK
PLACED ON COMPON

OPTION CONN.
J904

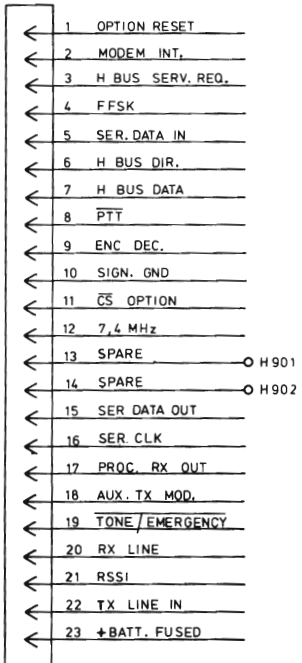

FRONT CONN
J903

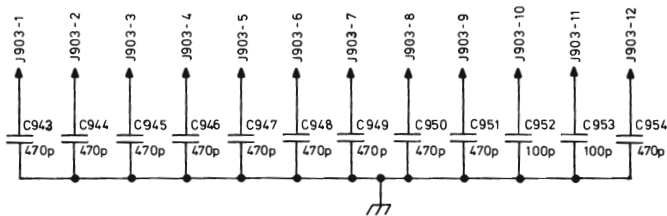
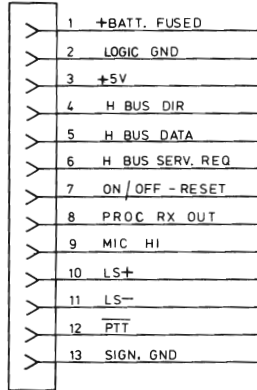

OPTION CONN
J906

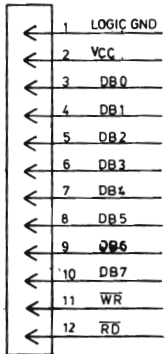

>>THIS DOCUMENT REMAINS STORNO'S PROPERTY AND STORNO RESERVES ALL RIGHTS IN RESPECT TO THIS DOCUMENT. WITHOUT STORNO'S WRITTEN PERMISSION THE CONTENTS OF THE DOCUMENT MUST NOT BE IMPARTED TO A THIRD PARTY NOR BE USED FOR ANY UNAUTHORIZED PURPOSE<<

MARKED RXXX ARE COMPONENT SIDE.

PA
P905

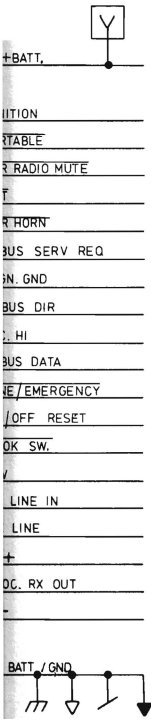

RF CONN.
P902

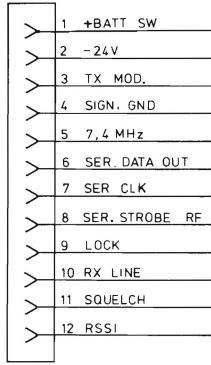

OPTION CONN
J904

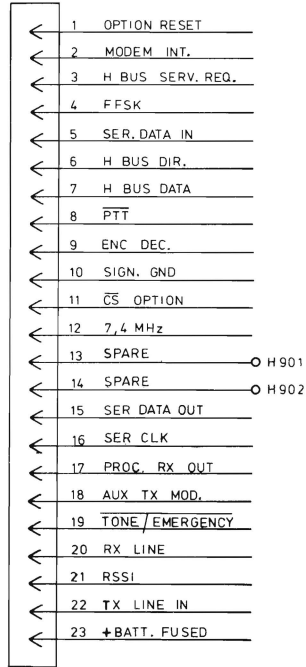

FRONT CONN
J903

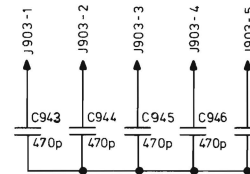
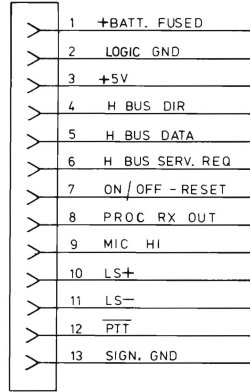

OPTION CONN
J906

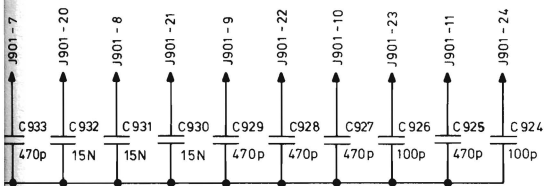
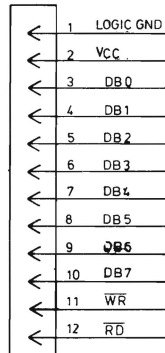

NOTE:
COMPONENTS MARKED RXXX ARE
PLACED ON COMPONENT SIDE.

>>THIS DOCUMENT REMAINS STORNO'S PROPERTY
AND STORNO RESERVES ALL RIGHTS IN RESPECT
TO THIS DOCUMENT. WITHOUT STORNO'S WRITTEN
PERMISSION THE CONTENTS OF THE DOCUMENT
MUST NOT BE IMPARTED TO A THIRD PARTY NOR
BE USED FOR ANY UNAUTHORIZED PURPOSE<<

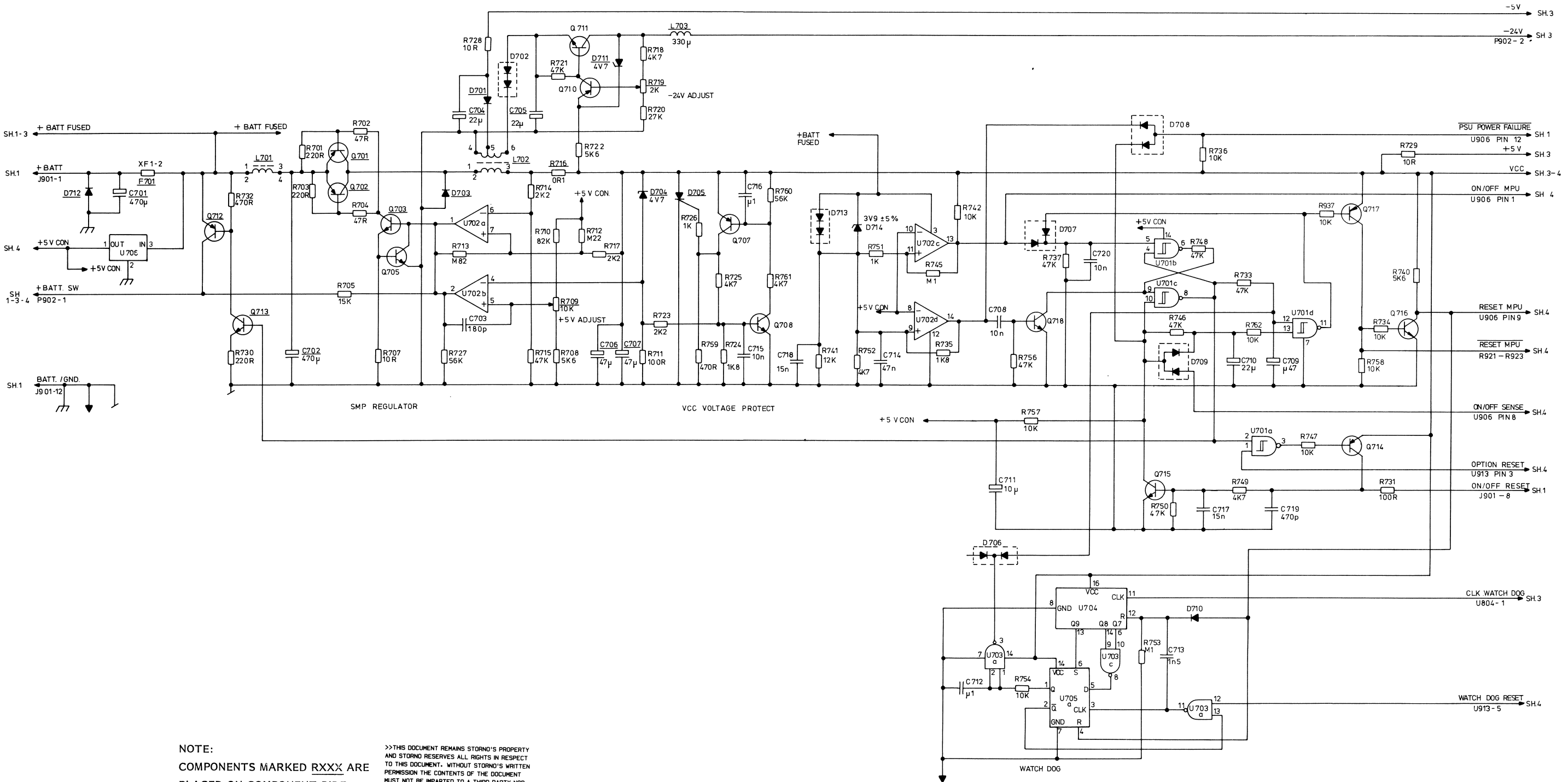

NOTE:
COMPONENTS MARKED RXXX ARE
PLACED ON COMPONENT SIDE.

>>>THIS DOCUMENT REMAINS STORNO'S PROPERTY
AND STORNO RESERVES ALL RIGHTS IN RESPECT
TO THIS DOCUMENT. WITHOUT STORNO'S WRITTEN
PERMISSION THE CONTENTS OF THE DOCUMENT
MUST NOT BE IMPARTED TO A THIRD PARTY NOR
BE USED FOR ANY UNAUTHORIZED PURPOSE<<<

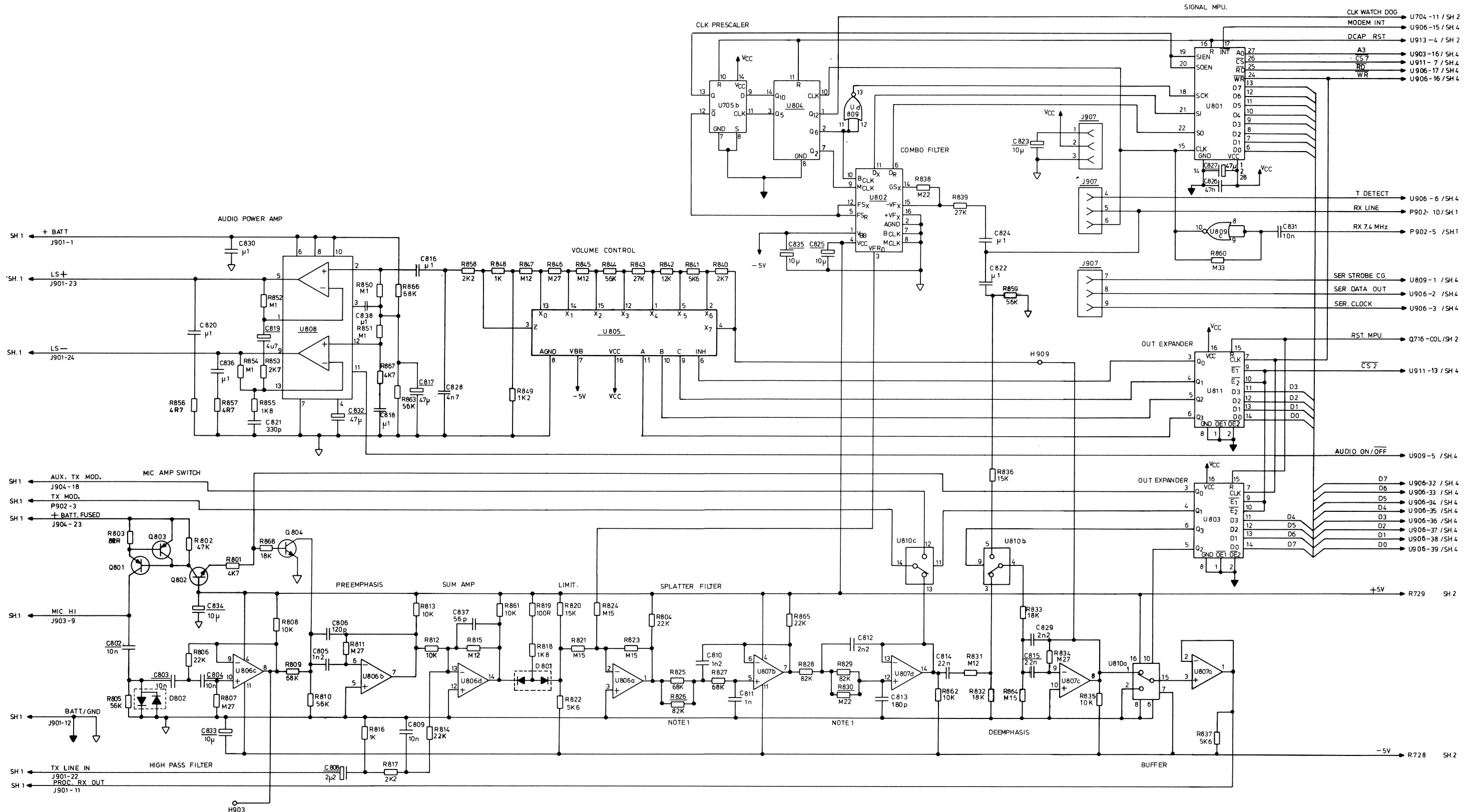

NOTE:
COMPONENTS MARKED RXXX ARE
PLACED ON COMPONENT SIDE.

NOTE 1: REMOVE AT 125 KHz
CHANNEL SPACING

>>>THIS DOCUMENT REMAINS STORNO'S PROPERTY
AND STORNO RESERVES ALL RIGHTS IN RESPECT
TO THIS DOCUMENT. WITHOUT STORNO'S WRITTEN
PERMISSION THE CONTENTS OF THE DOCUMENT
MUST NOT BE IMPARTED TO A THIRD PARTY NOR
BE USED FOR ANY UNAUTHORIZED PURPOSE<<<

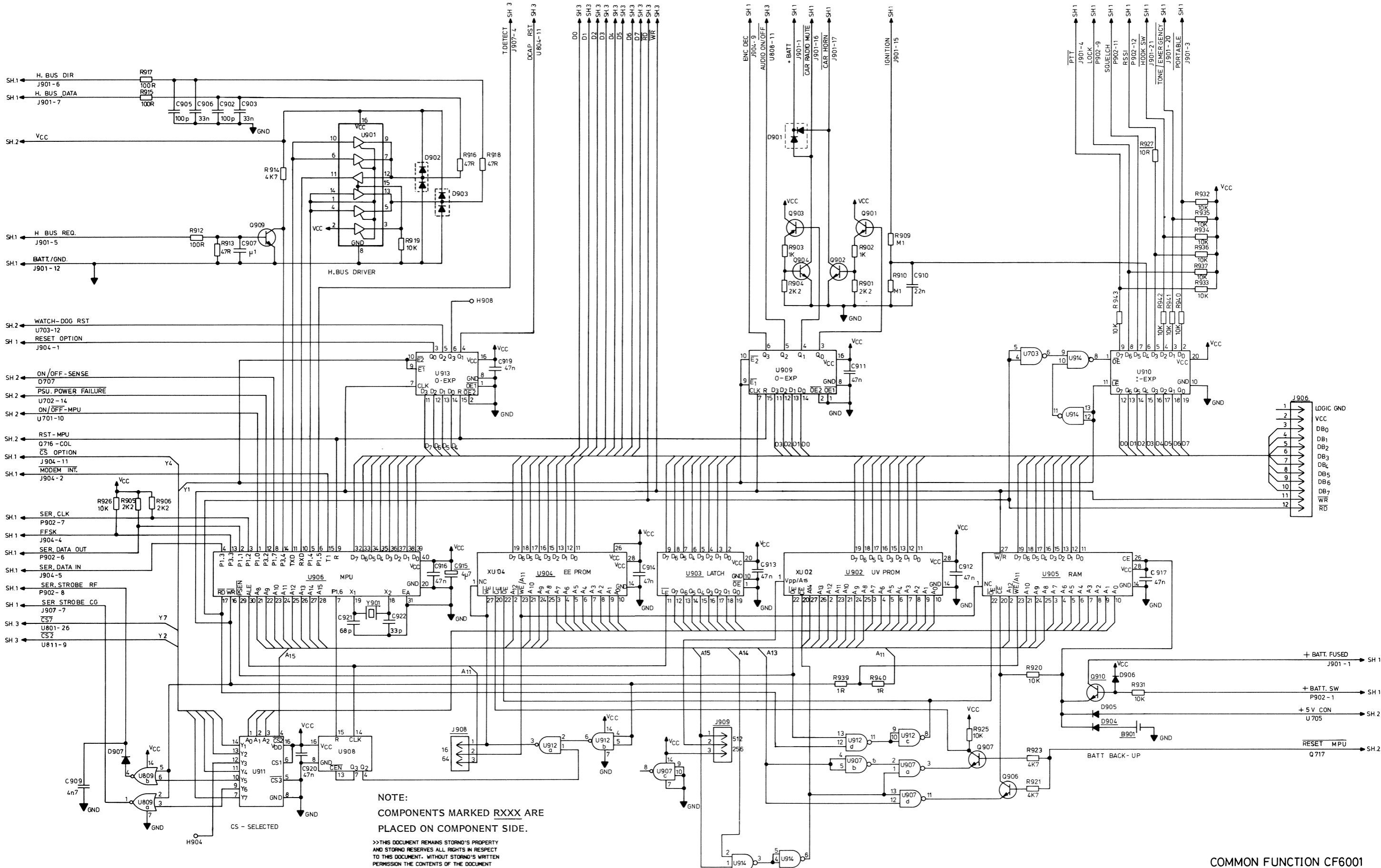

NOTE:
COMPONENTS MARKED RXXX ARE
PLACED ON COMPONENT SIDE.

>>>THIS DOCUMENT REMAINS STORNO'S PROPERTY
AND STORNO RESERVES ALL RIGHTS IN RESPECT
TO THIS DOCUMENT. WITHOUT STORNO'S WRITTEN
PERMISSION THE CONTENTS OF THE DOCUMENT
MUST NOT BE IMPARTED TO A THIRD PARTY NOR
BE USED FOR ANY UNAUTHORIZED PURPOSE<<<

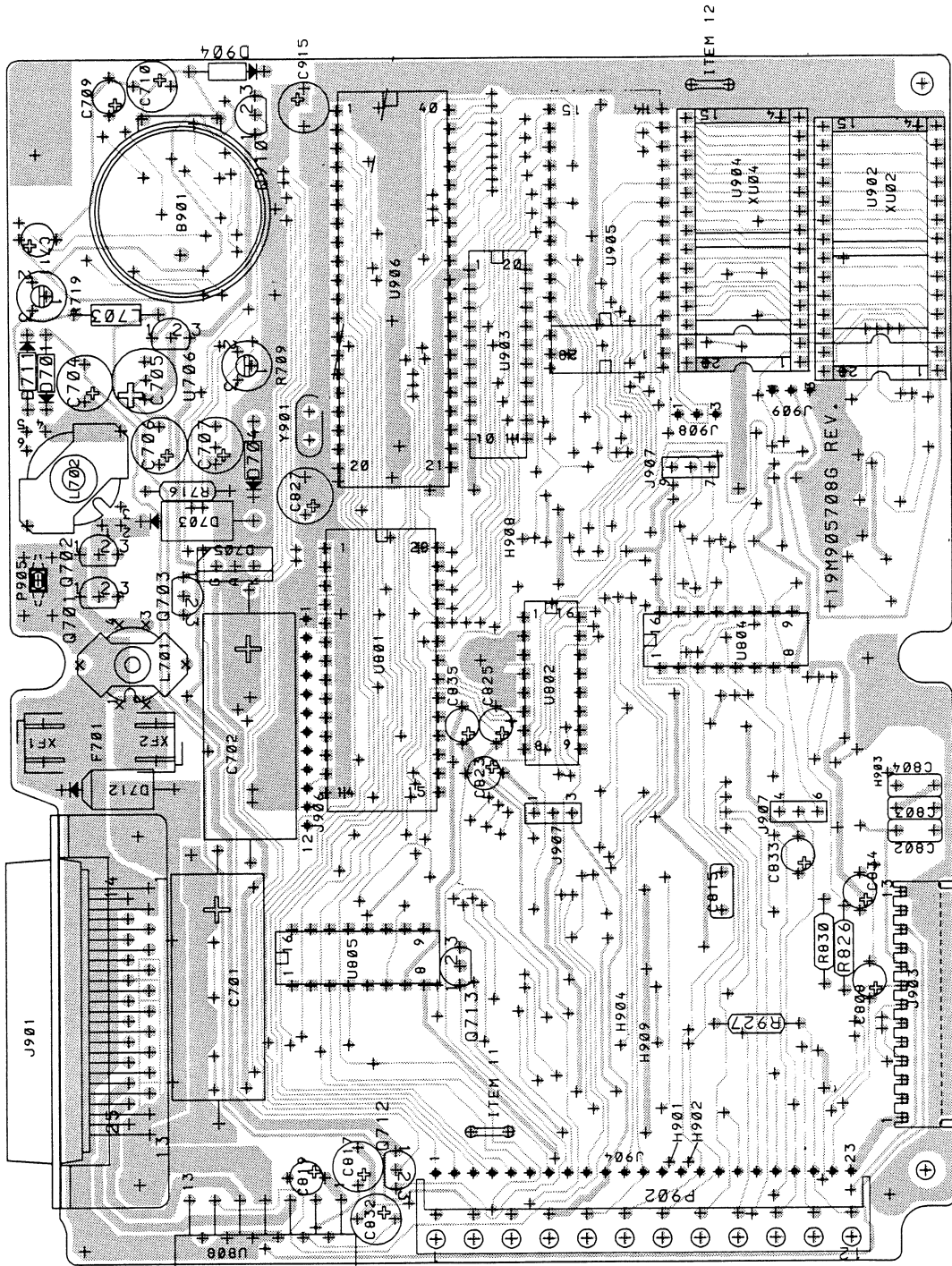

COMMON FUNCTION CF6001
COMPONENT LAYOUT - COMPONENT SIDE

CODE NO. M905708G1

REV. 2

D404.451

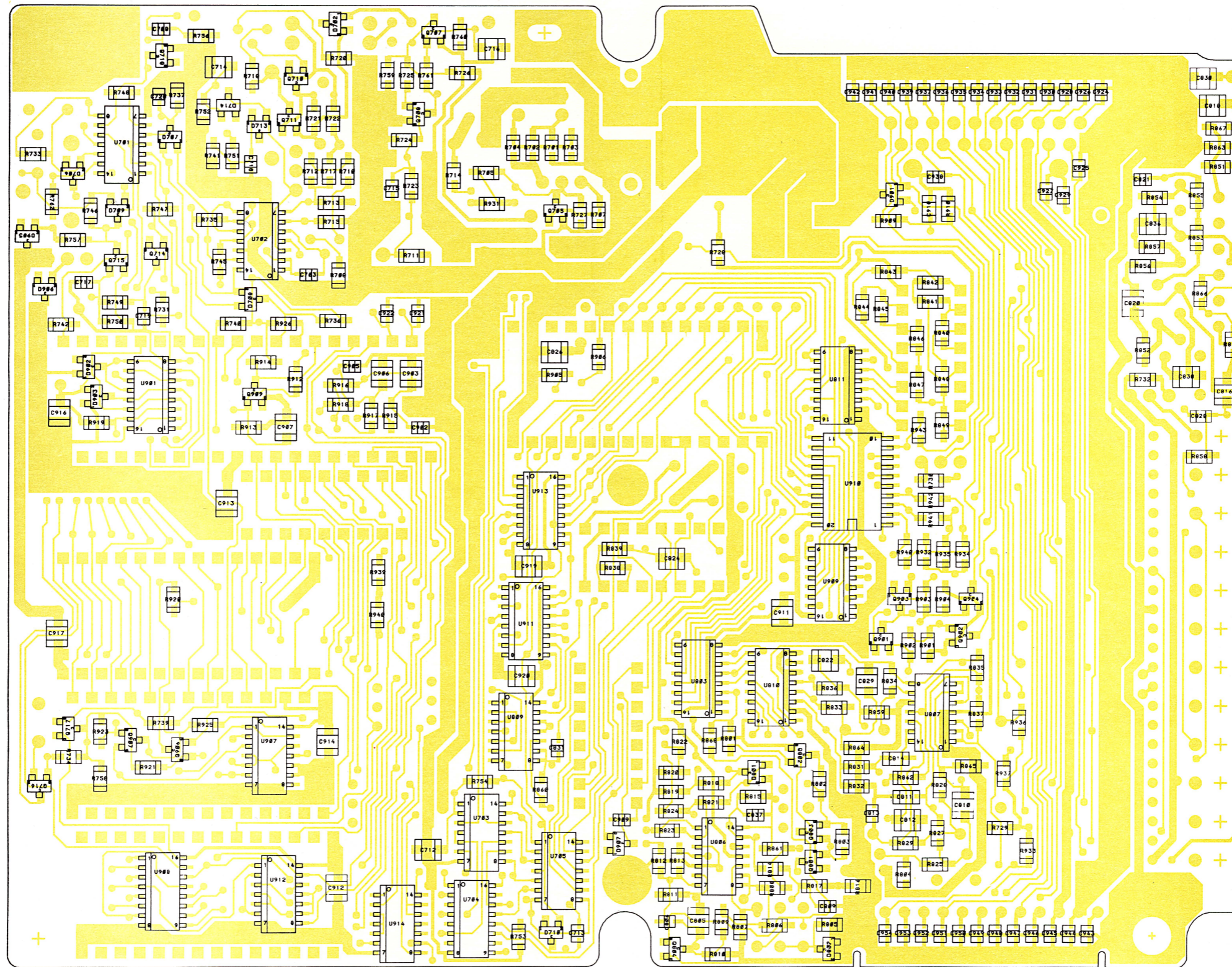

COMMON FUNCTION CF6001
COMPONENT LAYOUT - CHIP SIDE

CODE NO. M905708G1

REV. 2

D404.452

Storno**Storno**

Pos.	Code No.	Description	Qt.
C921	J707436P53	CAP CER NPO 68P 5% 50V	1
C922	J707436P37	CAP CER NPO 33P 5% 50V	1
C924	J707436P61	CAP CER NPO 100P 5% 50V	1
C925	J707438P3	CAP CER CL2 470P 10% 50V	1
C926	J707436P61	CAP CER NPO 100P 5% 50V	1
C927	J707438P3	CAP CER CL2 470P 10% 50V	1
C928	J707438P3	CAP CER CL2 470P 10% 50V	1
C929	J707438P3	CAP CER CL2 470P 10% 50V	1
C930	J707438P3	CAP CER CL2 470P 10% 50V	1
C931	J707438P3	CAP CER CL2 470P 10% 50V	1
C932	J707438P3	CAP CER CL2 470P 10% 50V	1
C933	J707438P3	CAP CER CL2 470P 10% 50V	1
C934	J707438P3	CAP CER CL2 470P 10% 50V	1
C935	J707438P3	CAP CER CL2 470P 10% 50V	1
C936	J707438P3	CAP CER CL2 470P 10% 50V	1
C937	J707438P3	CAP CER CL2 470P 10% 50V	1
C938	J707438P3	CAP CER CL2 470P 10% 50V	1
C939	J707438P3	CAP CER CL2 470P 10% 50V	1
C940	J707438P3	CAP CER CL2 470P 10% 50V	1
C941	J707438P3	CAP CER CL2 470P 10% 50V	1
C942	J707438P3	CAP CER CL2 470P 10% 50V	1
C943	J707438P3	CAP CER CL2 470P 10% 50V	1
C944	J707438P3	CAP CER CL2 470P 10% 50V	1
C945	J707438P3	CAP CER CL2 470P 10% 50V	1
C946	J707438P3	CAP CER CL2 470P 10% 50V	1
C947	J707438P3	CAP CER CL2 470P 10% 50V	1
C948	J707438P3	CAP CER CL2 470P 10% 50V	1
C949	J707438P3	CAP CER CL2 470P 10% 50V	1
C950	J707438P3	CAP CER CL2 470P 10% 50V	1
C951	J707438P3	CAP CER CL2 470P 10% 50V	1
C952	J707436P61	CAP CER NPO 100P 5% 50V	1
C953	J707436P61	CAP CER NPO 100P 5% 50V	1
C954	J707438P3	CAP CER CL2 470P 10% 50V	1
D701	A700028P1	DIO SI SIG 1N4148	1
D702	J707389P1	DIO SI SIG BAV 99	1
D703	J708734P1	DIO SI PWR BYV 28-100	1

Pos.	Code No.	Description	Qt.
D704	J706270P5	DIO SI ZENR 4V7 2% 0,4W	1
D705	J709207P1	THYRSTR SCR X0403 1.7A 50	1
D706	A700025P5	DIO SI ZENR 4V7 5% 0,4W	1
D707	J707390P1	DIO SI SIG BAV 74	1
D708	J708681P1	DIO SI SIG BAW 56	1
D709	J707389P1	DIO SI SIG BAV 99	1
D710	J707390P1	DIO SI SIG BAV 74	1
D711	A700025P5	DIO SI ZENR 4V7 5% 0,4W	1
D712	J708407P2	DIO SI SUPPR 1N6278 20V	1
D713	J707389P1	DIO SI SIG BAV 99	1
D801	J708681P1	DIO SI SIG BAW 56	1
D802	J707389P1	DIO SI SIG BAV 99	1
D901	J707390P1	DIO SI SIG BAV 74	1
D902	J707389P1	DIO SI SIG BAV 99	1
D903	J707389P1	DIO SI SIG BAV 99	1
D904	A700028P1	DIO SI SIG 1N4148	1
D905	J707390P1	DIO SI SIG BAV 74	1
D906	J707390P1	DIO SI SIG BAV 74	1
D907	J707390P1	DIO SI SIG BAV 74	1
F701	J706998P7	FUSE CTG 2.OA T	1
J901	J709522G1	CONN MODIFICATION	1
J903	A700041P87	CONN PWB FEM 13 CKT	1
J904	J7089225P3	CONN PT PIN L-19,25	23
J906	J7089225P3	CONN PT PIN L-19,25	12
J907	J707300P3	CONNECTOR SOC IN LINE	3
J908	J7089225P2	CONN PT PIN L-11,7	4
J909	J7089225P2	CONN PT PIN L-11,7	3
L701	K805758G1	COIL ASM	1
L702	K805559G1	COIL ASM	1
L703	A700024P43	COIL RF FIX 330UH 10%	1
P902	J707064P112	CONN PWB FEM 12-CKT	1
P905	A701883P4	CONT EL	1
Q701	J707435P1	TSTR PNP SI BC 369	1
Q702	J707435P1	TSTR PNP SI BC 369	1
Q703	J707267P2	TSTR NPN SI BC338-25	1
Q705	J707386P1	TSTR NPN SI BCW 32	1

Parts List

COMMON FUNCTION BOARD CF6001 : M905708G1

X404.462

Page No. 2/6

Pos.	Code No.	Description	Qt.
C921	J707436P53	CAP CER NPO 68P 5% 50V	1
C922	J707436P37	CAP CER NPO 33P 5% 50V	1
C924	J707436P61	CAP CER NPO 100P 5% 50V	1
C925	J707438P3	CAP CER CL2 470P 10% 50V	1
C926	J707436P61	CAP CER NPO 100P 5% 50V	1
C927	J707438P3	CAP CER CL2 470P 10% 50V	1
C928	J707438P3	CAP CER CL2 470P 10% 50V	1
C929	J707438P3	CAP CER CL2 470P 10% 50V	1
C930	J707438P3	CAP CER CL2 470P 10% 50V	1
C931	J707438P3	CAP CER CL2 470P 10% 50V	1
C932	J707438P3	CAP CER CL2 470P 10% 50V	1
C933	J707438P3	CAP CER CL2 470P 10% 50V	1
C934	J707438P3	CAP CER CL2 470P 10% 50V	1
C935	J707438P3	CAP CER CL2 470P 10% 50V	1
C936	J707438P3	CAP CER CL2 470P 10% 50V	1
C937	J707438P3	CAP CER CL2 470P 10% 50V	1
C938	J707438P3	CAP CER CL2 470P 10% 50V	1
C939	J707438P3	CAP CER CL2 470P 10% 50V	1
C940	J707438P3	CAP CER CL2 470P 10% 50V	1
C941	J707438P3	CAP CER CL2 470P 10% 50V	1
C942	J707438P3	CAP CER CL2 470P 10% 50V	1
C943	J707438P3	CAP CER CL2 470P 10% 50V	1
C944	J707438P3	CAP CER CL2 470P 10% 50V	1
C945	J707438P3	CAP CER CL2 470P 10% 50V	1
C946	J707438P3	CAP CER CL2 470P 10% 50V	1
C947	J707438P3	CAP CER CL2 470P 10% 50V	1
C948	J707438P3	CAP CER CL2 470P 10% 50V	1
C949	J707438P3	CAP CER CL2 470P 10% 50V	1
C950	J707438P3	CAP CER CL2 470P 10% 50V	1
C951	J707438P3	CAP CER CL2 470P 10% 50V	1
C952	J707436P61	CAP CER NPO 100P 5% 50V	1
C953	J707436P61	CAP CER NPO 100P 5% 50V	1
C954	J707438P3	CAP CER CL2 470P 10% 50V	1
D701	A700028P1	DIO SI SIG 1N4148	1
D702	J707389P1	DIO SI SIG BAV 99	1
D703	J708734P1	DIO SI PWR BYV 28-100	1

Pos.	Code No.	Description	Qt.
D704	J706270P5	DIO SI ZENR 4V7 2% 0,4W	1
D705	J709207P1	THYRSTR SCR X0403 1.7A 50	1
D706	A700025P5	DIO SI ZENR 4V7 5% 0,4W	1
D707	J707390P1	DIO SI SIG BAV 74	1
D708	J708681P1	DIO SI SIG BAW 56	1
D709	J707389P1	DIO SI SIG BAV 99	1
D710	J707390P1	DIO SI SIG BAV 74	1
D711	A700025P5	DIO SI ZENR 4V7 5% 0,4W	1
D712	J708407P2	DIO SI SUPPR 1N6278 20V	1
D713	J707389P1	DIO SI SIG BAV 99	1
D801	J708681P1	DIO SI SIG BAW 56	1
D802	J707389P1	DIO SI SIG BAV 99	1
D901	J707390P1	DIO SI SIG BAV 74	1
D902	J707389P1	DIO SI SIG BAV 99	1
D903	J707389P1	DIO SI SIG BAV 99	1
D904	A700028P1	DIO SI SIG 1N4148	1
D905	J707390P1	DIO SI SIG BAV 74	1
D906	J707390P1	DIO SI SIG BAV 74	1
D907	J707390P1	DIO SI SIG BAV 74	1
F701	J706998P7	FUSE CTG 2.0A T	1
J901	J709522G1	CONN MODIFICATION	1
J903	A700041P87	CONN PWB FEM 13 CKT	1
J904	J708925P3	CONN PT PIN L-19,25	23
J906	J708925P3	CONN PT PIN L-19,25	12
J907	J707300P3	CONNECTOR SOC IN LINE	3
J908	J708925P2	CONN PT PIN L-11,7	4
J909	J708925P2	CONN PT PIN L-11,7	3
L701	K805758G1	COIL ASM	1
L702	K805559G1	COIL ASM	1
L703	A700024P43	COIL RF FIX 330UH 10%	1
P902	J707064P112	CONN PWB FEM 12-CKT	1
P905	A701883P4	CONT EL	1
Q701	J707435P1	TSTR PNP SI BC 369	1
Q702	J707435P1	TSTR PNP SI BC 369	1
Q703	J707267P2	TSTR NPN SI BC338-25	1
Q705	J707386P1	TSTR NPN SI BCW 32	1

Storno**Storno**

Pos.	Code No.	Description	Qt.
Q707	J707387P1	TSTR PNP SI BCW 30	1
Q708	J707386P1	TSTR NPN SI BCW 32	1
Q710	J707387P1	TSTR PNP SI BCW 30	1
Q711	J707386P1	TSTR NPN SI BCW 32	1
Q712	J707435P1	TSTR PNP SI BC 369	1
Q713	J707511P1	TSTR NPN SI BC 548A/B	1
Q714	J707387P1	TSTR PNP SI BCW 30	1
Q715	J707386P1	TSTR NPN SI BCW 32	1
Q716	J707387P1	TSTR PNP SI BCW 30	1
Q801	J707387P1	TSTR PNP SI BCW 30	1
Q802	J707386P1	TSTR NPN SI BCW 32	1
Q803	J707387P1	TSTR PNP SI BCW 30	1
Q804	J707386P1	TSTR NPN SI BCW 32	1
Q901	J707386P1	TSTR NPN SI BCW 32	1
Q902	J707429P1	TSTR NPN SI BCX 20	1
Q903	J707386P1	TSTR NPN SI BCW 32	1
Q904	J707429P1	TSTR NPN SI BCX 20	1
Q905	J707388P1	TSTR NPN SI BFR 53	1
Q906	J707386P1	TSTR NPN SI BCW 32	1
Q907	J707386P1	TSTR NPN SI BCW 32	1
Q909	J707386P1	TSTR NPN SI BCW 32	1
Q910	J707511P1	TSTR NPN SI BC 548A/B	1
Q911	J707386P1	TSTR NPN SI BCW 32	1
R701	J707385P221	RES MFILM 220R 5% 1/8W	1
R702	J707385P470	RES MFILM 47R 5% 1/8W	1
R703	J707385P221	RES MFILM 220R 5% 1/8W	1
R704	J707385P470	RES MFILM 47R 5% 1/8W	1
R705	J707385P153	RES MFILM 15K 5% 1/8W	1
R706	J707385P152	RES MFILM 1K5 5% 1/8W	1
R707	J707385P100	RES MFILM 10R 5% 1/8W	1
R708	J707385P562	RES MFILM 5K6 5% 1/8W	1
R709	J708538P5	RES VAR CER 10K 20% 0,5W	1
R710	J707385P823	RES MFILM 82K 5% 1/8W	1
R711	J707385P101	RES MFILM 100R 5% 1/8W	1
R712	J707385P224	RES MFILM 220K 5% 1/8W	1
R713	J707385P824	RES MFILM 820K 5% 1/8W	1

Pos.	Code No.	Description	Qt.
R714	J707385P222	RES MFILM 2K2 5% 1/8W	1
R715	J707385P473	RES MFILM 47K 5% 1/8W	1
R716	J709247P1	RES MFILM 0,1R 10% 1/4W	1
R717	J707385P222	RES MFILM 2K2 5% 1/8W	1
R718	J707385P472	RES MFILM 4K7 5% 1/8W	1
R719	J708538P3	RES VAR CER 2K 20% 0,5W	1
R720	J707385P273	RES MFILM 27K 5% 1/8W	1
R721	J707385P473	RES MFILM 47K 5% 1/8W	1
R722	J707385P562	RES MFILM 5K6 5% 1/8W	1
R723	J707385P222	RES MFILM 2K2 5% 1/8W	1
R724	J707385P182	RES MFILM 1K8 5% 1/8W	1
R725	J707385P472	RES MFILM 4K7 5% 1/8W	1
R726	J707385P102	RES MFILM 1K0 5% 1/8W	1
R727	J707385P563	RES MFILM 56K 5% 1/8W	1
R728	J707385P100	RES MFILM 10R 5% 1/8W	1
R729	J707385P100	RES MFILM 10R 5% 1/8W	1
R730	J707385P221	RES MFILM 220R 5% 1/8W	1
R731	J707385P101	RES MFILM 100R 5% 1/8W	1
R732	J707385P471	RES MFILM 470R 5% 1/8W	1
R733	J707385P563	RES MFILM 56K 5% 1/8W	1
R734	J707385P103	RES MFILM 10K 5% 1/8W	1
R735	J707385P684	RES MFILM 680K 5% 1/8W	1
R736	J707385P104	RES MFILM 100K 5% 1/8W	1
R737	J707385P473	RES MFILM 47K 5% 1/8W	1
R738	J707385P184	RES MFILM 180K 5% 1/8W	1
R739	J707385P103	RES MFILM 10K 5% 1/8W	1
R740	J707385P562	RES MFILM 5K6 5% 1/8W	1
R741	J707385P103	RES MFILM 10K 5% 1/8W	1
R742	J707385P103	RES MFILM 10K 5% 1/8W	1
R743	J707385P104	RES MFILM 100K 5% 1/8W	1
R744	J707385P104	RES MFILM 100K 5% 1/8W	1
R745	J707385P474	RES MFILM 470K 5% 1/8W	1
R746	J707385P473	RES MFILM 47K 5% 1/8W	1
R747	J707385P103	RES MFILM 10K 5% 1/8W	1
R748	J707385P473	RES MFILM 47K 5% 1/8W	1
R749	J707385P472	RES MFILM 4K7 5% 1/8W	1

Parts List

COMMON FUNCTION BOARD CF6001 : M905708G1

X404.462

Pos.	Code No.	Description	Qt.
R750	J707385P473	RES MFILM 47K 5% 1/8W	1
R751	J707385P222	RES MFILM 2K2 5% 1/8W	1
R752	J707385P472	RES MFILM 4K7 5% 1/8W	1
R753	J707385P104	RES MFILM 100K 5% 1/8W	1
R754	J707385P103	RES MFILM 10K 5% 1/8W	1
R755	J707385P473	RES MFILM 47K 5% 1/8W	1
R756	J707385P122	RES MFILM 1K2 5% 1/8W	1
R757	J707385P103	RES MFILM 10K 5% 1/8W	1
R758	J707385P103	RES MFILM 10K 5% 1/8W	1
R759	J707385P471	RES MFILM 470R 5% 1/8W	1
R760	J707385P563	RES MFILM 56K 5% 1/8W	1
R761	J707385P472	RES MFILM 4K7 5% 1/8W	1
R801	J707385P472	RES MFILM 4K7 5% 1/8W	1
R802	J707385P473	RES MFILM 47K 5% 1/8W	1
R803	J707385P820	RES MFILM 82R 5% 1/8W	1
R804	J707385P223	RES MFILM 22K 5% 1/8W	1
R805	J707385P563	RES MFILM 56K 5% 1/8W	1
R806	J707385P223	RES MFILM 22K 5% 1/8W	1
R807	J707385P274	RES MFILM 270K 5% 1/8W	1
R808	J707385P103	RES MFILM 10K 5% 1/8W	1
R809	J707385P683	RES MFILM 68K 5% 1/8W	1
R810	J707385P563	RES MFILM 56K 5% 1/8W	1
R811	J707385P274	RES MFILM 270K 5% 1/8W	1
R812	J707385P103	RES MFILM 10K 5% 1/8W	1
R813	J707385P103	RES MFILM 10K 5% 1/8W	1
R814	J707385P223	RES MFILM 22K 5% 1/8W	1
R815	J707385P124	RES MFILM 120K 5% 1/8W	1
R816	J707385P102	RES MFILM 1K0 5% 1/8W	1
R817	J707385P222	RES MFILM 2K2 5% 1/8W	1
R818	J707385P182	RES MFILM 1K8 5% 1/8W	1
R819	J707385P101	RES MFILM 100R 5% 1/8W	1
R820	J707385P153	RES MFILM 15K 5% 1/8W	1
R821	J707385P154	RES MFILM 150K 5% 1/8W	1
R822	J707385P562	RES MFILM 5K6 5% 1/8W	1
R823	J707385P154	RES MFILM 150K 5% 1/8W	1
R824	J707385P154	RES MFILM 150K 5% 1/8W	1

Pos.	Code No.	Description	Qt.
R825	J707385P683	RES MFILM 68K 5% 1/8W	1
R826	A700019P60	RES DEPC 82K 5% 1/4W	1
R827	J707385P683	RES MFILM 68K 5% 1/8W	1
R828	J707385P823	RES MFILM 82K 5% 1/8W	1
R829	J707385P823	RES MFILM 82K 5% 1/8W	1
R830	A700019P65	RES DEPC 220K 5% 1/4W	1
R831	J707385P124	RES MFILM 120K 5% 1/8W	1
R832	J707385P183	RES MFILM 18K 5% 1/8W	1
R833	J707385P183	RES MFILM 18K 5% 1/8W	1
R834	J707385P274	RES MFILM 270K 5% 1/8W	1
R835	J707385P103	RES MFILM 10K 5% 1/8W	1
R836	J707385P153	RES MFILM 15K 5% 1/8W	1
R837	J707385P562	RES MFILM 5K6 5% 1/8W	1
R838	J707385P224	RES MFILM 220K 5% 1/8W	1
R839	J707385P273	RES MFILM 27K 5% 1/8W	1
R840	J707385P272	RES MFILM 2K7 5% 1/8W	1
R841	J707385P562	RES MFILM 5K6 5% 1/8W	1
R842	J707385P123	RES MFILM 12K 5% 1/8W	1
R843	J707385P273	RES MFILM 27K 5% 1/8W	1
R844	J707385P563	RES MFILM 56K 5% 1/8W	1
R845	J707385P124	RES MFILM 120K 5% 1/8W	1
R846	J707385P274	RES MFILM 270K 5% 1/8W	1
R847	J707385P124	RES MFILM 120K 5% 1/8W	1
R848	J707385P102	RES MFILM 1K0 5% 1/8W	1
R849	J707385P122	RES MFILM 1K2 5% 1/8W	1
R850	J707385P104	RES MFILM 100K 5% 1/8W	1
R851	J707385P104	RES MFILM 100K 5% 1/8W	1
R852	J707385P104	RES MFILM 100K 5% 1/8W	1
R853	J707385P272	RES MFILM 2K7 5% 1/8W	1
R854	J707385P104	RES MFILM 100K 5% 1/8W	1
R855	J707385P182	RES MFILM 1K8 5% 1/8W	1
R856	J707385P947	RES MFILM 4R7 20% 1/8W	1
R857	J707385P947	RES MFILM 4R7 20% 1/8W	1
R858	J707385P222	RES MFILM 2K2 5% 1/8W	1
R859	J707385P563	RES MFILM 5K6 5% 1/8W	1
R860	J707385P334	RES MFILM 330K 5% 1/8W	1

Storno**Storno**

Pos.	Code No.	Description	Qt.
R861	J707385P103	RES MFILM 10K 5% 1/8W	1
R862	J707385P103	RES MFILM 10K 5% 1/8W	1
R863	J707385P563	RES MFILM 56K 5% 1/8W	1
R864	J707385P154	RES MFILM 150K 5% 1/8W	1
R865	J707385P223	RES MFILM 22K 5% 1/8W	1
R866	J707385P683	RES MFILM 68K 5% 1/8W	1
R867	J707385P472	RES MFILM 4K7 5% 1/8W	1
R868	J707385P183	RES MFILM 18K 5% 1/8W	1
R901	J707385P222	RES MFILM 2K2 5% 1/8W	1
R902	J707385P102	RES MFILM 1K0 5% 1/8W	1
R903	J707385P102	RES MFILM 1K0 5% 1/8W	1
R904	J707385P222	RES MFILM 2K2 5% 1/8W	1
R905	J707385P222	RES MFILM 2K2 5% 1/8W	1
R906	J707385P222	RES MFILM 2K2 5% 1/8W	1
R907	J707385P123	RES MFILM 12K 5% 1/8W	1
R908	J707385P103	RES MFILM 10K 5% 1/8W	1
R909	J707385P104	RES MFILM 100K 5% 1/8W	1
R910	J707385P104	RES MFILM 100K 5% 1/8W	1
R912	J707385P101	RES MFILM 100R 5% 1/8W	1
R913	J707385P470	RES MFILM 47R 5% 1/8W	1
R914	J707385P472	RES MFILM 4K7 5% 1/8W	1
R915	J707385P101	RES MFILM 100R 5% 1/8W	1
R916	J707385P470	RES MFILM 47R 5% 1/8W	1
R917	J707385P101	RES MFILM 100R 5% 1/8W	1
R918	J707385P470	RES MFILM 47R 5% 1/8W	1
R919	J707385P103	RES MFILM 10K 5% 1/8W	1
R920	J707385P103	RES MFILM 10K 5% 1/8W	1
R921	J707385P472	RES MFILM 4K7 5% 1/8W	1
R922	J707385P103	RES MFILM 10K 5% 1/8W	1
R923	J707385P472	RES MFILM 4K7 5% 1/8W	1
R925	J707385P103	RES MFILM 10K 5% 1/8W	1
R926	J707385P103	RES MFILM 10K 5% 1/8W	1
R927	A700019P13	RES DEPC 10R 5% 1/4W	1
R931	J707385P103	RES MFILM 10K 5% 1/8W	1
R932	J707385P103	RES MFILM 10K 5% 1/8W	1
R933	J707385P103	RES MFILM 10K 5% 1/8W	1

Pos.	Code No.	Description	Qt.
R934	J707385P103	RES MFILM 10K 5% 1/8W	1
R935	J707385P103	RES MFILM 10K 5% 1/8W	1
R936	J707385P103	RES MFILM 10K 5% 1/8W	1
R937	J707385P103	RES MFILM 10K 5% 1/8W	1
R939	J707385P910	RES MFILM 1R0 20% 1/8W	1
S901	J708539P1	SWITCH DIP 08-CKT	1
U701	J708786P2	IC DIG GATE 74HC00	1
U702	J708503P2	IC LIN CMPAR LM 339	1
U703	J708786P2	IC DIG GATE 74HC00	1
U704	J707331P3	IC DIG CNTR 4060 CMOS	1
U705	J707242P2	IC DIG FF-D 4013 LOC MOS	1
U801	J708340P1	IC DSP 7720	1
U802	J708872P1	IC CODEX 3054	1
U803	J708789P1	IC DIG FF-D 74HC173	1
U804	J708342P1	IC DIG CNTR 74HC4040	1
U805	A700029P36	IC DIG MUX 4051 CMOS	1
U806	J708165P2	IC LIN OP-AMP 324	1
U807	J708165P2	IC LIN OP-AMP 324	1
U808	J709055P1	IC LIN AF-AMP 1515	1
U809	J708786P3	IC DIG GATE 74HC02	1
U810	J707434P2	IC DIG MUX 4053 CMOS	1
U811	J708789P1	IC DIG FF-D 74HC173	1
U901	J707489P2	IC DIG BUFR 40097 CMOS	1
U903	J707880P3	IC DIG LTH MC 74HC573N	1
U905	J708092P1	IC RAM STAT 2KX8, 25ONS CM	1
U906	J707894P2	IC UP 8-BIT 8031 NMOS	1
U907	J708786P2	IC DIG GATE 74HC00	1
U908	J707331P1	IC DIG CNTR 4017 CMOS	1
U909	J708789P1	IC DIG FF-D 74HC173	1
U910	J708790P3	IC DIG LTH 74HC573 HSCMOS	1
U911	J708787P1	IC DIG DECO 74HC138	1
U912	J708786P2	IC DIG GATE 74HC00	1
U913	J708789P1	IC DIG FF-D 74HC173	1
XF01	J708025P1	HOLDER FUSE 5.OX20.0	1
XF02	J708025P1	HOLDER FUSE 5.OX20.0	1
XU02	J706356P9	SOC IC L-PRF 28 CKT	1

Parts List

COMMON FUNCTION BOARD CF6001 : M905708G1

X404.462

Page No. 5/6

Storno

Storno

Pos.	Code No.	Description	Qt.
XU04	J706356P9	SOC IC L-PRF 28 CKT	1
Y901	J709008P2	CRYSTAL UNIT 11.132MHZ	1
0002	M905709P1R0	BD PW	1
0008	K805742P1	SHIELD	1
0011	J707256P4	COIL FIX	1
0012	J707256P4	COIL FIX	1
0013	J709528P1	BUSHING	1
0014	J709528P1	BUSHING	1

Pos.	Code No.	Description	Qt.

CL6003

CONTROL LOGIC BOARD

The CL6003 is used as the controller in the Control Panel as well as in the Handset Control in the 6000 mobile program. A microprocessor controls all general functions of the CL.

The serial communication between the CL and the main controller in the radiopart is handled by a H-bus (Hybrid bus).

By commands from the keyboard different functions defined by main software in the radio can be controlled. Different information to the user will be displayed on a 16 position dot matrix Vacuum Fluorescent Display and 13 symbols light emitting diodes on the front.

It is possible to insert a code plug device in the control box for service purpose where personality information can be stored.

The backlight is controlled by a light sensitive switch.

The CL6003 is on a single PWB and contains the following circuits:

- Microprocessor
- H-bus interface
- VFD driver unit
- Voltage tripler
- Filament voltage
- Light sensitive switch for backlight
- Backlight
- Symbols drive
- On/off-reset circuit
- H-bus address designation
- Connector system

MICROPROCESSOR

The central part of the control logic is an 8 bit Nmos microprocessor (8051) in a 40 pin dual-in-line package (U200).

The 8051 contains a non-volatile 4k x 8 read-only program memory, a volatile 128 x 8 read/write data memory, 32 I/O lines, and on-chip oscillator.

The clock frequency of the crystal, Y200, driving the microprocessor through pin 18 and 19 is 11.132 MHz.

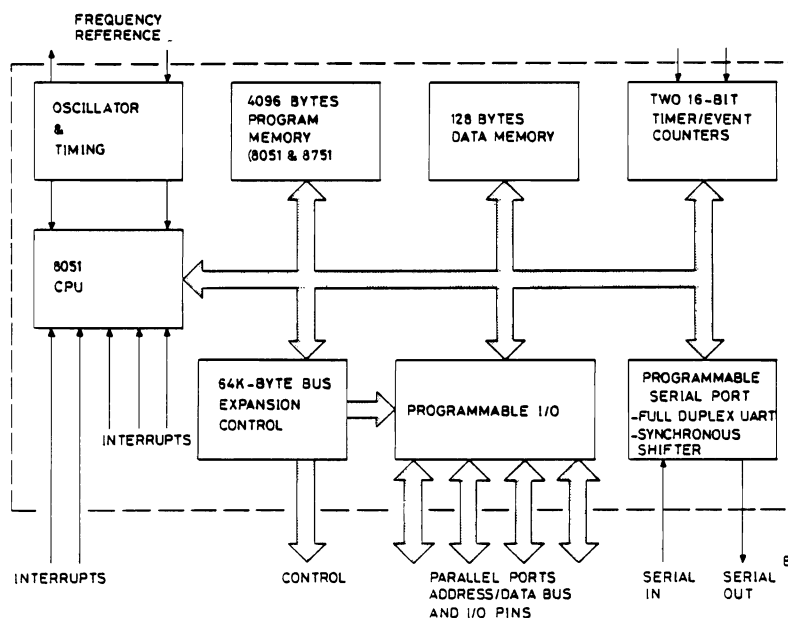

Microprocessor port connections

<u>Name</u>	<u>Port. pin</u>	<u>Function</u>
	P0.0	Backlighting disable
	P0.1	PTT input (low = activated)
	P0.2	Hook switch input (low = off hook)
	P0.3	LED indicator C
	P0.4	LED indicator B
	P0.5	LED indicator 9
	P0.6	LED indicator A
	P0.7	LED indicator 8
	P1.0	Keypad row input 0
	P1.1	Keypad row input 1
	P1.2	Keypad row input 2
	P1.3	Keypad row input 3
	P1.4	EEPROM serial clock
	P1.5	EEPROM serial data
	P1.6	EEPROM CS (chip select/programming handshake)
	P1.7	VFD character (grid) serial clock
	P2.0	LED indicator serial clock
	P2.1	VFD dot serial clock
	P2.2	Keypad column output 0
	P2.3	Keypad column output 1
	P2.4	Keypad column output 2
	P2.5	Keypad column output 3
	P2.6	Keypad column output 4
	P2.7	Keypad column output 5
RXD	P3.0	UART receiver data
TXD	P3.1	UART transmitter data
INT0	P3.2	H-bus DIRECTION line
INT1	P3.3	H-bus SERVICE REQUEST line
	P3.4	H-bus tri-state control
	P3.5	Common serial data output
	P3.6	Mic. enable
	P3.7	LS enable

H-BUS INTERFACE

The on-chip UART on the microprocessor (pin 10-14) is used to handle the serial communication on the H-bus.

The external interface, U201, together with 1 interrupt and 2 control lines constitute the H-bus interface.

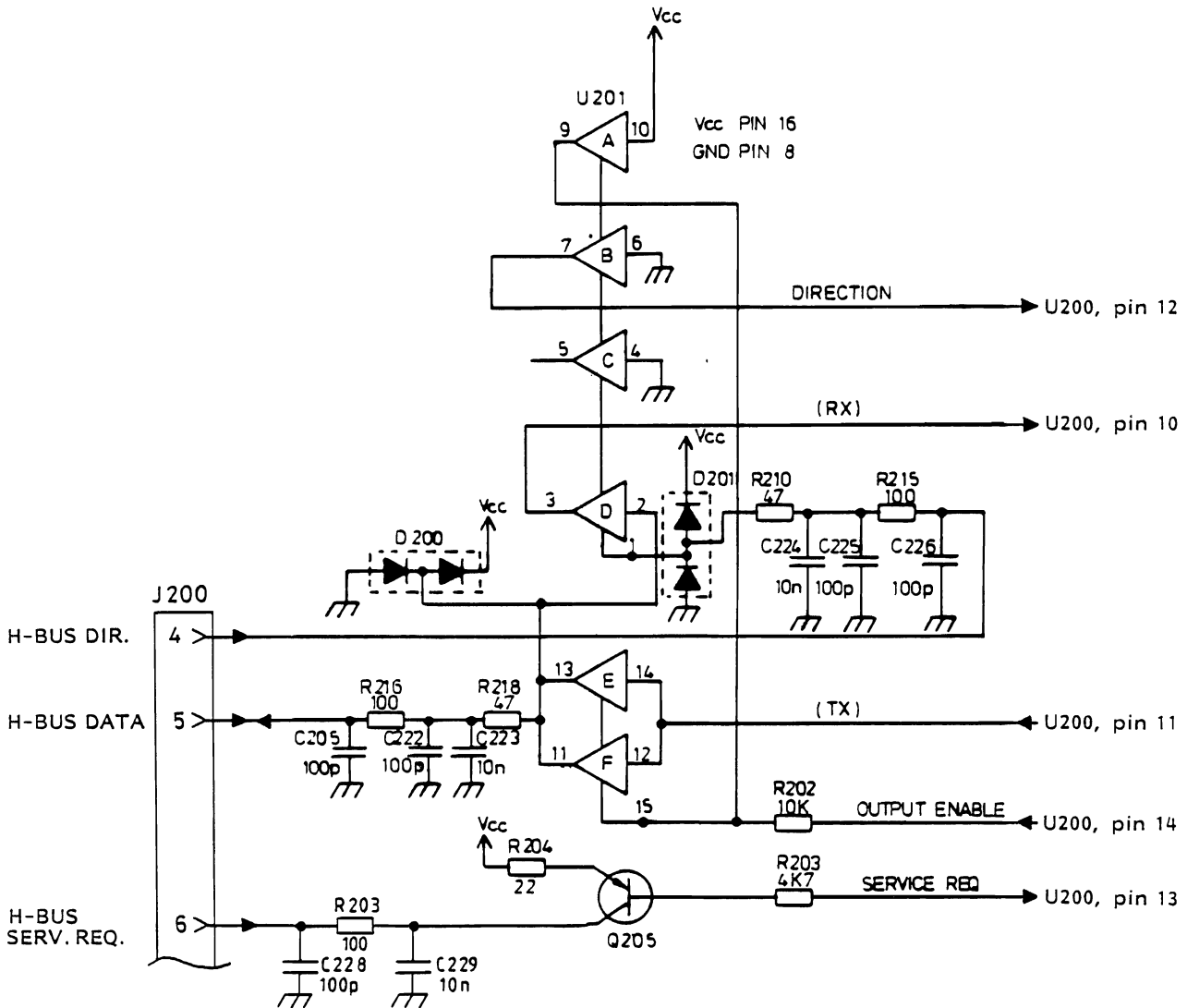

VFD DRIVER UNIT

The Vacuum Flourescent Display driver unit consists of an anode drive unit and a grid drive unit.

To drive the 35 anodes in the 5 x 7 dot-matrix on the display a high voltage display driver has been inserted (U101).

The interface to the microprocessor comprises a serial data line and a serial clock line.

The grid drive consists of two 8 bit shift registers (U205/U206) whose 16 outputs are buffered by 16 transistors to the display grids.

The input data to the two shift registers (pin 7) are controlled by the microprocessor in a serial way.

The shift registers (clocked by a low-to-high transition) are used for driving the character select circuitry. A character is turned "on" by a logical "0" in the corresponding shift register bit.

The first bit clocked into the display driver is dot no. 35 followed by the others in descending order, and the first character loaded into the driver is the leftmost.

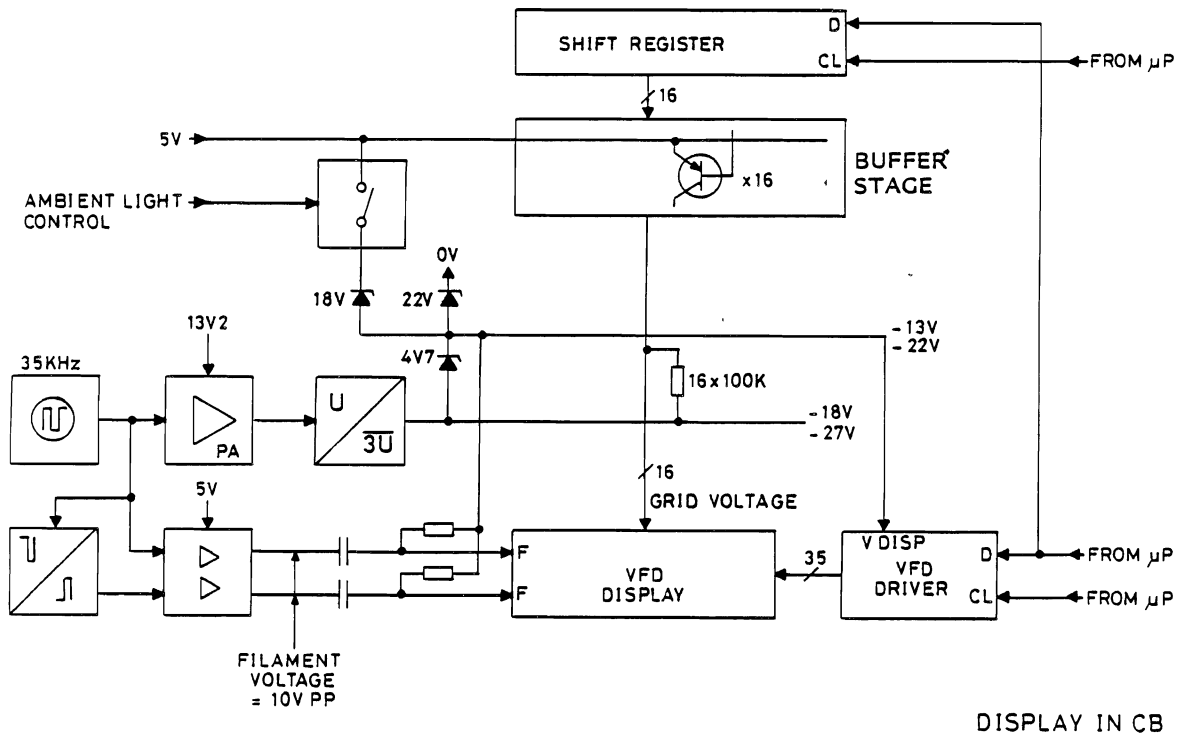

DISPLAY IN CB

VOLTAGE TRIPLER

The purpose of the voltage tripler is to deliver sufficient voltage to the VFD, pins 1 and 33. It consists of an astable multivibrator, U203A, running at a frequency about 35 kHz. The squarewave is amplified and boosted by Q211, Q212, Q213. Then the voltage is tripled by the arrangement around D203, D204, D205. The purpose of D206 is to create cathode bias voltage to the VFD, and D207 stabilizes the display voltage.

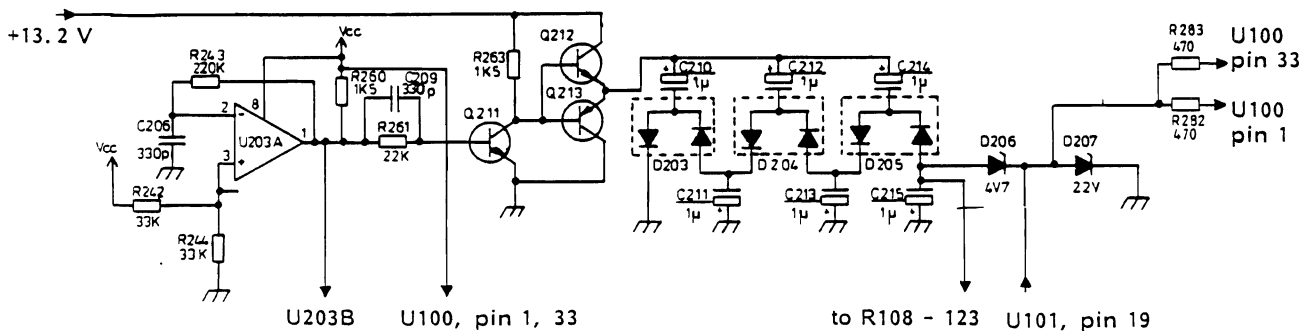

FILAMENT VOLTAGE

The squarewave formed by U203A is amplified by U203B and delivered to a symmetrical booster bridge (Q222, Q223, Q224, Q225). The output from this bridge is "floating" because of the capacitors C220, C221 and supplies the filament on the VFD (pin 1, 33) with a peak-to-peak voltage about -5 V and +5 V.

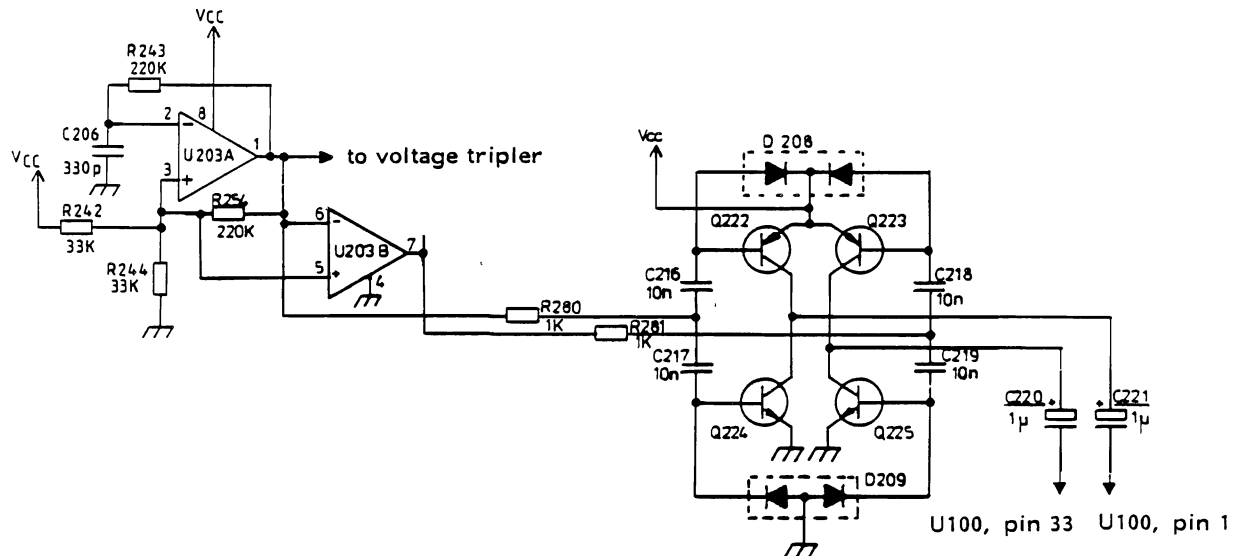

LIGHT SENSITIVE SWITCH FOR BACKLIGHT

This unit consists of a photo transistor (Q200) which is connected to a Schmitt trigger circuit. The purpose of this circuit is to create a well defined threshold level of the light. The Schmitt trigger is made of two inverter gates (U202 D-E). The ratio between R201 and R206 determines the Schmitt trigger level. The output of this Schmitt trigger is delayed by R211 and C204. The purpose of the delay is to prevent flashing of the backlight caused by quick changes in the ambient light. The time constant of this RC network is so determined that the total delay time, from the ambient light changes to the backlight reaction, is about 2 seconds. D210 causes the T. on (backlight on) to be about 0 seconds, but T. off will be 2 seconds.

The following Schmitt trigger is equivalent to the first circuit except that the last gate is replaced by a transistor, Q201, and its purpose being to create a defined shift. It is possible to disable the circuit by putting the emitter of Q201 to a high level from the microprocessor's pin 39. The output is followed by two amplifier stages, Q202-Q203, to switch the light.

The output of Q201 is used by Q226 to dim the VFD display intensity determined by D212. The output of Q202 is used, by the help of Q227/Q228 and D213/D214, to dim the symbol LED's.

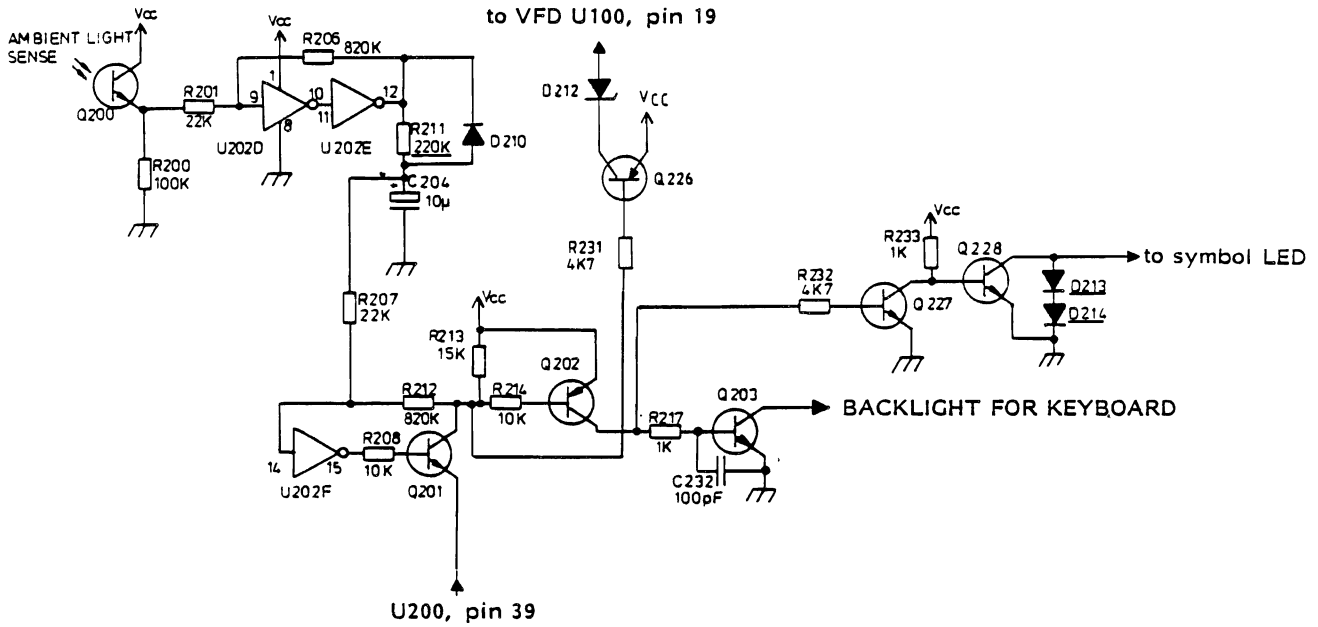

BACKLIGHT

The backlight consists of 24 miniature LED diodes which are placed under the 24 keyboard buttons.

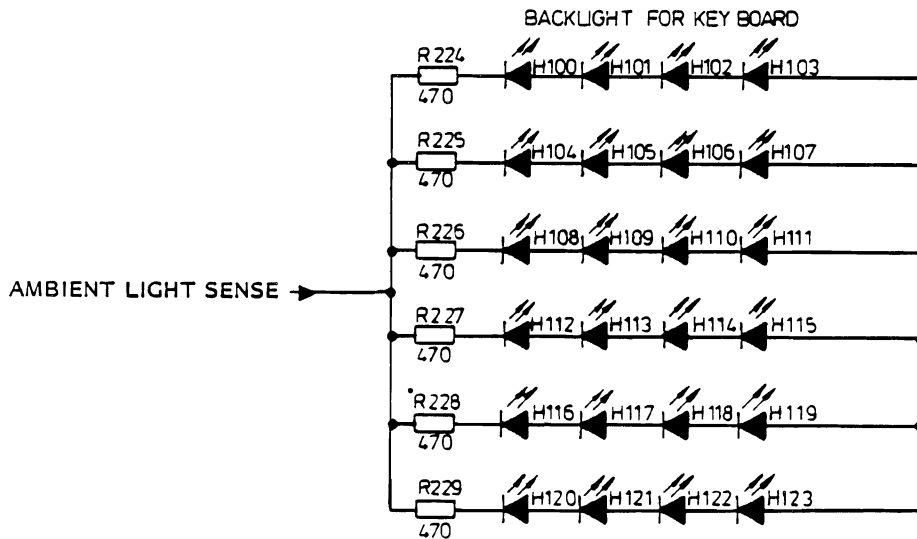

SYMBOLS DRIVE

The CL board contains 13 LED-indicators whose functions are to light up symbols. Eight diodes are connected to a shift register (U204) and buffer stages. A serial data line and serial clock is supplying the shift register with the right information. Another five diodes are connected direct to the microprocessor port 0 pins 3-7 via a buffer stage.

The buffer stages are in all 13 positions a transistor.

When the backlight is turned on a voltage drop about the two diodes D213-D214 causes the supply voltage to all the diodes to decrease thus creating a dimming function on the symbols.

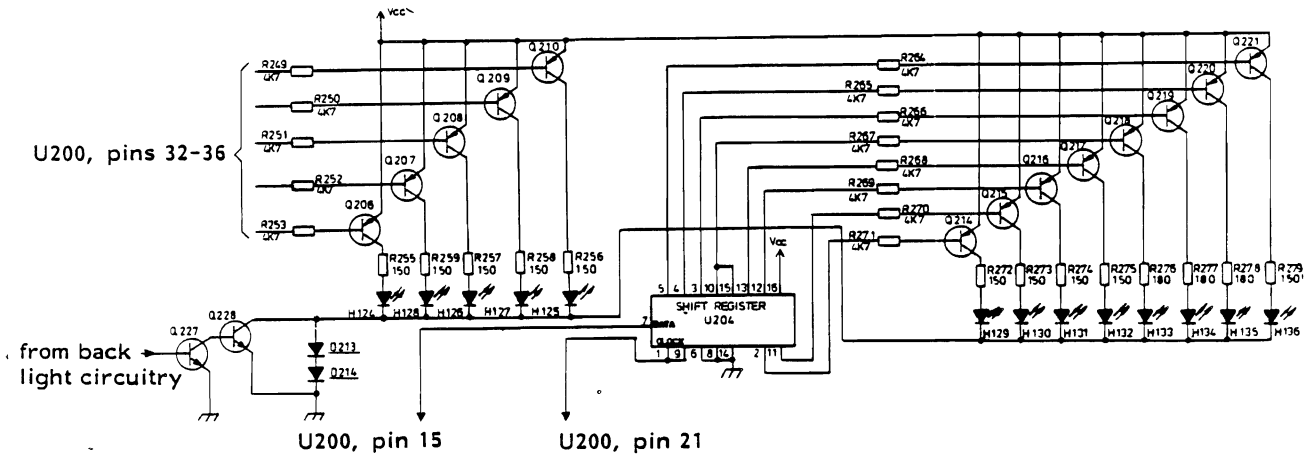

ON/OFF-RESET CIRCUIT

The purpose of the on/off reset circuit is to deliver an on/off pulse to the on/off circuit in the radio part and to reset the microprocessor.

A high pulse from the keyboard switch is regulated by two diodes, D202, to on/off line level (1.2 V). The 1.2 V is going to the on/off circuit on the radio part which turns the +5 V to the CL board on and resets the whole radio.

The reset pulse (+5 V) returns to CL6003 from the radio and turns Q204 on. This resets the microprocessor (pin 9). In the time between the +5 V power supply is going on and the reset pulse is coming, C227 is resetting the microprocessor.

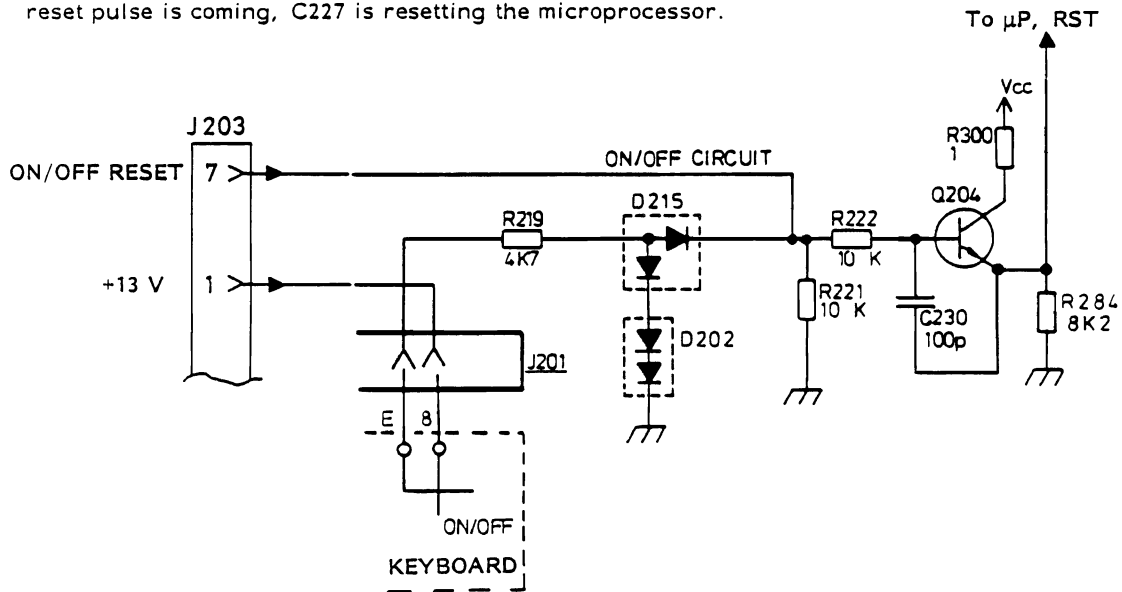

H-BUS ADDRESS DESIGNATION

A diode, D211, between the backlight on/off pin and one of the keyboard pins will determine which of the pre-coded addresses will be used for control box identification. The diode is connected with a strap to the backlight pin. There should be no more than one strap present. It is included that not connecting any strap at all is an address, too. (See addressing instructions, drawing D404.167).

CONNECTOR SYSTEM

All connections to the CL board are made by 3 connectors except in the handset control, where the hook switch is connected into the PWB, pin 37. It is also possible to insert a PTT switch on the board at pin 38.

Below is shown a list of the signals available on the connectors.

J203, Connectors for the radio (remote or local):

On/off reset line

GND

+13.2 V

+5 V

H-bus data, request and direction

J203, RX and TX (audio select)

Mic. enable and LS enable, pins 8 and 9, are 2 control outputs. They are active low, i. e. logical "0" means "on".

1 ohm resistors, R285, R286 are inserted for the handset control only.

J202, Code plug connector

+5 V

GND

Serial data

Serial clock

Chip select

The EEPROM in the (removable) code plug contains 16 x 16 bits. It has a serial interface with a data and a clock line plus a chip select pin, which, during erase and write operations, also acts as a handshake line.

J201, Keyboard connector

A connector where the keyboard foil is inserted

PTT and Hook Switch

These are 2 active low inputs. The bounce time for the switches should be less than 9.0 ms in order to avoid multiple on/off telegrams generated from a single activation.

TECHNICAL SPECIFICATIONS

ELECTRICAL

The C1 PWB is supplied from the radio with two voltages.

Supply voltage 1

10.8-15.6 V DC (13.2 V nom.)

Current drain 1

170 mA (Backlight off)

Supply voltage 2

+5 V \pm 5%

Current drain 2

250 mA (Symbols off)

NOTE:

Every symbol LED is drawing about 20 mA each on the +5 V supply.

H-BUS CONTROL SIGNALS

Maximum input

Lo voltage: (1.0 V)

Minimum input

Hi voltage: (3.2 V)

Maximum outputs

Lo voltage: (0.4 V)

OUTPUT

On/off signal: J203 pin 7 (active High)

Hi voltage >1.2 V

Lo voltage <0.2 V

Audio select: (active Low)

Mic. enable J203 pin 8 <0.2 V

LS enable J203 pin 9 <0.2 V

(These signals are only present in the handset control)

INPUT

Hook Switch for handset control version

Connecting H12 to GND: handset on hook

PTT

Connecting H13 to GND: PTT on (active Lo)

ENVIRONMENTAL

Temperature range

Operation -25°C to +60°C

Storage -40°C to +70°C

Mechanical dimensions

Length x Width x Height: 184 x 57 x 28

Weight

280 g

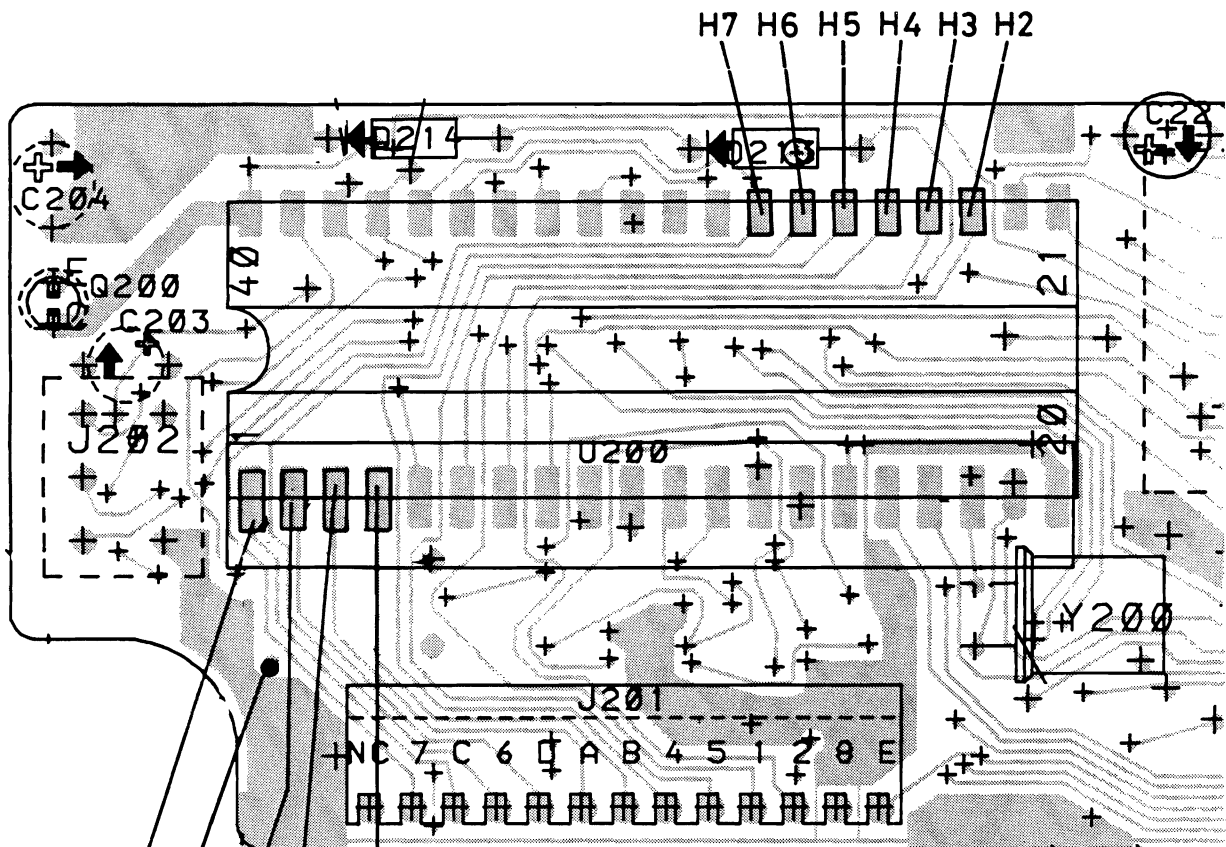

H8 H1 H9 H10 H11
IN THE SAME INSTALLATION:

- ONE BOX AT LEAST MUST HAVE ADDR. 20H, WHICH MEANS NO STRAP.
- TWO BOXES MUST NOT HAVE THE SAME ADDRESS.

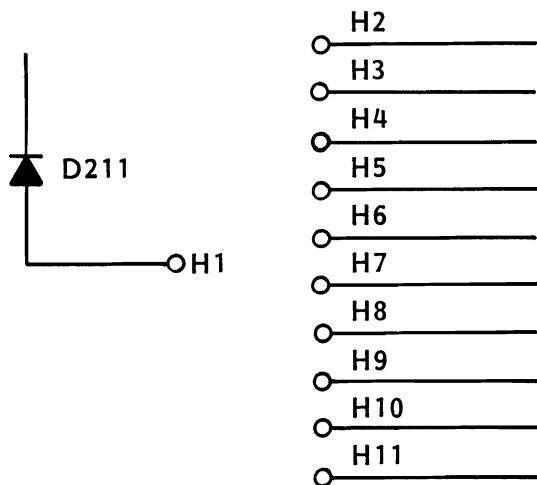

WHEN THE CONTROL HEAD IS USED AS SERVICE INSTRUMENT CONNECT H1 TO H2.

CB ADDRESS	H-BUS ADDRESS
NO STRAP	20H
H2	21H
H3	22H
H4	23H
H5	24H
H6	25H
H7	26H
H8	27H
H9	28H
H10	29H
H11	2AH

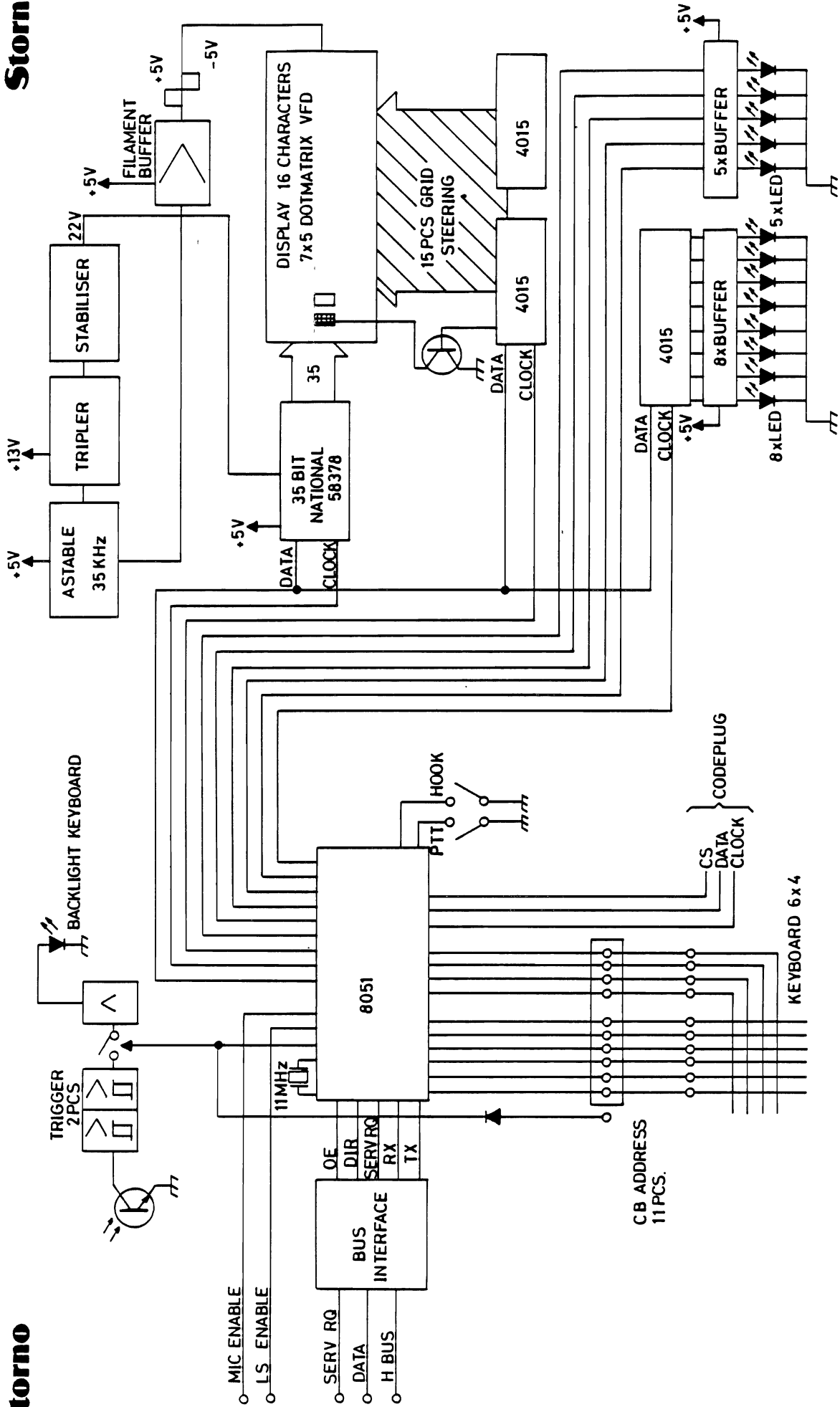

BLOCK DIAGRAM CL6003

D404.032

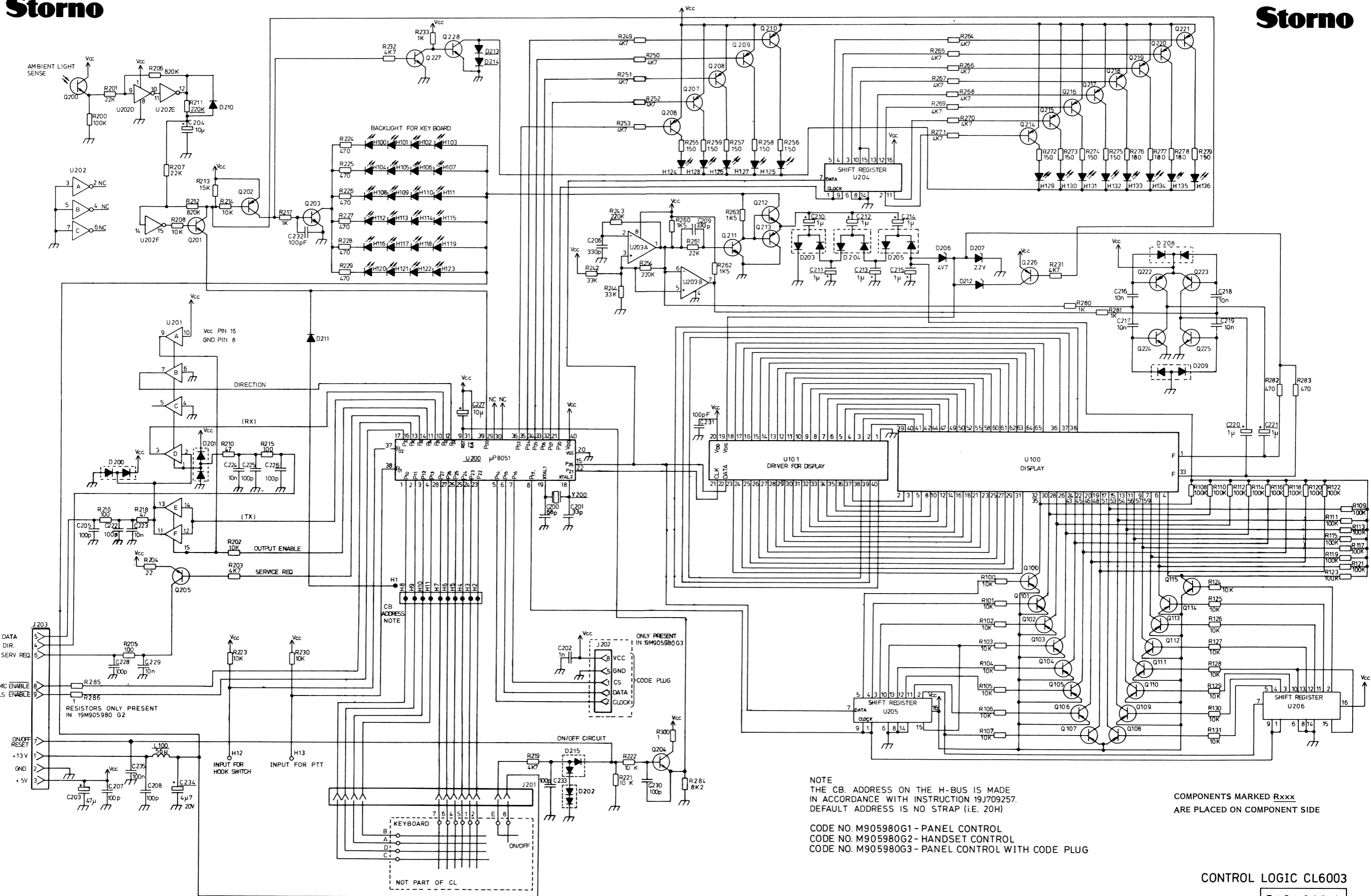

NOTE
 THE CB. ADDRESS ON THE H-BUS IS MADE
 IN ACCORDANCE WITH INSTRUCTION 19J709257.
 DEFAULT ADDRESS IS NO STRAP (I.E. 20H)

CODE NO. M905980G1 - PANEL CONTROL
 CODE NO. M905980G2 - HANDSET CONTROL
 CODE NO. M905980G3 - PANEL CONTROL WITH CODE PLUG

COMPONENTS MARKED Rxxx
 ARE PLACED ON COMPONENT SIDE

CONTROL LOGIC CL6003

D404.036/2

Storno

Storno

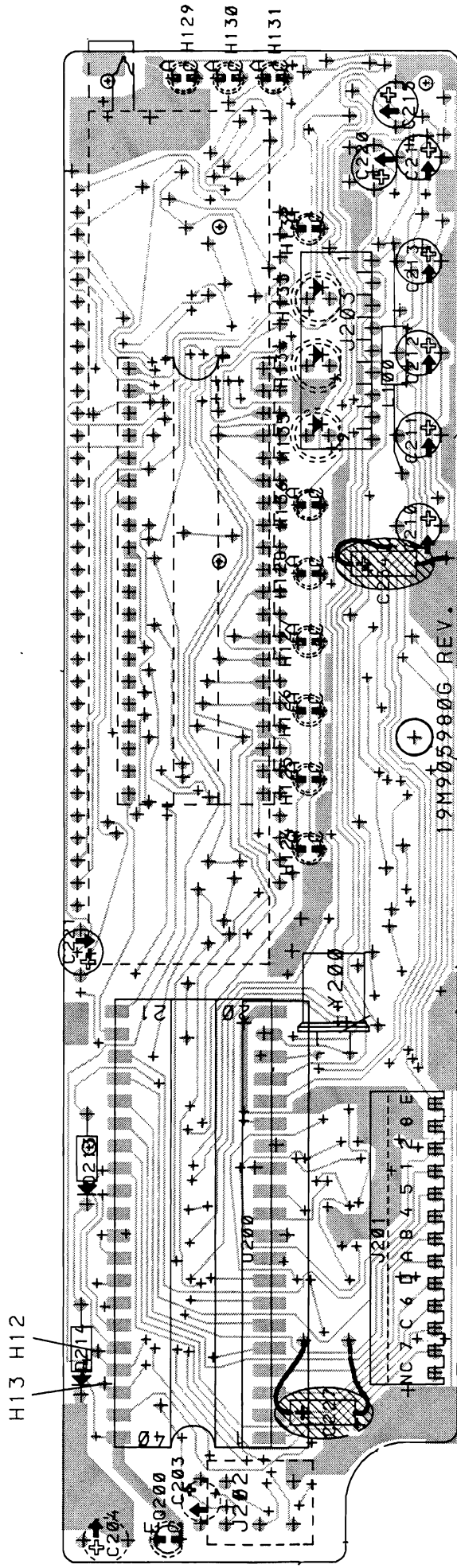

- CODE NO. M905980G1 - PANEL CONTROL
- CODE NO. M905980G2 - HANDSET CONTROL
- CODE NO. M905980G3 - PANEL CONTROL WITH CODE PLUG

CONTROL LOGIC CL6003
COMPONENT LAYOUT - COMPONENT SIDE

D404.158

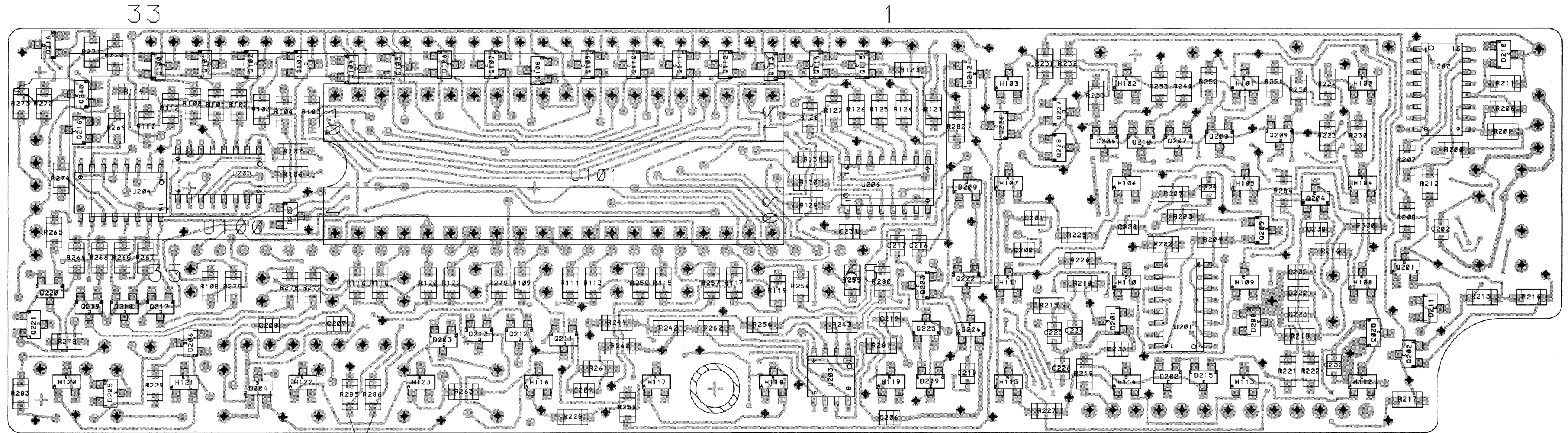

R285, R286 ONLY
PRESENT IN G2.

CODE NO. M905980G1 - PANEL CONTROL

CODE NO. M905980G2 - HANDSET CONTROL

CODE NO. M905980G3 - PANEL CONTROL WITH CODE PLUG

CONTROL LOGIC CL6003
COMPONENT LAYOUT - CHIP SIDE

D404.159

ITEM NUMBER	DESCRIPTION
M905980G1	CL 6003, FOR PANEL CONTROL
M905980G2	CL 6003, F. HANDSET CONTROL, W. HOOK-SW.
M905980G3	CL 6003, F. PANEL CONTROL, WITH CODE-PLUG
=====	
J709394G1	SUB ASM.: U200,- U-PROC., PROGRAMMED-

P A R T S L I S T :

CIRCUIT POSITION	COMPONENT ITEM NUMBER	COMPONENT DESCRIPTION	QUANTITY	
C200	J707436P53	CAP CER NPO 68P 5% 50V	1	ALL
C201	J707436P37	CAP CER NPO 33P 5% 50V	1	ALL
C202	J707438P5	CAP CER CL2 1N 10% 50V	1	ALL
C203	J707444P17	CAP TA SOL 47U 20% 10V	1	ALL
C204	J707444P7	CAP TA SOL 10U 20% 16V	1	ALL
C205	J707436P61	CAP CER NPO 100P 5% 50V	1	ALL
C206	J707438P2	CAP CER CL2 330P 10% 50V	1	ALL
C207	J707436P61	CAP CER NPO 100P 5% 50V	1	ALL
C208	J707436P61	CAP CER NPO 100P 5% 50V	1	ALL
C209	J707438P2	CAP CER CL2 330P 10% 50V	1	ALL
C210	J707444P4	CAP TA SOL 1U 20% 35V	1	ALL
C211	J707444P4	CAP TA SOL 1U 20% 35V	1	ALL
C212	J707444P4	CAP TA SOL 1U 20% 35V	1	ALL
C213	J707444P4	CAP TA SOL 1U 20% 35V	1	ALL
C214	J707444P4	CAP TA SOL 1U 20% 35V	1	ALL
C215	J707444P4	CAP TA SOL 1U 20% 35V	1	ALL
C216	J707438P14	CAP CER CL2 10N 10% 50V	1	ALL
C217	J707438P14	CAP CER CL2 10N 10% 50V	1	ALL
C218	J707438P14	CAP CER CL2 10N 10% 50V	1	ALL
C219	J707438P14	CAP CER CL2 10N 10% 50V	1	ALL
C220	J707444P4	CAP TA SOL 1U 20% 35V	1	ALL
C221	J707444P4	CAP TA SOL 1U 20% 35V	1	ALL
C222	J707436P61	CAP CER NPO 100P 5% 50V	1	ALL
C223	J707438P14	CAP CER CL2 10N 10% 50V	1	ALL
C224	J707438P14	CAP CER CL2 10N 10% 50V	1	ALL
C225	J707436P61	CAP CER NPO 100P 5% 50V	1	ALL
C226	J707436P61	CAP CER NPO 100P 5% 50V	1	ALL
C227	B800650P16	CAP TA SOL 10U 20% 10V	1	ALL
C228	J707436P61	CAP CER NPO 100P 5% 50V	1	ALL
C229	J707438P14	CAP CER CL2 10N 10% 50V	1	ALL
C230	J707436P61	CAP CER NPO 100P 5% 50V	1	ALL
C231	J707436P61	CAP CER NPO 100P 5% 50V	1	ALL
C232	J707436P61	CAP CER NPO 100P 5% 50V	1	ALL
C233	J707436P61	CAP CER NPO 100P 5% 50V	1	ALL
C234	B800650P28	CAP TA SOL 4U7 10% 20V	1	ALL
C235	J707438P26	CAP CER CL2 100N 10% 50V	1	ALL
D200	J707389P1	DIO SI SIG BAV 99	1	ALL
D201	J707389P1	DIO SI SIG BAV 99	1	ALL

CIRCUIT POSITION	COMPONENT ITEM NUMBER	COMPONENT DESCRIPTION	QUANTITY	
D202	J707389P1	DIO SI SIG BAV 99	1	ALL
D203	J707389P1	DIO SI SIG BAV 99	1	ALL
D204	J707389P1	DIO SI SIG BAV 99	1	ALL
D205	J707389P1	DIO SI SIG BAV 99	1	ALL
D206	J707459P1	DIO SI ZENR 4V7 5% 0,2W	1	ALL
D207	J707459P9	DIO SI ZENR 22V 5% 0,2W	1	ALL
D208	J707390P1	DIO SI SIG BAV 74	1	ALL
D209	J708681P1	DIO SI SIG BAW 56	1	ALL
D210	J707389P1	DIO SI SIG BAV 99	1	ALL
D211	J707389P1	DIO SI SIG BAV 99	1	ALL
D212	J707459P9	DIO SI ZENR 22V 5% 0,2W	1	ALL
D213	J709122P1	DIO SI SIG 1N4150	1	ALL
D214	J709122P1	DIO SI SIG 1N4150	1	ALL
D215	J708681P1	DIO SI SIG BAW 56	1	ALL
H100	J708405P1	DIO OPTO ELEC GREEN, CQV 233	1	ALL
H101	J708405P1	DIO OPTO ELEC GREEN, CQV 233	1	ALL
H102	J708405P1	DIO OPTO ELEC GREEN, CQV 233	1	ALL
H103	J708405P1	DIO OPTO ELEC GREEN, CQV 233	1	ALL
H104	J708405P1	DIO OPTO ELEC GREEN, CQV 233	1	ALL
H105	J708405P1	DIO OPTO ELEC GREEN, CQV 233	1	ALL
H106	J708405P1	DIO OPTO ELEC GREEN, CQV 233	1	ALL
H107	J708405P1	DIO OPTO ELEC GREEN, CQV 233	1	ALL
H108	J708405P1	DIO OPTO ELEC GREEN, CQV 233	1	ALL
H109	J708405P1	DIO OPTO ELEC GREEN, CQV 233	1	ALL
H110	J708405P1	DIO OPTO ELEC GREEN, CQV 233	1	ALL
H111	J708405P1	DIO OPTO ELEC GREEN, CQV 233	1	ALL
H112	J708405P1	DIO OPTO ELEC GREEN, CQV 233	1	ALL
H113	J708405P1	DIO OPTO ELEC GREEN, CQV 233	1	ALL
H114	J708405P1	DIO OPTO ELEC GREEN, CQV 233	1	ALL
H115	J708405P1	DIO OPTO ELEC GREEN, CQV 233	1	ALL
H116	J708405P1	DIO OPTO ELEC GREEN, CQV 233	1	ALL
H117	J708405P1	DIO OPTO ELEC GREEN, CQV 233	1	ALL
H118	J708405P1	DIO OPTO ELEC GREEN, CQV 233	1	ALL
H119	J708405P1	DIO OPTO ELEC GREEN, CQV 233	1	ALL
H120	J708405P1	DIO OPTO ELEC GREEN, CQV 233	1	ALL
H121	J708405P1	DIO OPTO ELEC GREEN, CQV 233	1	ALL
H122	J708405P1	DIO OPTO ELEC GREEN, CQV 233	1	ALL
H123	J708405P1	DIO OPTO ELEC GREEN, CQV 233	1	ALL
H124	J708000P7	* DIO OPTO ELEC YELL.,LG3130-L	1	ALL
H125	J708000P7	* DIO OPTO ELEC YELL.,LG3130-L	1	ALL
H126	J708000P7	* DIO OPTO ELEC YELL.,LG3130-L	1	ALL
H127	J708000P7	* DIO OPTO ELEC YELL.,LG3130-L	1	ALL
H128	J708000P6	* DIO OPTO ELEC YELL.,LY3140-L	1	ALL
H129	J708000P7	* DIO OPTO ELEC YELL.,LG3130-L	1	ALL
H130	J708000P7	* DIO OPTO ELEC YELL.,LG3130-L	1	ALL
H131	J708000P7	* DIO OPTO ELEC YELL.,LG3130-L	1	ALL
H132	J708000P7	* DIO OPTO ELEC YELL.,LG3130-L	1	ALL
H133	J709312P3	DIO OPTO, YELL., HLMP-3850	1	ALL
H134	J709312P2	DIO OPTO, GREEN, HLMP-3950	1	ALL
H135	J709312P1	DIO OPTO, RED, HLMP-3750	1	ALL
H136	J708000P7	* DIO OPTO ELEC YELL.,LG3130-L	1	ALL

CONT.D ON NEXT PAGE: PAGE 3

CIRCUIT POSITION	COMPONENT ITEM NUMBER	COMPONENT DESCRIPTION	QUANTITY	
J201	J708541P13	CONN PWB FEMALE 13-WAY	1	ALL
J202	M906043P1	CONNECTOR HOUSING, FEMALE	1	F.:-G3
J203	J708776G1	CONNECTOR MODIFIED	1	ALL
L100	A700024P34	* COIL RF FIX 56UH 10%	1	ALL
Q100	J707387P1	TSTR PNP SI BCW 30	1	ALL
Q101	J707387P1	TSTR PNP SI BCW 30	1	ALL
Q102	J707387P1	TSTR PNP SI BCW 30	1	ALL
Q103	J707387P1	TSTR PNP SI BCW 30	1	ALL
Q104	J707387P1	TSTR PNP SI BCW 30	1	ALL
Q105	J707387P1	TSTR PNP SI BCW 30	1	ALL
Q106	J707387P1	TSTR PNP SI BCW 30	1	ALL
Q107	J707387P1	TSTR PNP SI BCW 30	1	ALL
Q108	J707387P1	TSTR PNP SI BCW 30	1	ALL
Q109	J707387P1	TSTR PNP SI BCW 30	1	ALL
Q110	J707387P1	TSTR PNP SI BCW 30	1	ALL
Q111	J707387P1	TSTR PNP SI BCW 30	1	ALL
Q112	J707387P1	TSTR PNP SI BCW 30	1	ALL
Q113	J707387P1	TSTR PNP SI BCW 30	1	ALL
Q114	J707387P1	TSTR PNP SI BCW 30	1	ALL
Q115	J707387P1	TSTR PNP SI BCW 30	1	ALL
Q200	J708525P1	TSTR OPTO SFH 309	1	ALL
Q201	J707386P1	TSTR NPN SI BCW 32	1	ALL
Q202	J707387P1	TSTR PNP SI BCW 30	1	ALL
Q203	J707429P1	TSTR NPN SI BCX 20	1	ALL
Q204	J707386P1	TSTR NPN SI BCW 32	1	ALL
Q205	J707387P1	TSTR PNP SI BCW 30	1	ALL
Q206	J707387P1	TSTR PNP SI BCW 30	1	ALL
Q207	J707387P1	TSTR PNP SI BCW 30	1	ALL
Q208	J707387P1	TSTR PNP SI BCW 30	1	ALL
Q209	J707387P1	TSTR PNP SI BCW 30	1	ALL
Q210	J707387P1	TSTR PNP SI BCW 30	1	ALL
Q211	J707386P1	TSTR NPN SI BCW 32	1	ALL
Q212	J707386P1	TSTR NPN SI BCW 32	1	ALL
Q213	J707387P1	TSTR PNP SI BCW 30	1	ALL
Q214	J707387P1	TSTR PNP SI BCW 30	1	ALL
Q215	J707387P1	TSTR PNP SI BCW 30	1	ALL
Q216	J707387P1	TSTR PNP SI BCW 30	1	ALL
Q217	J707387P1	TSTR PNP SI BCW 30	1	ALL
Q218	J707387P1	TSTR PNP SI BCW 30	1	ALL
Q219	J707387P1	TSTR PNP SI BCW 30	1	ALL
Q220	J707387P1	TSTR PNP SI BCW 30	1	ALL
Q221	J707387P1	TSTR PNP SI BCW 30	1	ALL
Q222	J707387P1	TSTR PNP SI BCW 30	1	ALL
Q223	J707387P1	TSTR PNP SI BCW 30	1	ALL
Q224	J707386P1	TSTR NPN SI BCW 32	1	ALL
Q225	J707386P1	TSTR NPN SI BCW 32	1	ALL
Q226	J707387P1	TSTR PNP SI BCW 30	1	ALL
Q227	J707386P1	TSTR NPN SI BCW 32	1	ALL
Q228	J707429P1	TSTR NPN SI BCX 20	1	ALL
R100	J707385P103	RES MFILM 10K 5% 1/8W	1	ALL
R101	J707385P103	RES MFILM 10K 5% 1/8W	1	ALL

CIRCUIT POSITION	COMPONENT ITEM NUMBER	COMPONENT DESCRIPTION	QUANTITY	
R102	J707385P103	RES MFILM 10K 5% 1/8W	1	ALL
R103	J707385P103	RES MFILM 10K 5% 1/8W	1	ALL
R104	J707385P103	RES MFILM 10K 5% 1/8W	1	ALL
R105	J707385P103	RES MFILM 10K 5% 1/8W	1	ALL
R106	J707385P103	RES MFILM 10K 5% 1/8W	1	ALL
R107	J707385P103	RES MFILM 10K 5% 1/8W	1	ALL
R108	J707385P104	RES MFILM 100K 5% 1/8W	1	ALL
R109	J707385P104	RES MFILM 100K 5% 1/8W	1	ALL
R110	J707385P104	RES MFILM 100K 5% 1/8W	1	ALL
R111	J707385P104	RES MFILM 100K 5% 1/8W	1	ALL
R112	J707385P104	RES MFILM 100K 5% 1/8W	1	ALL
R113	J707385P104	RES MFILM 100K 5% 1/8W	1	ALL
R114	J707385P104	RES MFILM 100K 5% 1/8W	1	ALL
R115	J707385P104	RES MFILM 100K 5% 1/8W	1	ALL
R116	J707385P104	RES MFILM 100K 5% 1/8W	1	ALL
R117	J707385P104	RES MFILM 100K 5% 1/8W	1	ALL
R118	J707385P104	RES MFILM 100K 5% 1/8W	1	ALL
R119	J707385P104	RES MFILM 100K 5% 1/8W	1	ALL
R120	J707385P104	RES MFILM 100K 5% 1/8W	1	ALL
R121	J707385P104	RES MFILM 100K 5% 1/8W	1	ALL
R122	J707385P104	RES MFILM 100K 5% 1/8W	1	ALL
R123	J707385P104	RES MFILM 100K 5% 1/8W	1	ALL
R124	J707385P103	RES MFILM 10K 5% 1/8W	1	ALL
R125	J707385P103	RES MFILM 10K 5% 1/8W	1	ALL
R126	J707385P103	RES MFILM 10K 5% 1/8W	1	ALL
R127	J707385P103	RES MFILM 10K 5% 1/8W	1	ALL
R128	J707385P103	RES MFILM 10K 5% 1/8W	1	ALL
R129	J707385P103	RES MFILM 10K 5% 1/8W	1	ALL
R130	J707385P103	RES MFILM 10K 5% 1/8W	1	ALL
R131	J707385P103	RES MFILM 10K 5% 1/8W	1	ALL
R200	J707385P104	RES MFILM 100K 5% 1/8W	1	ALL
R201	J707385P223	RES MFILM 22K 5% 1/8W	1	ALL
R202	J707385P103	RES MFILM 10K 5% 1/8W	1	ALL
R203	J707385P472	RES MFILM 4K7 5% 1/8W	1	ALL
R204	J707385P220	RES MFILM 22R 5% 1/8W	1	ALL
R205	J707385P101	RES MFILM 100R 5% 1/8W	1	ALL
R206	J707385P824	RES MFILM 820K 5% 1/8W	1	ALL
R207	J707385P223	RES MFILM 22K 5% 1/8W	1	ALL
R208	J707385P103	RES MFILM 10K 5% 1/8W	1	ALL
R210	J707385P470	RES MFILM 47R 5% 1/8W	1	ALL
R211	J707385P224	RES MFILM 220K 5% 1/8W	1	ALL
R212	J707385P824	RES MFILM 820K 5% 1/8W	1	ALL
R213	J707385P153	RES MFILM 15K 5% 1/8W	1	ALL
R214	J707385P103	RES MFILM 10K 5% 1/8W	1	ALL
R215	J707385P101	RES MFILM 100R 5% 1/8W	1	ALL
R216	J707385P101	RES MFILM 100R 5% 1/8W	1	ALL
R217	J707385P102	RES MFILM 1K0 5% 1/8W	1	ALL
R218	J707385P470	RES MFILM 47R 5% 1/8W	1	ALL
R219	J707385P472	RES MFILM 4K7 5% 1/8W	1	ALL
R221	J707385P103	RES MFILM 10K 5% 1/8W	1	ALL
R222	J707385P103	RES MFILM 10K 5% 1/8W	1	ALL
R223	J707385P124 * *	RES MFILM 120K 5% 1/8W	1	ALL
R224	J707385P471	RES MFILM 470R 5% 1/8W	1	ALL

CIRCUIT POSITION	COMPONENT ITEM NUMBER	COMPONENT DESCRIPTION	QUANTITY	
R225	J707385P471	RES MFILM 470R 5% 1/8W	1	ALL
R226	J707385P471	RES MFILM 470R 5% 1/8W	1	ALL
R227	J707385P471	RES MFILM 470R 5% 1/8W	1	ALL
R228	J707385P471	RES MFILM 470R 5% 1/8W	1	ALL
R229	J707385P471	RES MFILM 470R 5% 1/8W	1	ALL
R230	J707385P124 * *	RES MFILM 120K 5% 1/8W	1	ALL
R231	J707385P472	RES MFILM 4K7 5% 1/8W	1	ALL
R232	J707385P472	RES MFILM 4K7 5% 1/8W	1	ALL
R233	J707385P102	RES MFILM 1K0 5% 1/8W	1	ALL
R242	J707385P333	RES MFILM 33K 5% 1/8W	1	ALL
R243	J707385P224	RES MFILM 220K 5% 1/8W	1	ALL
R244	J707385P333	RES MFILM 33K 5% 1/8W	1	ALL
R249	J707385P472	RES MFILM 4K7 5% 1/8W	1	ALL
R250	J707385P472	RES MFILM 4K7 5% 1/8W	1	ALL
R251	J707385P472	RES MFILM 4K7 5% 1/8W	1	ALL
R252	J707385P472	RES MFILM 4K7 5% 1/8W	1	ALL
R253	J707385P472	RES MFILM 4K7 5% 1/8W	1	ALL
R254	J707385P224	RES MFILM 220K 5% 1/8W	1	ALL
R255	J707385P151	RES MFILM 150R 5% 1/8W	1	ALL
R256	J707385P151	RES MFILM 150R 5% 1/8W	1	ALL
R257	J707385P151	RES MFILM 150R 5% 1/8W	1	ALL
R258	J707385P151	RES MFILM 150R 5% 1/8W	1	ALL
R259	J707385P151	RES MFILM 150R 5% 1/8W	1	ALL
R260	J707385P152	RES MFILM 1K5 5% 1/8W	1	ALL
R261	J707385P223	RES MFILM 22K 5% 1/8W	1	ALL
R262	J707385P152	RES MFILM 1K5 5% 1/8W	1	ALL
R263	J707385P152	RES MFILM 1K5 5% 1/8W	1	ALL
R264	J707385P472	RES MFILM 4K7 5% 1/8W	1	ALL
R265	J707385P472	RES MFILM 4K7 5% 1/8W	1	ALL
R266	J707385P472	RES MFILM 4K7 5% 1/8W	1	ALL
R267	J707385P472	RES MFILM 4K7 5% 1/8W	1	ALL
R268	J707385P472	RES MFILM 4K7 5% 1/8W	1	ALL
R269	J707385P472	RES MFILM 4K7 5% 1/8W	1	ALL
R270	J707385P472	RES MFILM 4K7 5% 1/8W	1	ALL
R271	J707385P472	RES MFILM 4K7 5% 1/8W	1	ALL
R272	J707385P151	RES MFILM 150R 5% 1/8W	1	ALL
R273	J707385P151	RES MFILM 150R 5% 1/8W	1	ALL
R274	J707385P151	RES MFILM 150R 5% 1/8W	1	ALL
R275	J707385P151	RES MFILM 150R 5% 1/8W	1	ALL
R276	J707385P181	RES MFILM 180R 5% 1/8W	1	ALL
R277	J707385P181	RES MFILM 180R 5% 1/8W	1	ALL
R278	J707385P181	RES MFILM 180R 5% 1/8W	1	ALL
R279	J707385P151	RES MFILM 150R 5% 1/8W	1	ALL
R280	J707385P102	RES MFILM 1K0 5% 1/8W	1	ALL
R281	J707385P102	RES MFILM 1K0 5% 1/8W	1	ALL
R282	J707385P471	RES MFILM 470R 5% 1/8W	1	ALL
R283	J707385P471	RES MFILM 470R 5% 1/8W	1	ALL
R284	J707385P822	RES MFILM 8K2 5% 1/8W	1	ALL
R285	J707385P910	RES MFILM 1R0 20% 1/8W	1	F.:-G2
R286	J707385P910	RES MFILM 1R0 20% 1/8W	1	F.:-G2
R300	J707385P910	RES MFILM 1R0 20% 1/8W	1	ALL

CONT.D ON NEXT PAGE: PAGE 6

CIRCUIT POSITION	COMPONENT ITEM NUMBER	COMPONENT DESCRIPTION	QUANTITY	
U100	J708896P1	DISPLAY, FLOURESC.-, 16-SD-01Z	1	ALL
U101	J708897P1	IC DRV VFD 58348	1	ALL
U200	J709394G1	INT CKT., U-PROC., PRGRMD.-	1	(SEE BELOW)
U201	J708791P1	IC, DIG BUFR 74HC367, HSCMOS	1	ALL
U202	J708356P1	IC, DIG BUFR 4049, CMOS	1	ALL
U203	J708503P3	IC, LIN CMPAR LM 293	1	ALL
U204	J709016P1	IC, DIG REG HC4015, HSCMOS	1	ALL
U205	J709016P1	IC, DIG REG HC4015, HSCMOS	1	ALL
U206	J709016P1	IC, DIG REG HC4015, HSCMOS	1	ALL
Y200	J709008P2	CRYSTAL UNIT 11.132MHZ	1	ALL
0002	M9-----P1R1	BD PW., REVISION NO.1	(1)	ALL
0008	A702455P1	NUT, SELF CLINCHING	1	
0009	J707938P2	TAPE, NPR 0.8X6.35	0.006	M
0010	M906060P1	LIGHT SEPARATOR	1	
0011	J709373G1	SHIELD ASM	1	
0013	J708296P3	SLV INS ELEC PTFE CL R	0.016	M
0017	J706922P6	TAPE PRESSURE SENSITIVE	0.06	M
0018	J708296P3	SLEEV., INSUL.-, ELEC PTFE CL	0.012	M
0019	J708296P3	SLEEV., INSUL.-, ELEC PTFE CL	0.018	M
0020	J708413P2	SLV SIL RUBB. NAT.	0.006	M

U200 :	J709394G1 :	IC, MODIF. BY PROGRAMM. :		

0002	J707894P3	IC, U-PROC., 8-BIT, C8051H NMOS	1	

AA6001

AUDIO AMPLIFIER

The AA6001 is the microphone board in the handset used with NMT 6000 and CQM6000.

The board is part of the connections between the retainer and the volume control board AA6002, and contains decoupling capacitors.

The reed relay for the hook switch is mounted on this board.

The AA6001 contains two functions:

- Microphone amplifier.
- Microphone mute circuit.

The microphone mute circuit mutes the signal depending on the voltage at MIC MUTE.

CIRCUIT DESCRIPTION

The power supply as well as the signal are fed through the same line HS MIC. This line is, connected to a supply voltage of 8 V through a 680 ohm resistor, R544, on the common function board CF6002.

When the microphone is unmuted the DC voltage at HS MIC is approx. 4 V. This DC stabilization depends on the voltage level at the base of Q101, and the voltage drop across R105.

The voltage at the base of Q101 depends on the

resistor R101-104, and the DC resistance in the microphone.

The voltage drop across R105 depends on the value of R106.

The microphone requires a DC voltage between 1.1-10 V because there is an amplifier in the microphone.

The gain depends on R105 and R107.

The amplifier is unmuted when Q103 is saturated. R108, R109 and C118 prevent the DC voltage on HS MIC from jumping when the MIC MUTE changes. The amplifier is muted when Q104 is saturated.

SPECIFICATIONS

INTERFACE

HS MIC

100 mV

PTT

LOW: 0 V

HIGH: no connection

MIC MUTE

LOW: <0.5 V

HIGH (muted): >3 V

Power supply

8 V

Consumption

<10 mA

Temperature range

-25°C to +55°C

Dimensions

L x W x H: 42 mm x 32.5 mm x 1 mm

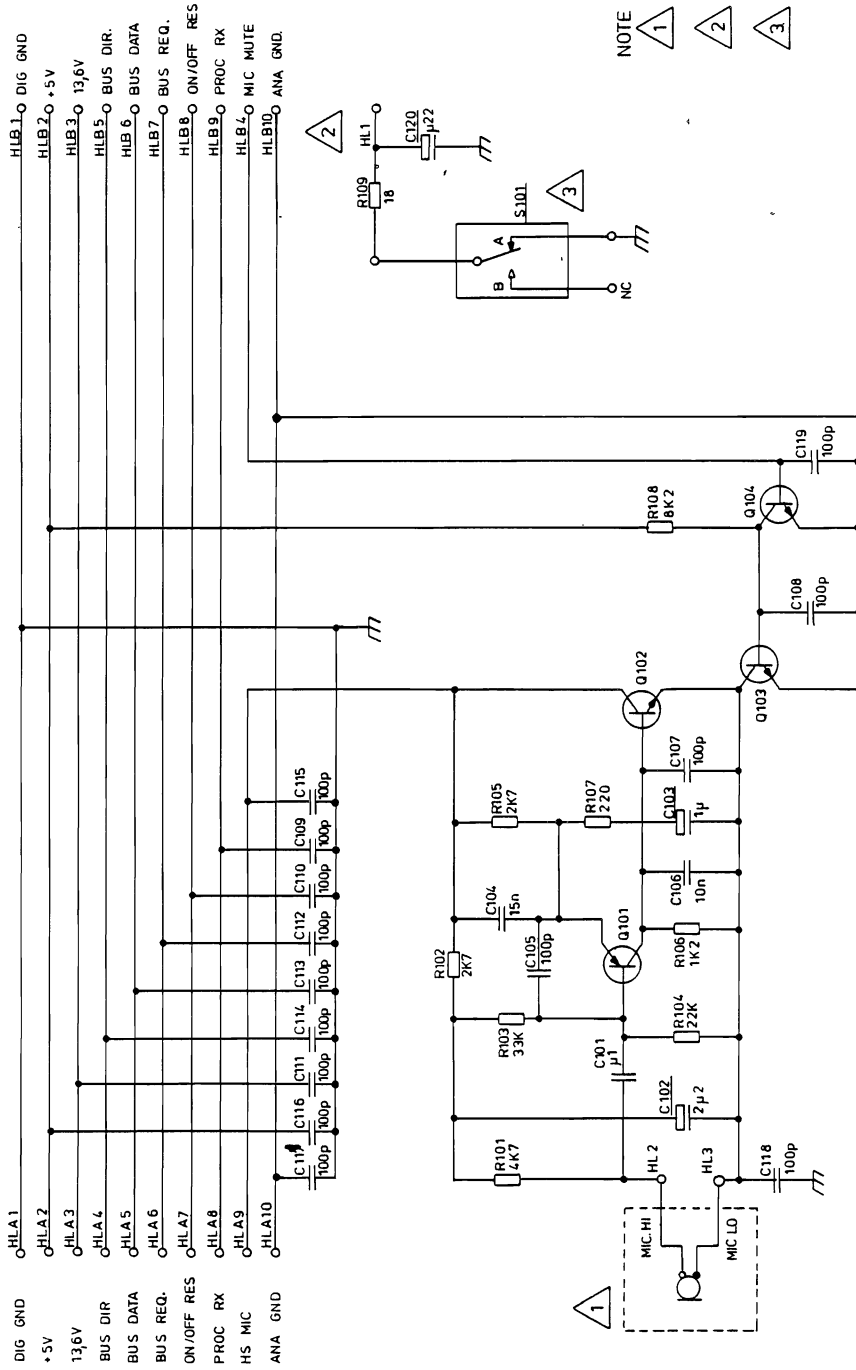

- NOTE
- 1
 - 2
 - 3

MIC IS NOT A PART OF THIS ASSEMBLY
GROUND TERMINAL IS CONNECTED TO
HOUSING
WIRE SOLDERED TO CL 6003 BOARD H12.
(99M905982) THE WIRE IS NOT A PART
OF THIS ASSEMBLY
HOOK SWITCH, THE REED RELAY IS IN
POSITION A, WHEN THE HANDSET IS
REMOVED FROM THE RETAINER

COMPONENTS MARKED CXXX
ARE PLACED ON SOLDER SIDE

>> THIS DOCUMENT REMAINS STORNO'S PROPERTY
AND STORNO RESERVES ALL RIGHTS IN RESPECT
TO THIS DOCUMENT. WITHOUT STORNO'S WRITTEN
PERMISSION THE CONTENTS OF THE DOCUMENT
MUST NOT BE IMPARTED TO A THIRD PARTY NOR
BE USED FOR ANY UNAUTHORIZED PURPOSE <<

COMPONENT SIDE

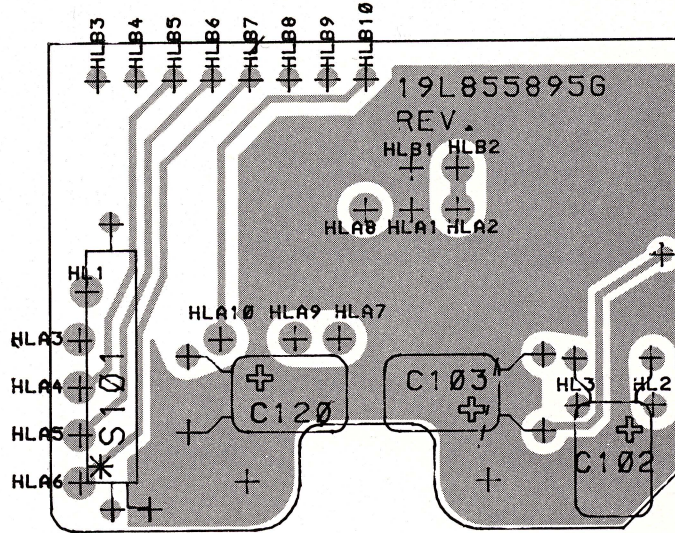

CHIP SIDE

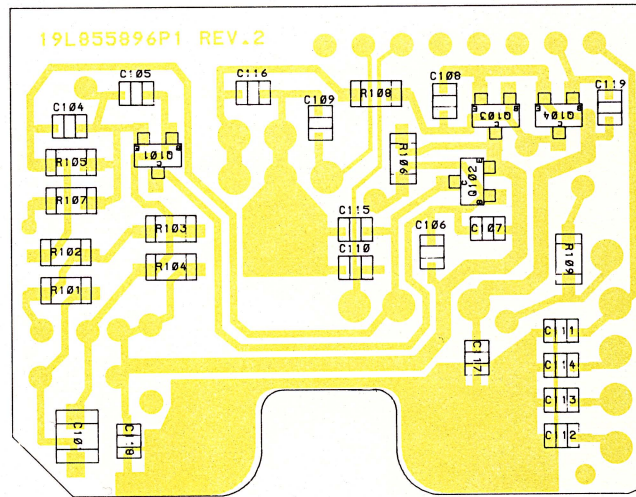

AUDIO AMPLIFIER AA6001
COMPONENT LAYOUT

CODE NO. L855895G1

REV.2

D404.428

Storno

Pos.	Code No.	Description	Qt.
00A1	L855651G1	AA 6002	1
00A2	L855895G1	AA 6001 ASM	1
00W1	J707179P10	WIRE STRD BLACK 0.055 MM	
00W2	J707179P6	WIRE STRD BLUE 0.055 MM	
00W3	J708319P2	WIRE 0.250 SQ RED	
0002	M906033P1	INTEGRATED CKT FOIL	1

Storno

Pos.	Code No.	Description	Qt.

AA6002

AUDIO AMPLIFIER

The AA6002 is the board in the handset which contains the amplifier and volume control.

The amplifier gain is controlled by R245, R247, R248, C209 and C213. R248 and C213 are used for correction of the frequency response of the earphone.

The volume control consists of:

- Oscillator
- Binary UP/DOWN counter
- Analog multiplexer
- Control logic

The input signal (PROC RX) is attenuated by R227 - E234, in steps of 5 dB. The multiplexer is used for making a connection between one of these levels and the earphone amplifier.

R210 - R214 and C202 form the basis of the oscillator. D202 is used to stop the oscillator depending on the voltage at the collector of Q202.

The oscillator is used as a clock for the binary UP/DOWN counter. The output from the UP/DOWN counter controls the multiplexer.

Assume that UP and DOWN are floating. Then the outputs at pins 2 and 13 of the comparator (U201) are high. If the function of Q201, Q203 and Q204 is neglected then Q202 is cut off, which means that the voltage is low at the collector of Q202.

This prevents the oscillator from oscillating because the output of the comparator is an open collector. The capacitor C202 is discharged through D202.

When UP goes high the output at pin 2 (of the comparator) goes down and Q202 is saturated. This starts the oscillator. Because down is not connected, UP/DN (on the binary UP/DOWN counter U203) is high. Therefore the oscillator starts counting. To prevent the counter from counting in a circle (from "1111" to "0000") the oscillator has to be stopped.

This is done by the output TC (from the binary UP/DOWN counter) which goes LOW when the output is "1111". This causes Q201 to be saturated and Q202 to be in cut off position which stops the oscillator.

When DOWN goes high pins 2 and 13 on the comparator go low, which results in that the counter starts down counting.

To prevent the counter from counting from "0000" to "1111", Q204 is cut off when the output is "0000" (in all other situations Q204 is saturated). When Q204 is cut off, Q203 is saturated if DOWN is high. This saturates Q201 and stops the oscillator.

When the supply is switched on, the volume is set to level Y3 (on U202).

SPECIFICATIONS

INTERFACE

PROC RX

AC coupled: $5 \text{ Kohm} \leq R_{in} \leq 10 \text{ Kohm}$

LS

HIGH: $>4 \text{ V}$ (muted)

LOW: $<0.5 \text{ V}$

Input of a CMOS device parall. with 47 Kohm

UP

HIGH: >3 V Rin >200 Kohm
LOW: no connection

DOWN

HIGH: >3 V Rin >200 Kohm
LOW: no connection

Power supply

5 V

Consumption

<30 mA

Nominal input

300 mV

Earphone impedance

1800 ohm

Gain

Maximum: 12 dB

Nominal: -8 dB

Temperature range

-25°C to +55°C

Dimensions

L x W x H: 50 mm x 44 mm x 1.75 mm

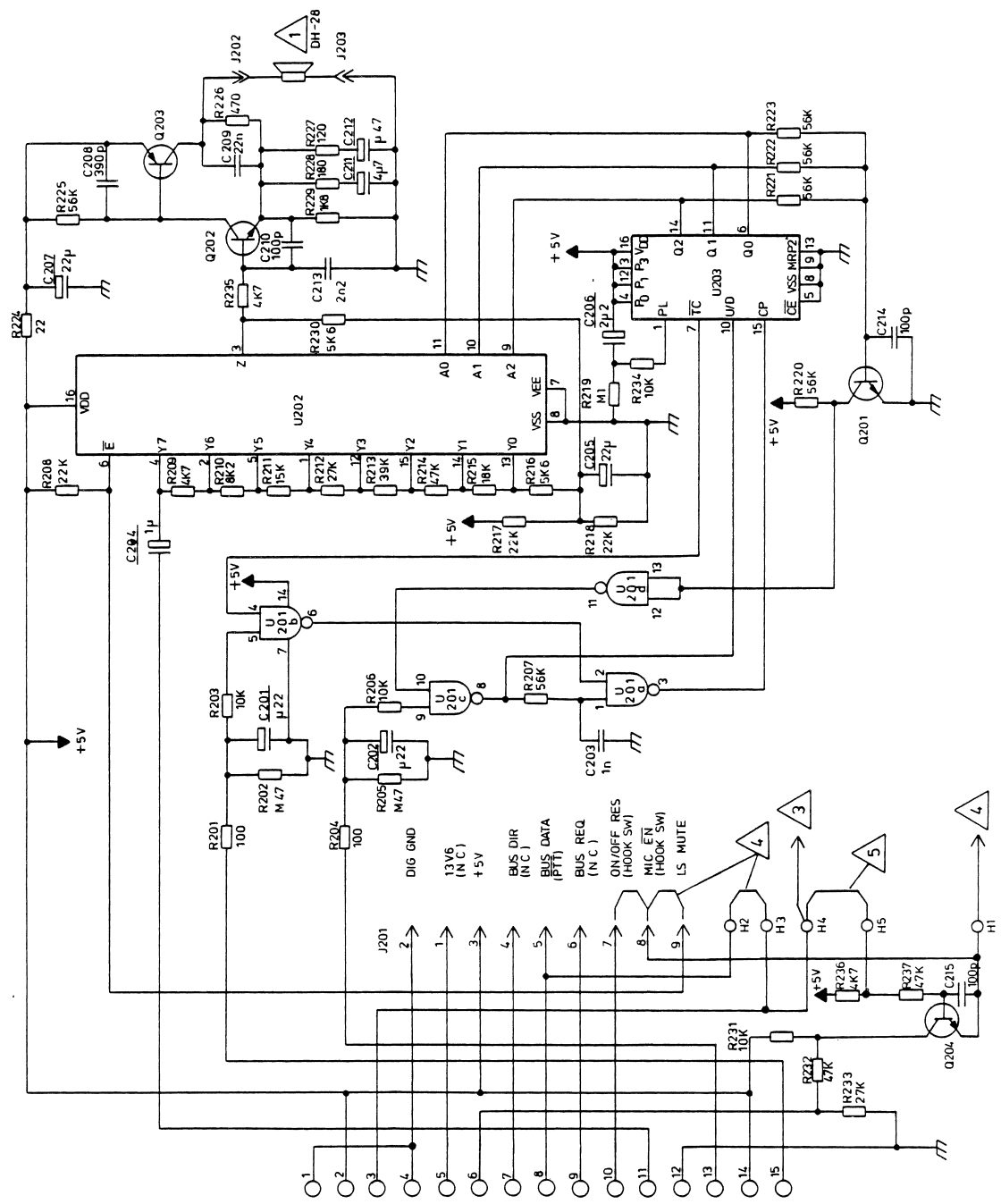

- DIG GND
- + 5V
- PTT SW
- DIG GND
- 13V6
- MIC MUTE
- BUS DIR
- BUS DATA
- BUS REQ
- ON/OFF RES
- PROC RX
- ANA GND
- VOL DOWN
- + 5V
- VOL UP

NOTE:

- 1 EARPHONE IS NOT PART OF THIS ASM
- 2 COMPONENTS MARKED RXXX ARE PLACED ON NO SOLDER SIDE
- 3 WIRE CONNECTED TO CL6003, H14.
- 4 IN THE MT6004 AND MT6007 VERSIONS (CL6003 REMOVED), WIRE CONNECT BETWEEN H2 AND H3 WIRE CONNECT BETWEEN PIN 7, 8 AND 9, J201 THE WIRE FROM THE HOOK SWITCH, AA 6001, IS CONNECTED TO H1
- 5 CONNECTED IN THE MT6004 (DUPLX VERSION)
- 6 DESIGNATIONS IN PARANTHESES REFER TO MT 6004 AND MT6007

>>THIS DOCUMENT REMAINS STORNO'S PROPERTY AND STORNO RESERVES ALL RIGHTS IN RESPECT TO THIS DOCUMENT. WITHOUT STORNO'S WRITTEN PERMISSION THE CONTENTS OF THE DOCUMENT MUST NOT BE IMPARTED TO A THIRD PARTY NOR BE USED FOR ANY UNAUTHORIZED PURPOSE <<

COMPONENT SIDE

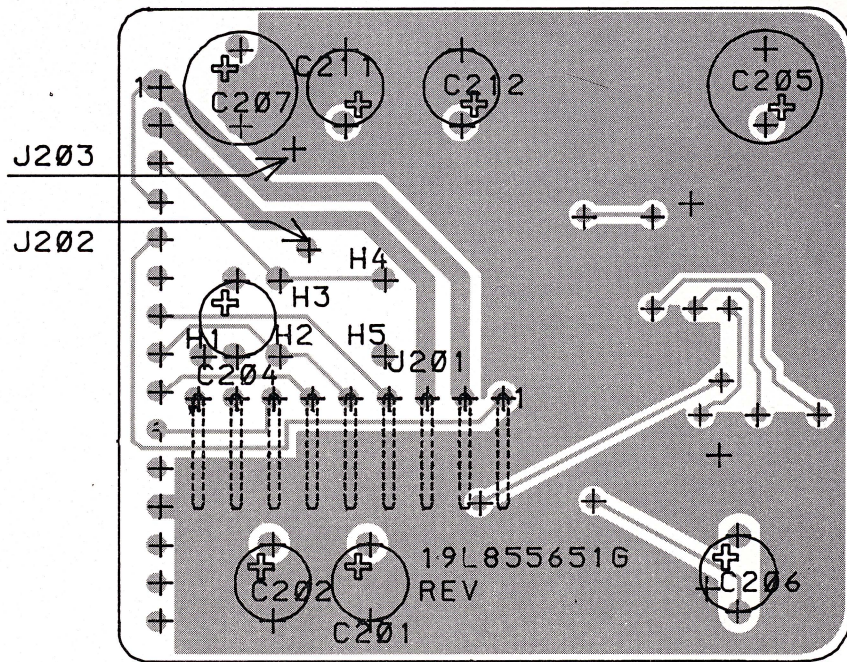

CHIP SIDE

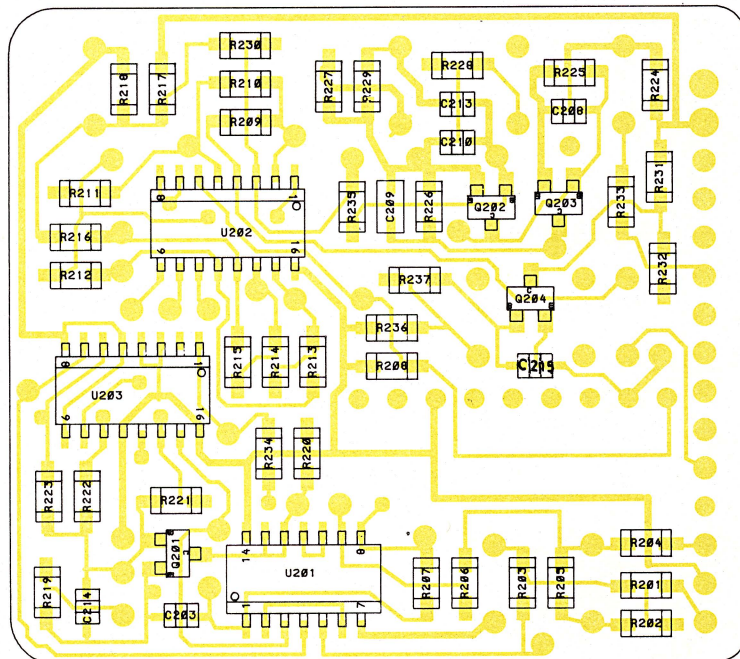

AUDIO AMPLIFIER AA6002
COMPONENT LAYOUT

CODE NO. L855651G1

REV.2

D404.426

Storno**Storno**

Pos.	Code No.	Description	Qt.
C201	J707444P2	CAP TA SOL OU22 20% 35V	1
C202	J707444P2	CAP TA SOL OU22 20% 35V	1
C203	J707438P5	CAP CER CL2 1N 10% 50V	1
C204	J707444P4	CAP TA SOL 1U 20% 35V	1
C205	J707444P8	CAP TA SOL 22U 20% 16V	1
C206	J707444P5	CAP TA SOL 2U2 20% 35V	1
C207	J707444P8	CAP TA SOL 22U 20% 16V	1
C208	J707436P75	CAP CER NPO 390P 5% 50V	1
C209	J707438P18	CAP CER CL2 22N 10% 50V	1
C210	J707436P61	CAP CER NPO 100P 5% 50V	1
C211	J707444P6	CAP TA SOL 4U7 20% 35V	1
C212	J707444P3	CAP TA SOL OU47 20% 35V	1
C213	J707438P5	CAP CER CL2 1N 10% 50V	1
C214	J707436P61	CAP CER NPO 100P 5% 50V	1
C215	J707436P61	CAP CER NPO 100P 5% 50V	1
J201	J708925P2	CONN PT PIN L-11,7	9
J202	J708925P1	CONN PT PIN L-9,7	1
J203	J708925P1	CONN PT PIN L-9,7	1
Q201	J707386P1	TSIR NPN SI BCW 32	1
Q202	J707386P1	TSIR NPN SI BCW 32	1
Q203	J707387P1	TSIR PNP SI BCW 30	1
Q204	J707386P1	TSIR NPN SI BCW 32	1
R201	J707385P103	RES MFILM 10K 5% 1/8W	1
R202	J707385P474	RES MFILM 470K 5% 1/8W	1
R203	J707385P103	RES MFILM 10K 5% 1/8W	1
R204	J707385P101	RES MFILM 100R 5% 1/8W	1
R205	J707385P474	RES MFILM 470K 5% 1/8W	1
R206	J707385P103	RES MFILM 10K 5% 1/8W	1
R207	J707385P563	RES MFILM 56K 5% 1/8W	1
R208	J707385P223	RES MFILM 22K 5% 1/8W	1
R209	J707385P472	RES MFILM 4K7 5% 1/8W	1
R210	J707385P822	RES MFILM 8K2 5% 1/8W	1
R211	J707385P153	RES MFILM 15K 5% 1/8W	1
R212	J707385P273	RES MFILM 27K 5% 1/8W	1
R213	J707385P393	RES MFILM 39K 5% 1/8W	1
R214	J707385P473	RES MFILM 47K 5% 1/8W	1

Pos.	Code No.	Description	Qt.
R215	J707385P183	RES MFILM 18K 5% 1/8W	1
R216	J707385P562	RES MFILM 5K6 5% 1/8W	1
R217	J707385P223	RES MFILM 22K 5% 1/8W	1
R218	J707385P223	RES MFILM 22K 5% 1/8W	1
R219	J707385P104	RES MFILM 100K 5% 1/8W	1
R220	J707385P563	RES MFILM 56K 5% 1/8W	1
R221	J707385P563	RES MFILM 56K 5% 1/8W	1
R222	J707385P563	RES MFILM 56K 5% 1/8W	1
R223	J707385P563	RES MFILM 56K 5% 1/8W	1
R224	J707385P220	RES MFILM 22R 5% 1/8W	1
R225	J707385P563	RES MFILM 56K 5% 1/8W	1
R226	J707385P471	RES MFILM 470R 5% 1/8W	1
R227	J707385P121	RES MFILM 120R 5% 1/8W	1
R228	J707385P181	RES MFILM 180R 5% 1/8W	1
R229	J707385P182	RES MFILM 1K8 5% 1/8W	1
R230	J707385P562	RES MFILM 5K6 5% 1/8W	1
R231	J707385P103	RES MFILM 10K 5% 1/8W	1
R232	J707385P473	RES MFILM 47K 5% 1/8W	1
R233	J707385P273	RES MFILM 27K 5% 1/8W	1
R234	J707385P103	RES MFILM 10K 5% 1/8W	1
R235	J707385P472	RES MFILM 4K7 5% 1/8W	1
R236	J707385P472	RES MFILM 4K7 5% 1/8W	1
R237	J707385P473	RES MFILM 47K 5% 1/8W	1
R256	J707385P683	RES MFILM 68K 5% 1/8W	1
U201	J708786P1	IC DIG GATE 74HC132	1
U202	J707434P1	IC DIG MUX 4051 CMOS	1
U203	J707331P4	IC DIG CNTR 4516 CMOS	1
0002	L855652P1R2	BD PW	1

Parts List AUDIO AMPLIFIER/VOL. CONTROL AA6002 : L855651G1

X404. 442

Page No. 1/1

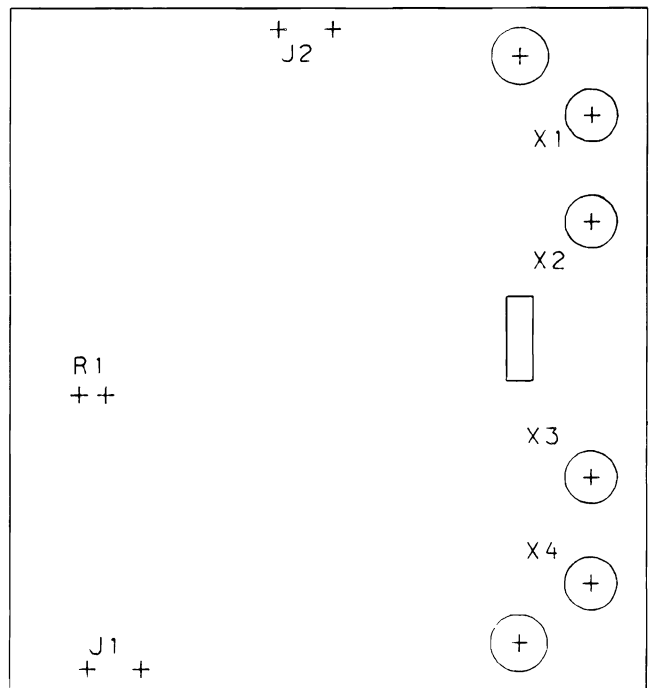
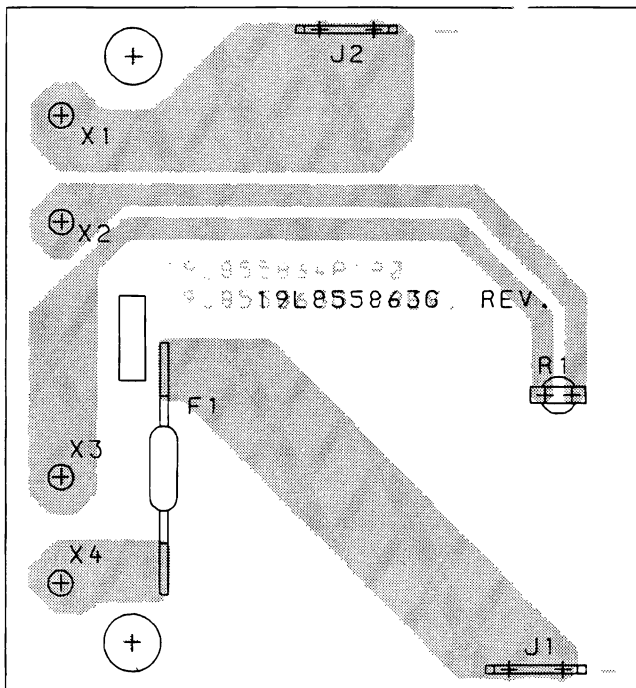
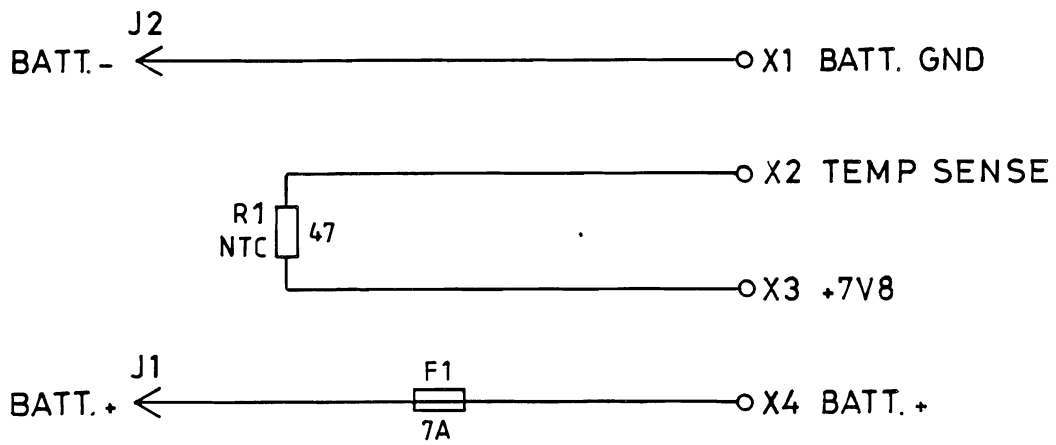

SOLDER SIDE

MODUL CODE NO. L855862G1 - BU6001

MODUL CODE NO. L855862G2 - BU6002

BATTERY UNIT BU6001/2

D404. 388

ITEM NUMBER	DESCRIPTION
L855862G1	BU 6001, NI-CD BATTERY ASM. - 13.2V 4AH
=====	
K805793G1	SUB ASM.: CASE RIVETED
K805735G1	SUB ASM.: PLATE ASM
L855863G1	SUB-SUB ASM.: COMPONENT BD ASM

P A R T S L I S T :

CIRCUIT POSITION	COMPONENT ITEM NUMBER	COMPONENT DESCRIPTION	QUANTITY	
0002	K805793G1	CASE, RIVETED-	1	(SEE BELOW)
0005	K805723P1	PLATE, INSULATION-	1	
0006	J709370P1	BATTERY,STOR.- NI-CD, 12V 4AH	1	
0008	K805725P1	FOAM	1	
0009	K805735G1	PLATE ASM	1	(SEE BELOW)
0010	A701932P306	SCREW FL HD SZ 2.9 X 9.5 MM	4	
0011	J709395P1	FOAM	2	
0012	K805772P1	PLATE, FOAM-	2	
0013	K805773P1	PLATE, FOAM-	2	

0002 :	K805793G1 :	CASE RIVETED :		

0002	J709196G1	CASE, PAINTED-	1	
0003	J709369P1	LATCH, TENSION-	2	
0004	J708259P104	RIVET, AL.-	4	
0005	K805722P1	BRACKET	2	

0009 :	K805735G1 :	PLATE ASM :		

A001	L855863G1	COMPONENT BD ASM	1	(SEE BELOW)
0002	K805757G1	PLATE, TEXTED-	1	

A001 .	L855863G1 :	COMPONENT BD ASM., :		

F001	J707468P13 * *	FUSE ENCLOSED LINK 10A	1	
J001	J706683P1	TERM SPADE TAB 6.3MM	1	
J002	J706683P1	TERM SPADE TAB 6.3MM	1	
R001	J707406P5	RES THERM NTC 47K 10%	1	
X001	J709212P1	CONTACT PIN	1	

CIRCUIT POSITION	COMPONENT ITEM NUMBER	COMPONENT DESCRIPTION	QUANTITY
X002	J709212P1	CONTACT PIN	1
X003	J709212P1	CONTACT PIN	1
X004	J709212P1	CONTACT PIN	1
0002	L855864P1R0	BD PW., REVISION NO.: 0	1
0008	J708296P4	SLV ⁺ INS ELEC PTFE CL R	0,040 M
0009	A700032P1	WASHER LOK TOH D-2.0 MM	4

ITEM NUMBER	DESCRIPTION
L855862G2	BU 6002, NI-CD BATTERY ASM. - 13,2V 7A
K805793G2	SUB ASM.: CASE RIVETED
K805735G2	SUB ASM.: PLATE ASM
L855863G1	SUB-SUB ASM.: COMPONENT BD ASM

P A R T S L I S T :

CIRCUIT POSITION	COMPONENT ITEM NUMBER	COMPONENT DESCRIPTION	QUANTITY	
0002	K805793G2	CASE, RIVETED-	1	(SEE BELOW)
0005	K805723P1	PLATE, INSULATION-	1	
0006	J709371P1	BATTERY STOR.NI CD 12V	1	
0008	K805725P1	FOAM	1	
0009	K805735G2	PLATE ASM	1	(SEE BELOW)
0010	A701932P306	SCREW FL HD SZ 2.9 X 9.5 MM	4	
0011	J709395P2	FOAM	2	
0012	K805772P2	PLATE, FOAM-	2	
0013	K805773P2	PLATE, FOAM-	2	

0002 :	K805793G2 :	CASE RIVETED :		
0002	J709196G2	CASE, PAINTED-	1	
0003	J709369P1	LATCH, TENSION-	2	
0004	J708259P104	RIVET, AL.-	4	
0005	K805722P1	BRACKET	2	

0009 :	K805735G2 :	PLATE ASM :		
A001	L855863G1	COMPONENT BD ASM	1	(SEE BELOW)
0002	K805757G2	PLATE, TEXTED-	1	

A001 .	L855863G1 :	COMPONENT BD ASM., :		
F001	J707468P13 * *	FUSE ENCLOSED LINK, 10A	1	
J001	J706683P1	TERM SPADE TAB 6.3MM	1	
J002	J706683P1	TERM SPADE TAB 6.3MM	1	
R001	J707406P5	RES THERM NTC 47K 10%	1	
X001	J709212P1	CONTACT PIN	1	

CIRCUIT POSITION	COMPONENT ITEM NUMBER	COMPONENT DESCRIPTION	QUANTITY
X002	J709212P1	CONTACT PIN	1
X003	J709212P1	CONTACT PIN	1
X004	J709212P1	CONTACT PIN	1
0002	L855864P1R0	BD PW., REVISION NO.: 0	1
0008	J708296P4	SLV INS ELEC PTFE CL R	0,040 M
0009	A700032P1	WASHER LOK TOH D-2.0 MM	4

Storno

Storno

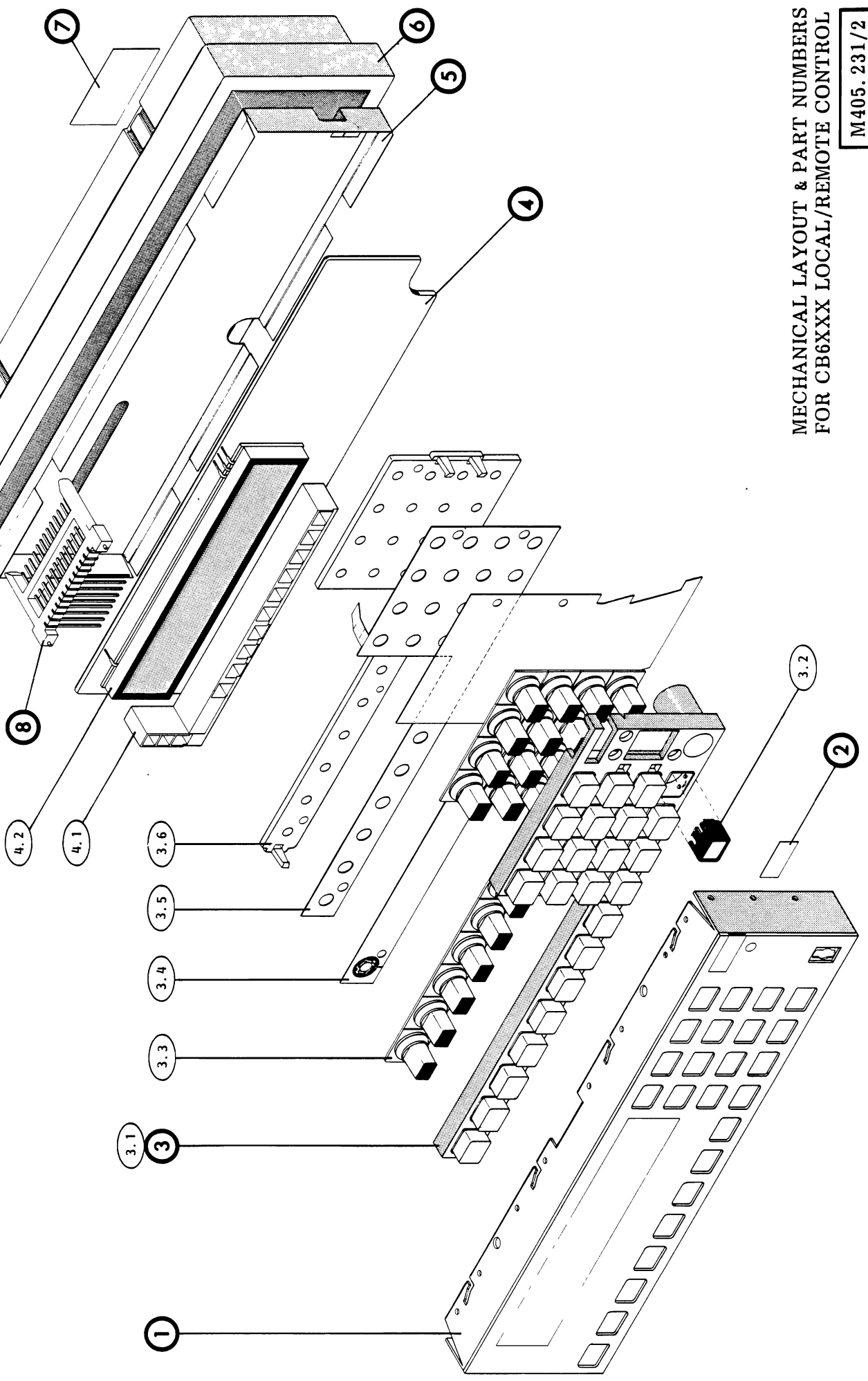

MECHANICAL LAYOUT & PART NUMBERS
FOR CB6XXX LOCAL/REMOTE CONTROL

M405. 231/2

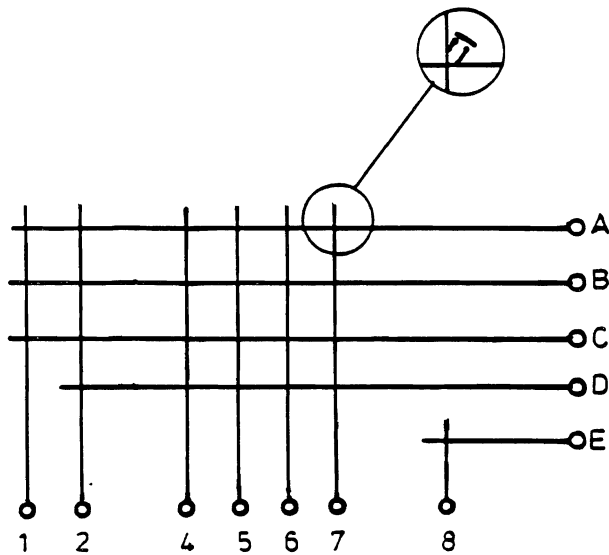

DIAGRAM

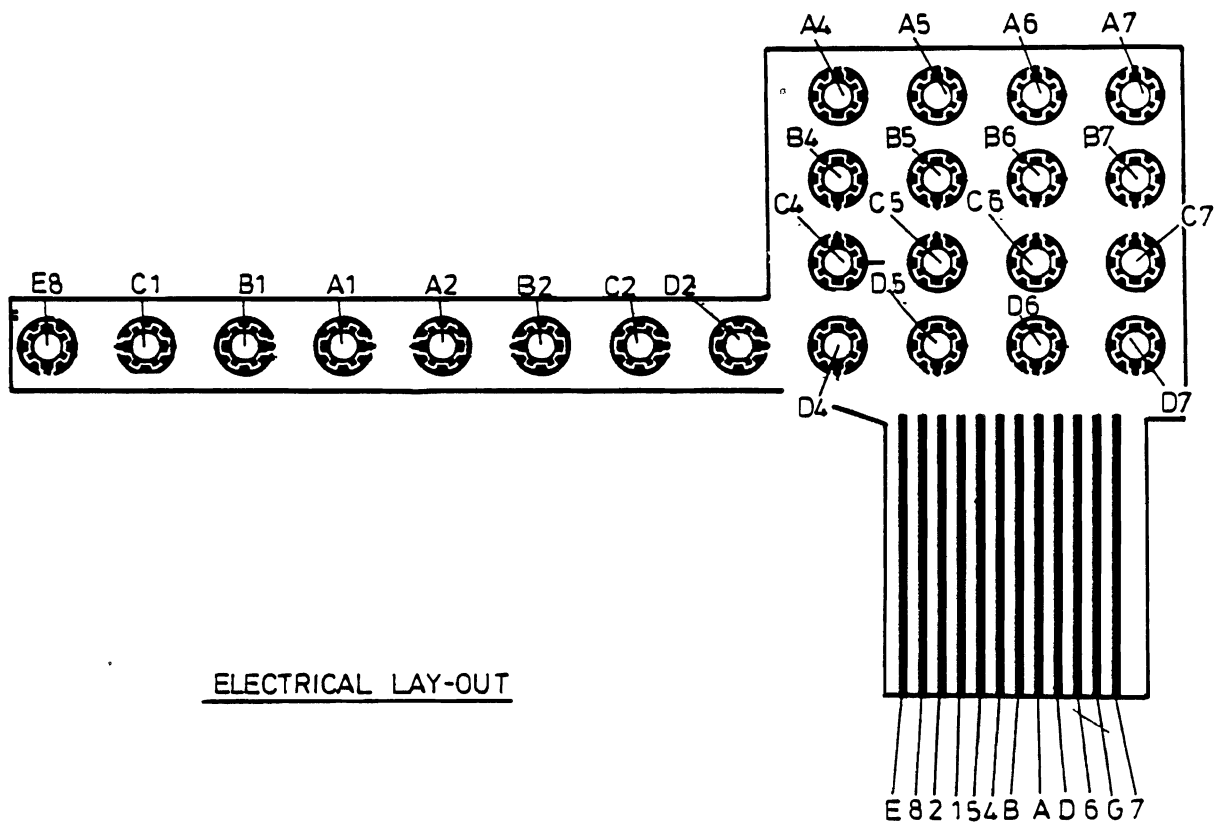

ELECTRICAL LAY-OUT

KEYBOARD MATRIX FOR CB6XXX
 CODE NO. K805526G1 D404.174

CONTROL TYPE	DESCRIPTION
CB6010DL	CB 6010, LOCAL CONTROL PANEL, FOR STORNOMATIC 6000 - N M T. VERSIONS: D/N AND S/Y
CB6010NL	
CB6010SL	
CB6010YL	

=====

M A I N P A R T S L I S T :

INDEX-TABLE/ POSIT.-PREFIX	COMPONENT ITEM NO.:	COMPONENT DESCRIPTION	QUANTITY
CB6,02,005 :			
0002	M905787G1	HOUSING ASM	1
0003	J709215G1	SHIELD ASM	1
A: 0004	L855630G1	CHASSIS ASM	1 (SEE BELOW)
0010	L855664G2	WAFER ASM.,CONNECTOR 09 CKT	1
CB6,03,003/-,004 :			
A: 0001	L855628G1	KEYBOARD ASM (DENMARK/NORWAY)	1 (SEE BELOW)
OR :			SEE:
A: 0001	L855628G2	KEYBOARD ASM (SWEDEN/FINLAND)	1 PAGE 2
CB6,04,004 :			
A: 0002	M905980G1	CL 6003	1 (SEE:- X404.022)
CB6,05,001 :			
0001	J709045P1	LABEL BLANK	1
0002	J709042P1	LABEL TYPE CB	1

CIRCUIT POSITION	COMPONENT ITEM NUMBER	COMPONENT DESCRIPTION	QUANTITY
0004 :	L855630G1 :	CHASSIS ASM. :	
0002	M905785P1	FRONT, CHASSIS-	1
0003	M906145G2	FRONT, PRINTED-	1
0005	J706922P3	TAPE, PRESSURE SENSITIVE-	0,10 M
0006	J706922P3	TAPE, PRESSURE SENSITIVE-	0,050 M
0001 :	L855628G1 :	KEYBOARD ASM. (DENM./NORW.) :	
0002	M905792P1	PLATE, L E D LIGHT-	1

CIRCUIT POSITION	COMPONENT ITEM NUMBER	COMPONENT DESCRIPTION	QUANTITY
0003	K805526G1	FOIL, CONTACT-	1
0004	K805539G1	MEMBRANE, CONTACT-RUBBER-	1
0005	M905789P1	FRAME	1
0006	L855562P1	CAP	24
* 0007	* K805752G1	* SHIELD, KEYBOARD-	* 1

0001 :	L855628G2 :	KEYBOARD ASM. (SWED./FINL.) :	
0002	M905792P1	PLATE, L E D LIGHT-	1
0003	K805526G1	FOIL, CONTACT-	1
0004	K805539G2	MEMBRANE, CONTACT-RUBBER-	1
0005	M905789P1	FRAME	1
0006	L855562P1	CAP	24
* 0007	* K805752G1	* SHIELD, KEYBOARD-	* 1

CONTROL TYPE	DESCRIPTION
CB6010DR	CB 6010, REMOTE CONTROL BOX,
CB6010NR	FOR STORNOMATIC 6000 - N M T.
CB6010SR	VERSIONS: D/N AND S/Y
CB6010YR	

=====

M A I N P A R T S L I S T :

INDEX-TABLE/ POSIT.-PREFIX	COMPONENT ITEM NO.	COMPONENT DESCRIPTION	QUANTITY
CB6,02,006 :			
0002	M905787G1	HOUSING ASM	1
0003	J709215G1	SHIELD ASM	1
A: 0004	L855630G1	CHASSIS ASM	1 (SEE BELOW)
A: 0009	K805596G1	CC 6005 CABLE KIT	1 (SEE BELOW)
CB6,03,003/-,004 :			
A: 0001	L855628G1	KEYBOARD ASM (DENMARK/NORWAY)	1 SEE: PAGE 2
OR :			
A: 0001	L855628G2	KEYBOARD ASM (SWEDEN/FINLAND)	1 SEE: PAGE 2
CB6,04,004 :			
A: 0002	M905980G1	CL 6003	1 (SEE:- X404.022)
CB6,05,001 :			
0001	J709045P1	LABEL BLANK	1
0002	J709042P1	LABEL TYPE CB	1

CIRCUIT POSITION	COMPONENT ITEM NUMBER	COMPONENT DESCRIPTION	QUANTITY
0004 :	L855630G1 :	CHASSIS ASM. :	
0002	M905785P1	FRONT, CHASSIS-	1
0003	M906145G2	FRONT, PRINTED-	1
0005	J706922P3	TAPE, PRESSURE SENSITIVE-	0,10 M
0006	J706922P3	TAPE, PRESSURE SENSITIVE-	0,050 M
0009 :	K805596G1 :	CC 6005 CABLE KIT :	
P001	J708069P214	CONNECTOR FEM	1

CIRCUIT POSITION	COMPONENT ITEM NUMBER	COMPONENT DESCRIPTION	QUANTITY
P002	A700041P40	CONN,HSC FEM 14 CKT	1
W001	J706156P5	CA 14 CORED	3,50 M
0002	J707787P1	CONN PWB FEM RECP CLIP	14
0003	J706152P5	STRAP RET W BDL D19 NYL	2
0004	J707335P1	CLAMP LOOP 5 MM	1
0005	A700031P405	SCREW PAN HD M-3.0X5.0 MM	1
0006	J708981P1	CONNECTOR	1

0001 :	L855628G1 :	KEYBOARD ASM. (DENM./NORW.) :	

0002	M905792P1	PLATE, L E D LIGHT-	1
0003	K805526G1	FOIL, CONTACT-	1
0004	K805539G1	MEMBRANE, CONTACT-RUBBER-	1
0005	M905789P1	FRAME	1
0006	L855562P1	CAP	24
* 0007	* K805752G1	* SHIELD, KEYBOARD-	* 1

0001 :	L855628G2 :	KEYBOARD ASM. (SWED./FINL.) :	

0002	M905792P1	PLATE, L E D LIGHT-	1
0003	K805526G1	FOIL, CONTACT-	1
0004	K805539G2	MEMBRANE, CONTACT-RUBBER-	1
0005	M905789P1	FRAME	1
0006	L855562P1	CAP	24
* 0007	* K805752G1	* SHIELD, KEYBOARD-	* 1

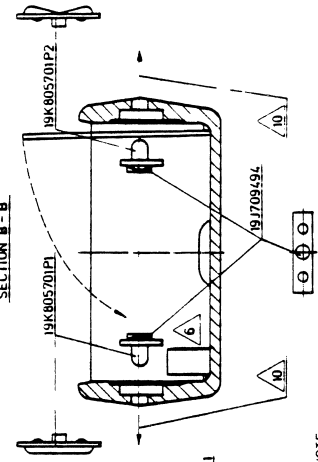
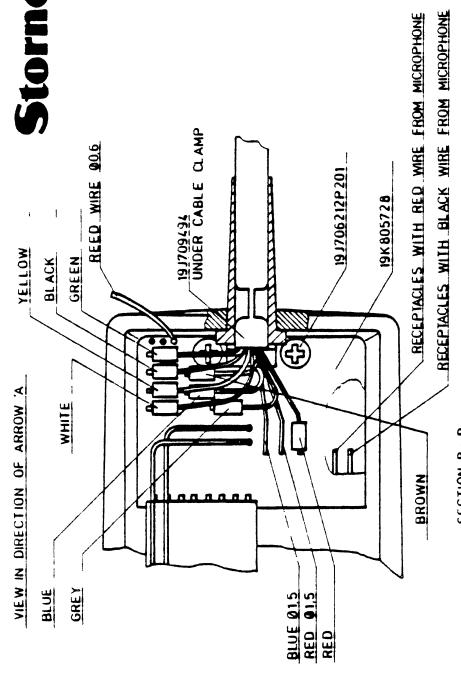

- NOTE
- 1 PLACE KEYBOARD ASM 19L855628 ON 19M905980 AND INSERT KEYBOARD TAIL INTO J201
 - 2 BEND 4 KEYBOARD SHIELD ENDS ON PWB 19M905980
 - 3 PUT PWB AND KEYBOARD INTO CHASSIS ASM 19L855630
 - 4 PRESS PWB AGAINST CHASSIS AND BEND 7 TABS DO NOT BEND THE TWO TABS ON THE OPPOSITE SIDE OF THE CHASSIS
 - 6 USE THE INSULATION SHEET'S WING TO INSULATE REEL-RELAY FROM METALISED WALL
 - 9 MOUNT PWB AND TIGHTEN TWO SCREWS 19J706212P201
 - 10 PUT KEYS 19K805701P1 AND P2 INTO HANDSET'S SLOTS
 - 11 MOUNT 4 FASTENERS 19J709041 IN HANDSET
 - 13 MOUNT CHASSIS TOGETHER WITH KEYBOARD PWB'S AND CABLING INTO HANDSET

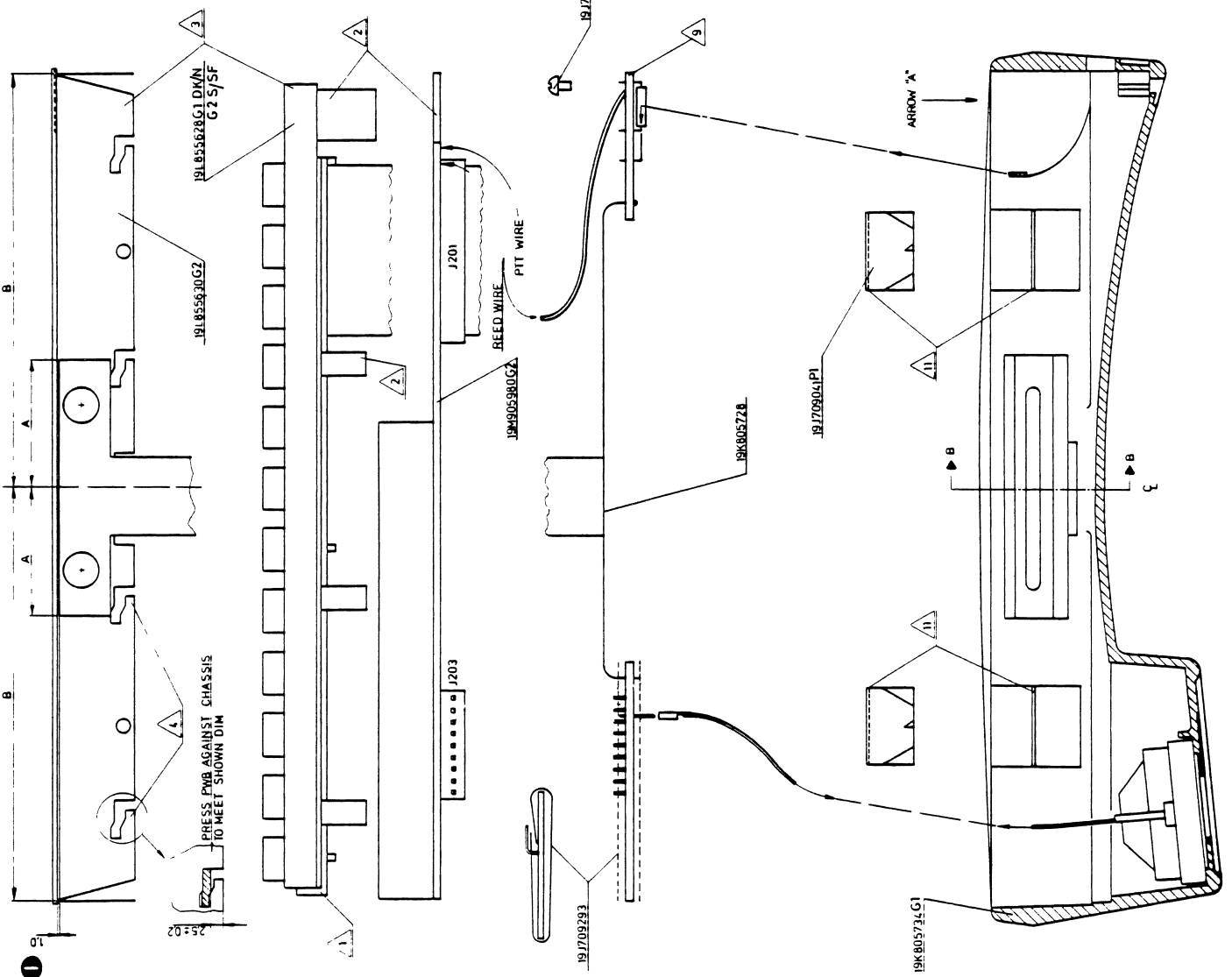

**HANDSET ASSEMBLY
M906063G1**

M405.234

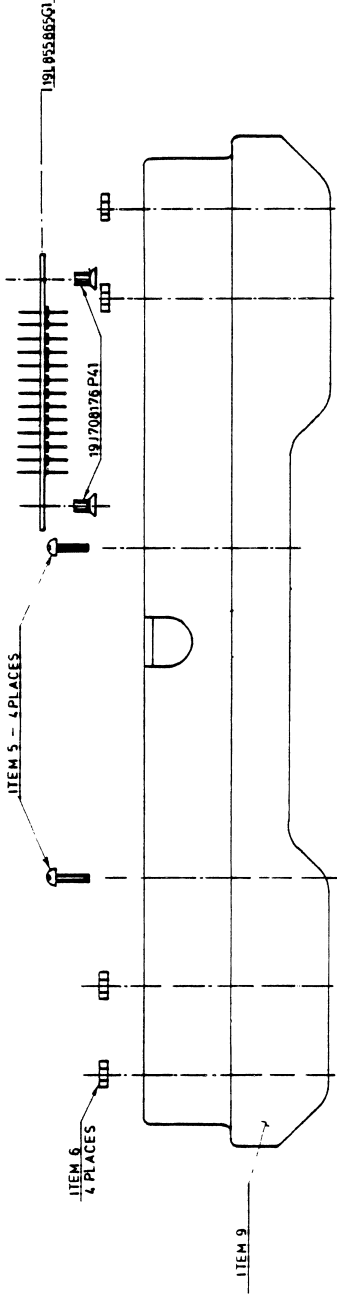
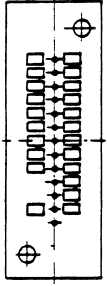

NOTES

- 1 PRESS ITEM 10 INTO ITEM 8
- 2 PLACE ITEM 2 IN ITEM 8
- 3 PLACE ITEM W1 PWB IN GROOVE IN ITEM 8.
- 4 MOUNT ITEM 2 PLUGS ON PWB PINS.
- 5 PLACE ITEM W1 SMALL PWB ON THE SPACERS AS SHOWN THEN MOUNT ITEM 13
- 6 PLACE ITEM W1 WIRING AROUND LS AS SHOWN
- 7 PLACE ITEM 9 INTO ITEM 8
- 8 MOUNT SCREW ITEM 5.
- 9 MOUNT ITEM 6 AND ITEM 7.
- 10 MOUNT PWB 19L955865 ON RADIO TURNING HOLE/PIN WITHOUT CER. CAP. AGAINST CENTER OF RADIO.

LOCAL INSTALLATION

SEE PART LIST X404.027

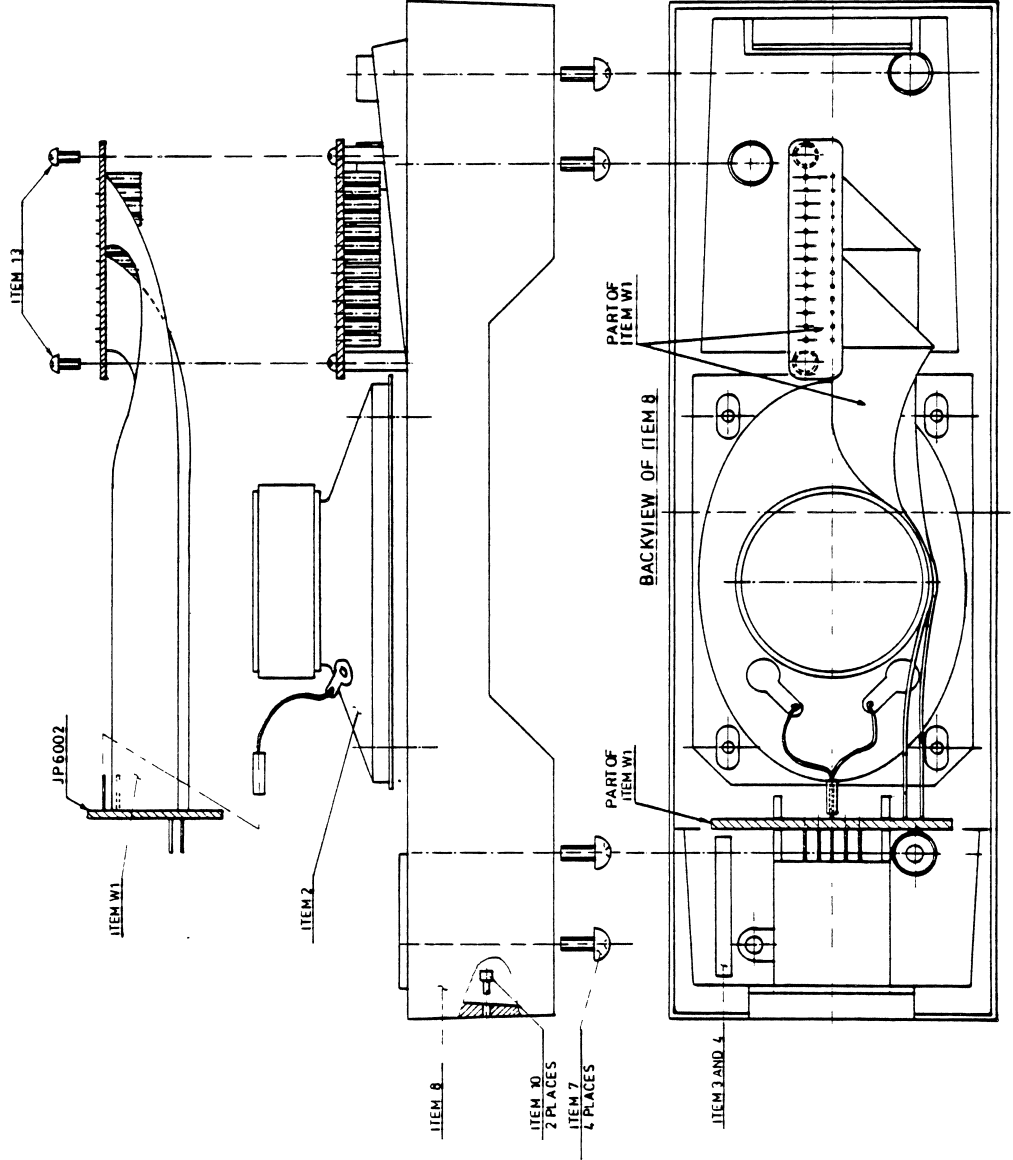

HANDSET RETAINER ASM.
M906063G1

M405.233

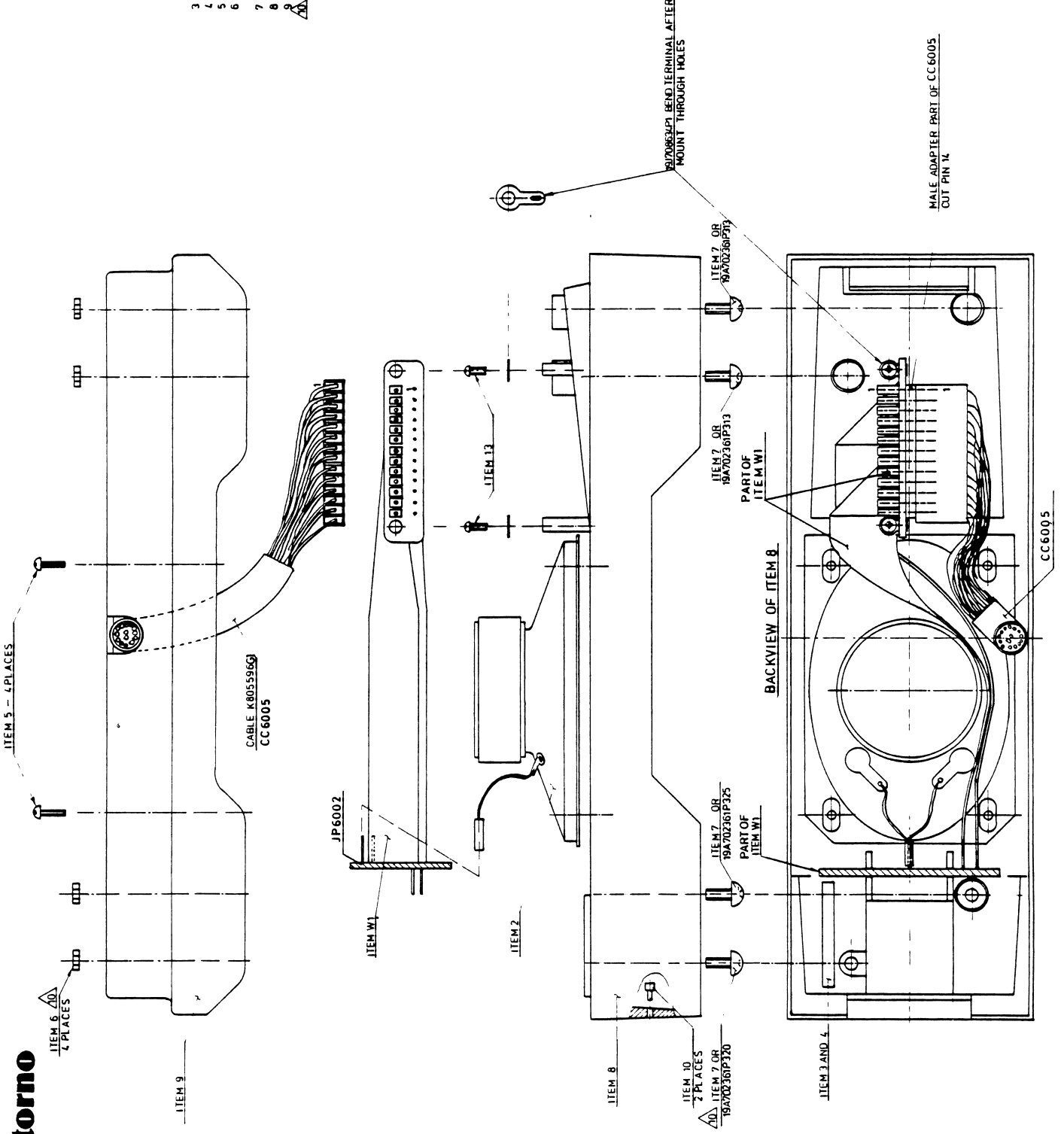

NOTES

- 1 PRESS ITEM 10 INTO ITEM 8
- 2 PLACE ITEM 2 IN ITEM 8
- 3 PLACE ITEM 1 WITH PINB IN GROOVE IN ITEM 8.
- 4 MOUNT ITEM 2 PLUGS ON PINB PINS.
- 5 PLACE ITEM W1 SHALL PINB ON THE SPACERS AS SHOWN
- 6 PLACE ITEM W1 WIRING AROUND L5 AS SHOWN
- 7 PLACE ITEM 9 INTO ITEM 8.
- 8 MOUNT SCREW ITEM 5
- 9 FOR MOUNTING OF SCREWS ITEM 7 AND NUT ITEM 6 SEE BELOW

HANDSET RETAINER MOUNTED IN	USE SCREWS	USE NUTS	INDEX
MN 6004	P306-4 PCS	P3-4 PCS	
MN 6005	P311-2 PCS	NONE	SCREWS FCFO. INDEX 19J708A16

SEE PART LIST X404.028

REMOTE INSTALLATION FOR
MN 6004 AND MN 6005

HANDSET RETAINER ASM.
M906063G1

M405.232

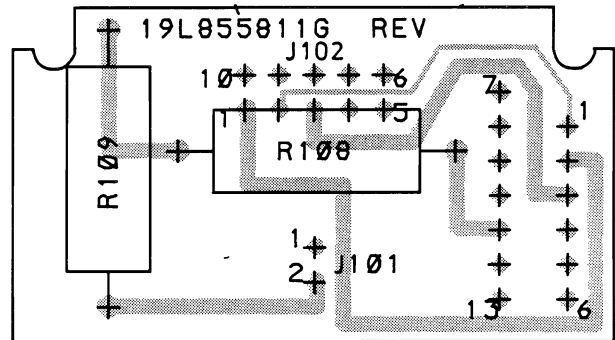
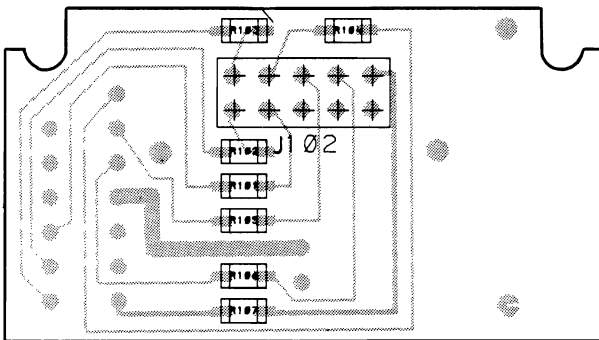
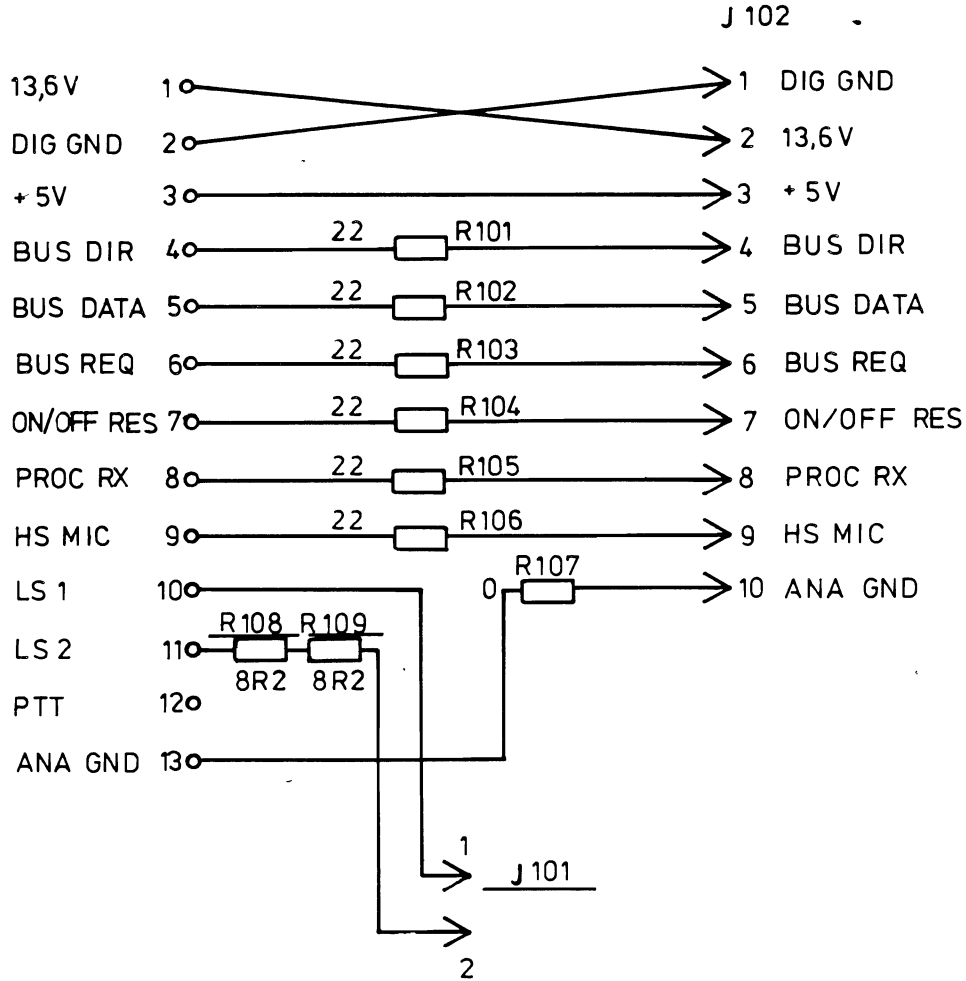

JUNCTION PANEL JP6002
 CODE NO. L855811G1 D404.172

Storno

Storno

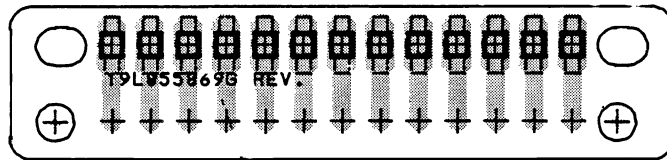

13 PIN CONNECTOR
FOR CONTROL HANDSET CB61XXX
CODE NO. L855870P1 D404.173

Storno

Storno

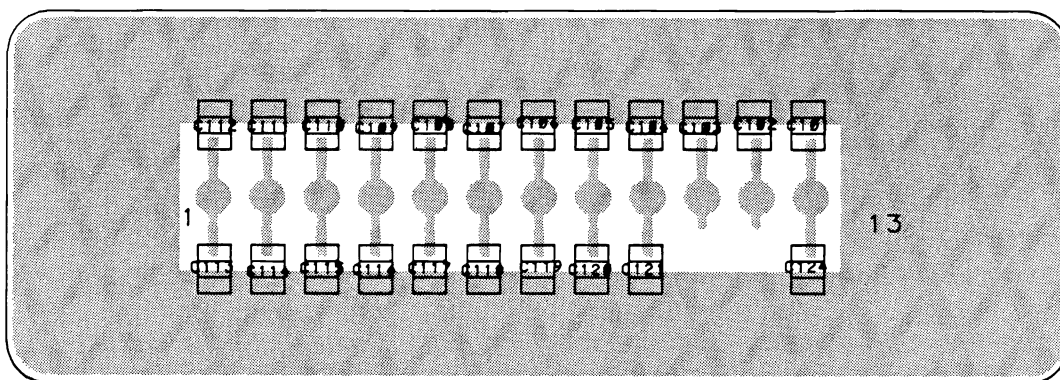
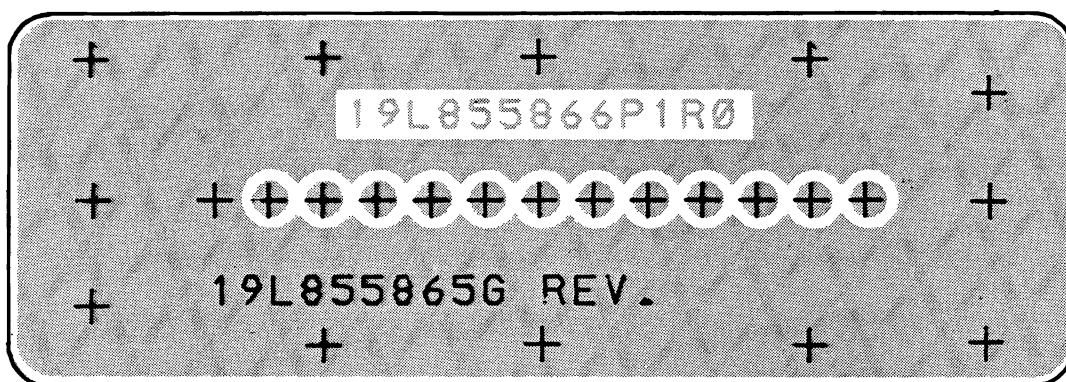
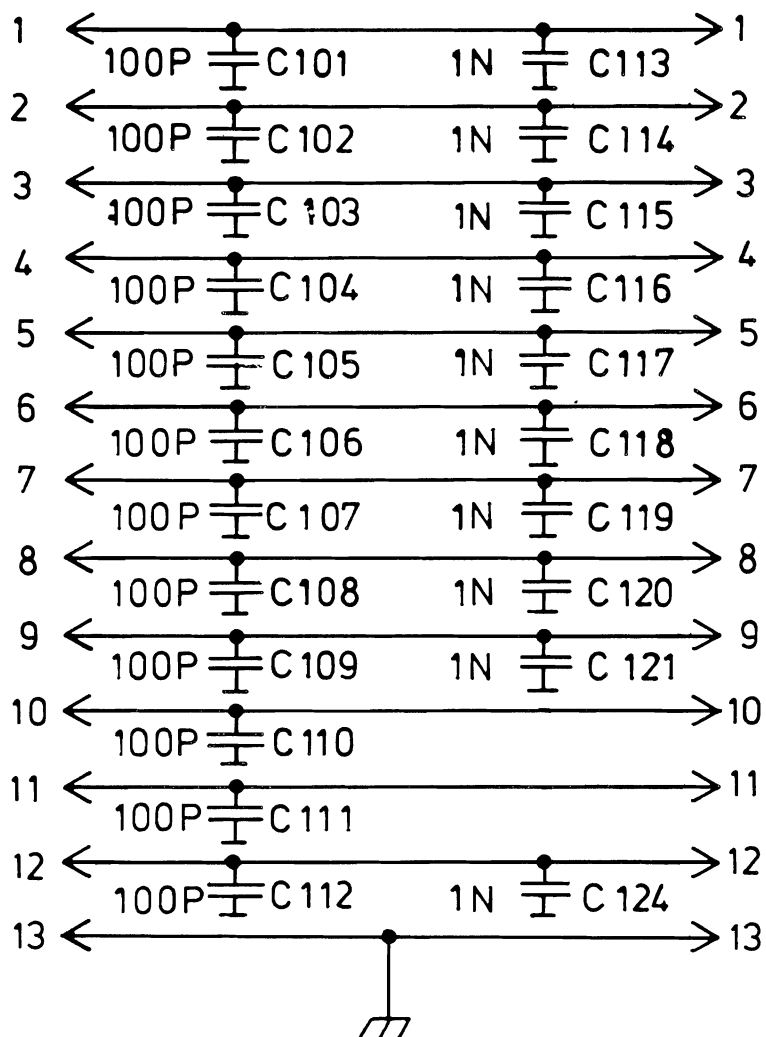

CONNECTOR ASSEMBLY FOR CONTROL HANDSET

CODE NO. L855865G1 D404.151

CONTROL TYPE	DESCRIPTION
CB6110DL	CB 6110, LOCAL HANDSET W. CONTROL PANEL F. STORNOMATIC 6000 - N M T. VERSIONS: D/N AND S/Y
CB6110NL	
CB6110SL	
CB6110YL	

M A I N P A R T S L I S T :

INDEX-TABLE/ POSIT.-PREFIX	COMPONENT ITEM NO.	COMPONENT DESCRIPTION	QUANTITY	
CB6,02,007 :				
A: 0001	L855630G2	CHASSIS ASM	1	SEE: PAGE 2
A: 0002	L855865G1	CONNECTOR BD ASM	1	SEE: PAGE 2
0003	J708176P41	SCREW FLAT HD M-2.5 X 5.0 MM	2	
A: 0005	K805734G1	HANDSET LS ASM	1	SEE: PAGE 2
0006	K805701P1	SWITCH PTT	1	
0007	K805701P2	SWITCH VOLUME	1	
0008	J709041P1	FASTENER	4	
0009	J706212P201	SCREW PAN HD SZ 4.0X4.8 MM	2	
A: 0010	M906063G1	RETAINER ASM., HANDSET-	1	SEE: PAGE 3
0011	J709494P1	SPACER	3	
0012	J709293P1	INSULATION FILM	1	
CB6,03,003/-,004 :				
A: 0001	L855628G1	KEYBOARD ASM (DENMARK/NORWAY)	1	SEE: PAGE 3
OR :				
A: 0001	L855628G2	KEYBOARD ASM (SWEDEN/FINLAND)	1	SEE: PAGE 3
CB6,04,005 :				
A: 0002	M905980G2	CL 6003 WITH HOOK SWITCH	1	SEE: X404.022
A: 0003	K805728G1	AUDIO AMPLIFIER ASM.	1	SEE: X404.024
CB6,05,001 :				
0001	J709045P1	LABEL BLANK	1	
0002	J709042P1	LABEL TYPE CB	1	
0004	J709289P1	BOOKLET, USER INSTRUCTION-	1	
0005	J709083P1	BOOKLET, PROGRAM GUIDE-	1	

CONTINUED ON NEXT PAGE: PAGE 2.

CIRCUIT POSITION	COMPONENT ITEM NUMBER	COMPONENT DESCRIPTION	QUANTITY
0001 :	L855630G2 :	CHASSIS ASM. :	
0002	M905785P1	CHASSIS FRONT	1
0003	M906145G1	FRONT PRINTED	1
0005	J706922P3	TAPE PRESSURE SENSITIVE	0,10 M
0006	J706922P3	TAPE PRESSURE SENSITIVE	0,050 M
0002 :	L855865G1 :	CONNECTOR BOARD ASM. :	
C101	J707436P61	CAP CER NPO 100P 5% 50V	1
C102	J707436P61	CAP CER NPO 100P 5% 50V	1
C103	J707436P61	CAP CER NPO 100P 5% 50V	1
C104	J707436P61	CAP CER NPO 100P 5% 50V	1
C105	J707436P61	CAP CER NPO 100P 5% 50V	1
C106	J707436P61	CAP CER NPO 100P 5% 50V	1
C107	J707436P61	CAP CER NPO 100P 5% 50V	1
C108	J707436P61	CAP CER NPO 100P 5% 50V	1
C109	J707436P61	CAP CER NPO 100P 5% 50V	1
C110	J707436P61	CAP CER NPO 100P 5% 50V	1
C111	J707436P61	CAP CER NPO 100P 5% 50V	1
C112	J707436P61	CAP CER NPO 100P 5% 50V	1
C113	J707438P5	CAP CER CL2 1N 10% 50V	1
C114	J707438P5	CAP CER CL2 1N 10% 50V	1
C115	J707438P5	CAP CER CL2 1N 10% 50V	1
C116	J707438P5	CAP CER CL2 1N 10% 50V	1
C117	J707438P5	CAP CER CL2 1N 10% 50V	1
C118	J707438P5	CAP CER CL2 1N 10% 50V	1
C119	J707438P5	CAP CER CL2 1N 10% 50V	1
C120	J707438P5	CAP CER CL2 1N 10% 50V	1
C121	J707438P5	CAP CER CL2 1N 10% 50V	1
C124	J707438P5	CAP CER CL2 1N 10% 50V	1
0002	L855866P1R0	BD PW., REVISION NO.: 0	1
0009	J708765P2	CONT PIN L=25.4 MM	13
0005 :	K805734G1 :	HANDSET - LS ASM. :	
B001	K805733G1	LOUDSPEAKER ASM	1 SEE: PAGE 3
B002	J709442G1	MICROPHONE ASM	1 SEE: PAGE 4
W001	L855845G1	CABEL ASM	1 SEE: PAGE 4
0002	M906077G1	HANDSET, METALLIZED ASM.	1
0003	J709195P1	FILTER	1
0004	A701648P6	SILICONE RTV	0,001 KG
0005	J706075P1	GROMMET	1
0006	L855842P1	CLAMP, CABLE-	1

CIRCUIT POSITION	COMPONENT ITEM NUMBER	COMPONENT DESCRIPTION	QUANTITY
0007	J709571P1	INSULATION PLATE	1
0008	J709292P1	ADHESIVE PRESSURE TAPE	0,020 M
0009	J709460G1	TERMINAL, SOLDER-	8
0010	J709453P2	TERMINAL, SOLDERLESS-	2
0011	A700136P4	SLVG INS EL D-3.2X0.51 MM	0,090 M

0010 :	M906063G1 :	RETAINER ASM., HANDSET- :	

W001	L855720G1	CABLE ASM	1 SEE: PAGE 4
0002	K805719G1	LOUDSPEAKER ASM	1 SEE: PAGE 4
0003	J709076P1	MAGNET PERM ALNICO	1
0004	A701748P2	TAPE PRESSURE SENSITIVE	0,005 M
0005	J706212P101	SCREW PAN HD SZ 2.0X4.8 MM	4
0006	A700034P3	NUT HEX M-2.5X0.45 MM	4
0007	A702361P306	SCREW PAN HD 2.5X6.0 MM	4
0008	M905925P1	COVER	1
0009	M905889G1	HOUSING ASM	1
0010	J708994P1	FASTENER	2
0013	A701847P101	SCREW PAN HD D-2.2X4.8 MM	2

0001 :	L855628G1 :	KEYBOARD ASM. (DENM./NORW.) :	

0002	M905792P1	PLATE, L E D LIGHT-	1
0003	K805526G1	FOIL, CONTACT-	1
0004	K805539G1	MEMBRANE, CONTACT-RUBBER-	1
0005	M905789P1	FRAME	1
0006	L855562P1	CAP	24
* 0007	* K805752G1	* SHIELD, KEYBOARD-	* 1

0001 :	L855628G2 :	KEYBOARD ASM. (SWED./FINL.) :	

0002	M905792P1	PLATE, L E D LIGHT-	1
0003	K805526G1	FOIL, CONTACT-	1
0004	K805539G2	MEMBRANE, CONTACT-RUBBER-	1
0005	M905789P1	FRAME	1
0006	L855562P1	CAP	24
* 0007	* K805752G1	* SHIELD, KEYBOARD-	* 1

B001 :	K805733G1 :	LOUDSPEAKER ASM., :	

B001	J708678P1	HANDSET REC INSERT, 220R	1
W001	J707179P10	WIRE, STRAND.-'BLACK' 0.055MM	0,060 M
W002	J707179P10	WIRE, STRAND.-'BLACK' 0.055MM	0,060 M

CIRCUIT POSITION	COMPONENT ITEM NO.	COMPONENT DESCRIPTION	QUANTITY
0002	J706286P4	CONNECTOR, PT RECEPT. 47650	2
0003	A700136P3	SLEEVING, INS. EL D-2.0X0.51	0,0125 M
0004	A700136P3	SLEEVING, INS. EL D-2.0X0.51	0,0125 M

B002 :	J709442G1 :	MICROPHONE ASM., :	
B001	A701301P2	MICROPONE CARTRIDGE	1
W001	J707179P2	WIRE,STRAND.-'RED' 0.055MM	0,055 M
W002	J707179P10	WIRE,STRAND.-'BLACK' 0.055MM	0,055 M
0005	J706286P4	CONNECTOR, PT RECEPT. 47650	2
0006	A700136P3	SLEEVING, INS. EL D-2.0X0.51	0,0125 M
0007	A700136P3	SLEEVING, INS. EL D-2.0X0.51	0,0125 M

W001 :	L855845G1 :	CABLE ASM, FOR HANDSET - LS ASM :	
W001	J709341P1	CABLE, MULTI	1
0002	M906062P1	COVER	1
0003	M906061P1	COVER, REAR-	1
0005	J709337P1	HOUSING, CONNECTOR- 5 POS	1
0006	J706286P3	CONNECTOR, PT RECEPTOR-	8
0007	J706286P2	CONNECTOR, PT RECEPTOR-	2
0008	A701847P101	SCREW PAN HD D-2.2 X 4.8 MM	2
0009	L855848P1	CLAMP	1
0010	L855843P1	GROMMET	1

W001 :	L855720G1 :	CABLE ASM, FOR HANDSET RETAINER ASM :	
00A1	L855811G1	JP 6002	1 SEE: PAGE 5
00W1	J708672P6	CABLE, RIBBON- , 06-COND.	0,125 M
00W2	J708672P7	CABLE, RIBBON- , 07-COND.	0,140 M
0002	J706434P3	CONN PWB FEM RECP	13
0007	L855870P1R2	BD PW., REVISION NO.: 2	1

0002 :	K805719G1 :	LOUDSPEAKER ASM, F. HANDSET RETAINER ASM	
00B1	J707712P4	LS, PERM. MAGNET 16R 3W	1
00P1	J706286P4	CONNECTOR, PT RECEPTOR 47650	2

CONTINUED ON LAST PAGE: PAGE 5

31/10/'85

STORNO - DEPT. OF SERVICE CO-ORDINATION

X404.027/4

CIRCUIT POSITION	COMPONENT ITEM NUMBER	COMPONENT DESCRIPTION	QUANTITY
00W1	J707179P10	WIRE,STRAND.-'BLACK' 0.055MM	0.060 M
00W2	J707179P10	WIRE,STRAND.-'BLACK' 0.055MM	0.060 M
0002	A700136P3	SLEEV.G INSUL. EL D-2.4X0.51	0.025 M

00A1 :	L855811G1 :	JP 6002 :	

J101	J708925P1	CONN PT PIN L-9,7 MM	2
J102	J708925P5	CONN PT PIN L-11.7 MM	10
R101	J707385P220	RES MFILM 22R 5% 1/8W	1
R102	J707385P220	RES MFILM 22R 5% 1/8W	1
R103	J707385P220	RES MFILM 22R 5% 1/8W	1
R104	J707385P220	RES MFILM 22R 5% 1/8W	1
R105	J707385P220	RES MFILM 22R 5% 1/8W	1
R106	J707385P220	RES MFILM 22R 5% 1/8W	1
R107	J707385P900	RES MFILM 0R 5% 1/8W JUMP	1
R108	J709456P1	RES MFILM 8R2 5% 1/1W	1
R109	J709456P1	RES MFILM 8R2 5% 1/1W	1
0002	L855812P1R1	BD PW., REVISION NO.: 1	1

CONTROL TYPE	DESCRIPTION
CB6110DR	CB 6110, REMOTE HANDSET W. CONTROL PANEL
CB6110NR	F. STORNOMATIC 6000 - N M T.
CB6110SR	VERSIONS: D/N AND S/Y
CB6110YR	

=====

M A I N P A R T S L I S T :

INDEX-TABLE/ POSIT.-PREFIX	COMPONENT ITEM NO.	COMPONENT DESCRIPTION	QUANTITY	
CB6,02,008 :				
A: 0001	L855630G2	CHASSIS ASM	1	(SEE: BELOW)
A: 0003	K805734G1	HANDSET LS ASM	1	SEE: PAGE 2
0004	K805701P1	SWITCH PTT	1	
0005	K805701P2	SWITCH VOLUME	1	
0006	J709041P1	FASTENER	4	
0007	J706212P201	SCREW PAN HD SZ 4.0X4.8 MM	2	
0008	J709494P1	SPACER	3	
0009	J709293P1	INSULATION FILM	1	
0010	M906063G2	RETAINER ASM., HANDSET-	1	SEE: PAGE 2
CB6,03,003/-,004 :				
A: 0001	L855628G1	KEYBOARD ASM (DENMARK/NORWAY)	1	SEE: PAGE 2
OR :				
A: 0001	L855628G2	KEYBOARD ASM (SWEDEN/FINLAND)	1	SEE: PAGE 3
CB6,04,005 :				
A: 0002	M905980G2	CL 6003 WITH HOOK SWITCH	1	(SEE:- X404.022
A: 0003	K805728G1	AUDIO AMPLIFIER ASM.	1	(SEE:- X404.024
CB6,05,001 :				
0001	J709045P1	LABEL BLANK	1	
0002	J709042P1	LABEL TYPE CB	1	
0004	J709289P1	BOOKLET, USER INSTRUCTION-	1	
0005	J709083P1	BOOKLET, PROGRAM GUIDE-	1	

0001 :	L855630G2 :	CHASSIS ASM. :	
0002	M905785P1	CHASSIS FRONT	1

CIRCUIT POSITION	COMPONENT ITEM NUMBER	COMPONENT DESCRIPTION	QUANTITY
0003	K805526G1	FOIL, CONTACT-	1
0004	K805539G1	MEMBRANE, CONTACT-RUBBER-	1
0005	M905789P1	FRAME	1
0006	L855562P1	CAP	24
* 0007	* K805752G1	* SHIELD, KEYBOARD-	* 1

0001 :	L855628G2 :	KEYBOARD ASM. (SWED./FINL.) :	

0002	M905792P1	PLATE, L E D LIGHT-	1
0003	K805526G1	FOIL, CONTACT-	1
0004	K805539G2	MEMBRANE, CONTACT-RUBBER-	1
0005	M905789P1	FRAME	1
0006	L855562P1	CAP	24
* 0007	* K805752G1	* SHIELD, KEYBOARD-	* 1

B001 :	K805733G1 :	LOUDSPEAKER ASM., :	

B001	J708678P1	HANDSET REC INSERT, 220R	1
W001	J707179P10	WIRE, STRAND.-'BLACK' 0.055MM	0,060 M
W002	J707179P10	WIRE, STRAND.-'BLACK' 0.055MM	0,060 M
0002	J706286P4	CONNECTOR, PT RECEPT. 47650	2
0003	A700136P3	SLEEVING, INS. EL D-2.0X0.51	0,0125 M
0004	A700136P3	SLEEVING, INS. EL D-2.0X0.51	0,0125 M

B002 :	J709442G1 :	MICROPHONE ASM., :	

B001	A701301P2	MICROPONE CARTRIDGE	1
W001	J707179P2	WIRE, STRAND.-'RED' 0.055MM	0,055 M
W002	J707179P10	WIRE, STRAND.-'BLACK' 0.055MM	0,055 M
0005	J706286P4	CONNECTOR, PT RECEPT. 47650	2
0006	A700136P3	SLEEVING, INS. EL D-2.0X0.51	0,0125 M
0007	A700136P3	SLEEVING, INS. EL D-2.0X0.51	0,0125 M

W001 :	L855845G1 :	CABLE ASM, FOR HANDSET - LS ASM :	

W001	J709341P1	CABLE, MULTI	1
0002	M906062P1	COVER	1
0003	M906061P1	COVER, REAR-	1
0005	J709337P1	HOUSING, CONNECTOR- 5 POS	1
0006	J706286P3	CONNECTOR, PT RECEPTOR-	8
0007	J706286P2	CONNECTOR, PT RECEPTOR-	2

CIRCUIT POSITION	COMPONENT ITEM NUMBER	COMPONENT DESCRIPTION	QUANTITY
0008	A701847P101	SCREW PAN HD D-2.2 X 4.8 MM	2
0009	L855848P1	CLAMP	1
0010	L855843P1	GROMMET	1

W001 :	L855720G1 :	CABLE ASM, FOR HANDSET RETAINER ASM :	

00A1	L855811G1	JP 6002	1 (SEE BELOW)
00W1	J708672P6	CABLE, RIBBON- , 06-COND.	0,125 M
00W2	J708672P7	CABLE, RIBBON- , 07-COND.	0,140 M
0002	J706434P3	CONN PWB FEM RECP	13
0007	L855870P1R2	BD PW., REVISION NO.: 2	1

0002 :	K805719G1 :	LOUDSPEAKER ASM, F. HANDSET RETAINER ASM	

00B1	J707712P4	LS, PERM. MAGNET 16R 3W	1
00P1	J706286P4	CONNECTOR, PT RECEPTOR 47650	2
00W1	J707179P10	WIRE,STRAND.-'BLACK' 0.055MM	0.060 M
00W2	J707179P10	WIRE,STRAND.-'BLACK' 0.055MM	0.060 M
0002	A700136P3	SLEEV.G,INSUL. EL D-2.4X0.51	0.025 M

0017 :	K805596G1 :	CC 6005 CABLE KIT :	

P001	J708069P214	CONNECTOR FEM	1
P002	A700041P40	CONN,HSC FEM 14 CKT	1
W001	J706156P5	CA .14 CORED	3,50 M
0002	J707787P1	CONN PWB FEM RECP CLIP	14
0003	J706152P5	STRAP RET W BDL D19 NYL	2
0004	J707335P1	CLAMP LOOP 5 MM	1
0005	A700031P405	SCREW PAN HD M-3.0X5.0 MM	1
0006	J708981P1	CONNECTOR	1

00A1 :	L855811G1 :	JP 6002 :	

J101	J708925P1	CONN PT PIN L-9,7 MM	2
J102	J708925P5	CONN PT PIN L-11.7 MM	10

CONTINUED ON LAST PAGE: PAGE 5

CIRCUIT POSITION	COMPONENT ITEM NUMBER	COMPONENT DESCRIPTION	QUANTITY
R101	J707385P220	RES MFILM 22R 5% 1/8W	1
R102	J707385P220	RES MFILM 22R 5% 1/8W	1
R103	J707385P220	RES MFILM 22R 5% 1/8W	1
R104	J707385P220	RES MFILM 22R 5% 1/8W	1
R105	J707385P220	RES MFILM 22R 5% 1/8W	1
R106	J707385P220	RES MFILM 22R 5% 1/8W	1
R107	J707385P900	RES MFILM 0R 5% 1/8W JUMP	1
R108	J709456P1	RES MFILM 8R2 5% 1/1W	1
R109	J709456P1	RES MFILM 8R2 5% 1/1W	1
0002	L855812P1R1	BD PW., REVISION NO.: 1	1

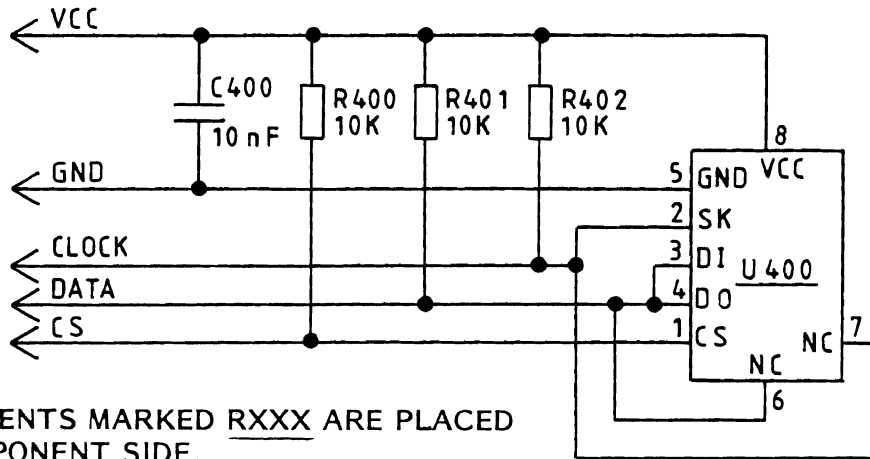

COMPONENTS MARKED RXXX ARE PLACED ON COMPONENT SIDE.

COMPONENT SIDE

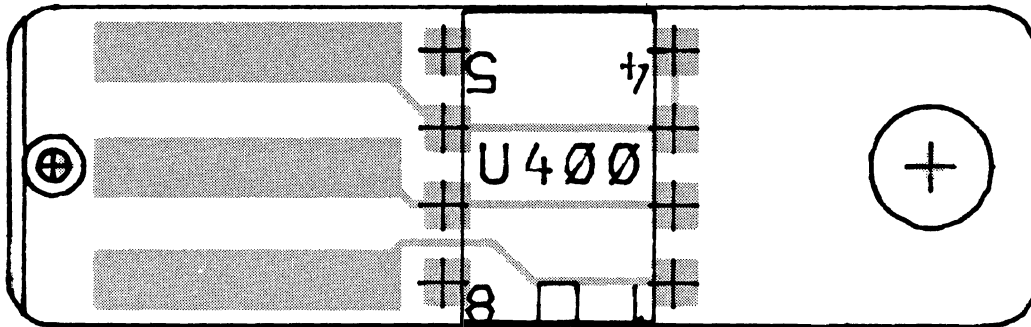

CHIP SIDE

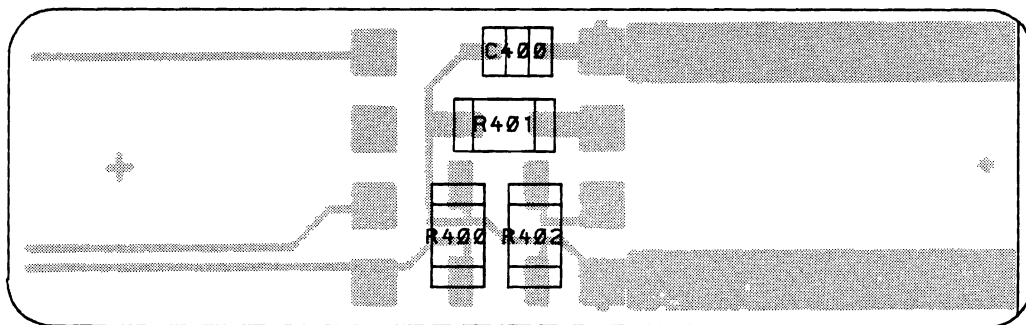

CS6003 - CS6004

EXTERNAL CODE UNIT

The code unit fits inside the JB6002 and interfaces the H-bus.

The code unit consists of a microprocessor which controls the communication between the H-bus and the memory device. It is shielded to avoid noise radiation.

The CS6003/4 is a single PWB which contains the following circuits:

- Microcontroller
- H-bus interface
- Reset circuit
- H-bus address designation
- E2 prom

The difference between CS6003 and CS6004 is the size of the memory:

- CS6003: 16 x 16 bit (256)
- CS6004: 64 x 16 bit (1024)

CIRCUIT DESCRIPTION

MICROCONTROLLER

The central part of the CS module is a 8 bit Nmos microprocessor (8051) in a 40 pin dual in line (U200). The 8051 contains a non-volatile 4 K x 8 read only program memory, a volatile 128 x 8 read/write data memory, 32 I/O lines and on-chip oscillator.

The clock frequency (11.132 MHz) is controlled by a crystal (Y200).

H-BUS INTERFACE

The microprocessor handles the serial communication on the H-bus. The external interface (U201) together with one interrupt and two control lines constitutes the H-bus interface. To make the H-bus insensitive to noise, low pass filters have been inserted on the lines.

RESET CIRCUIT

When the system is turned on it is necessary to reset the microcontroller. This reset pulse is coming on the reset line after the +5 volt supply is turned on in the radio part.

In the delay time between the +5 volt power supply is going on and the reset pulse is coming, C204 is resetting the microcontroller.

H-BUS ADDRESS DESIGNATION

The addressing method is shown on the strap instruction diagram later on in this chapter. Connecting the anode of D203 to one of four points on the board with a strap, will determine which of the four precoded addresses will be used. The CS board is default wired to the highest address.

To change the address it is necessary to cut a wire on the board and strap it to the wanted address

E2 PROM

The personality data in the code unit is stored in a E2 prom. It is possible to change or reprogram this E2 prom with personality data for the individual customer. The E2 prom (U202) is connected to the microprocessor via a serial data line a serial clock line and a chip select.

SPECIFICATIONS

Supply

from the radio: 5 volt \pm 0.2 V

Current drain

150 mA max.

Temperature range

Operating: -25 deg. to +60 deg.

Storage: -40 deg. to +70 deg.

Dimensions

L x W x H: 56 x 37 x 20

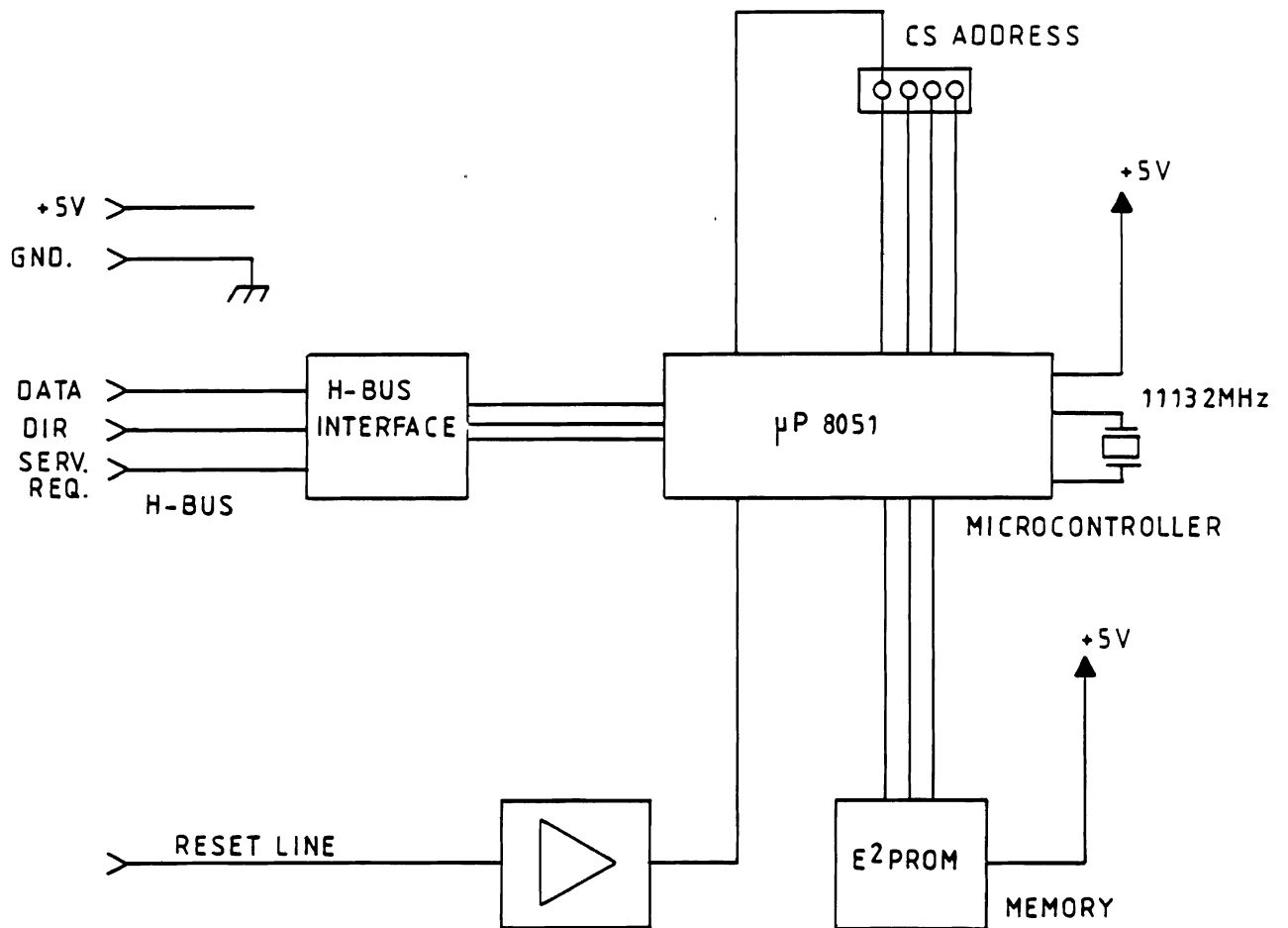

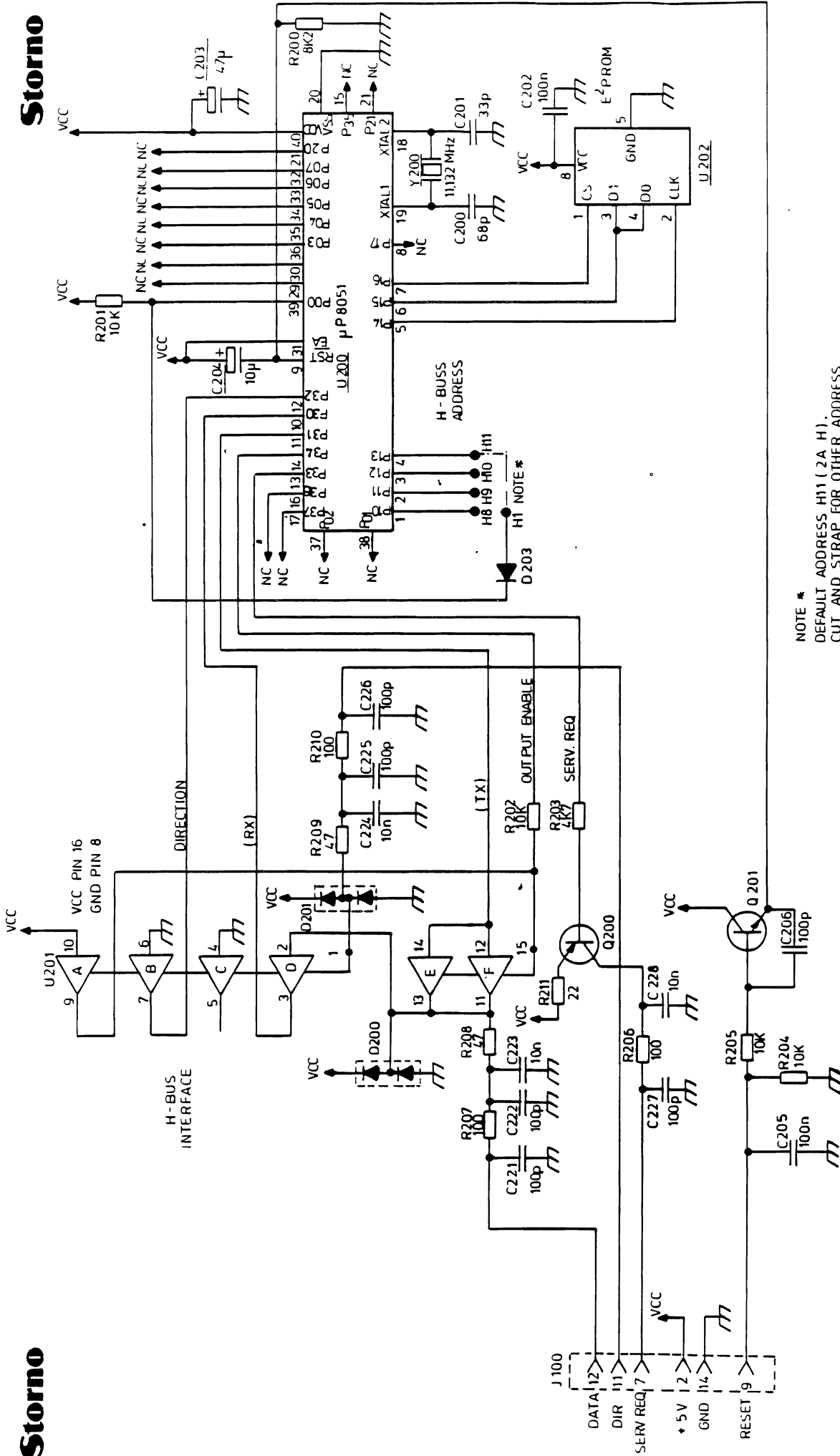

NOTE *
 DEFAULT ADDRESS H11 (2A H1).
 CUT AND STRAP FOR OTHER ADDRESS

COMPONENT MARKED RXXX ARE
 PLACED ON COMPONENT SIDE
 CODE NO. L855909G1 -CS6003
 CODE NO. L855909G2 -CS6004

>>THIS DOCUMENT REMAINS STORNO'S PROPERTY
 AND STORNO RESERVES ALL RIGHTS IN RESPECT
 TO THIS DOCUMENT. WITHOUT STORNO'S WRITTEN
 PERMISSION THE CONTENTS OF THE DOCUMENT
 MUST NOT BE IMPARTED TO A THIRD PARTY NOR
 BE USED FOR ANY UNAUTHORIZED PURPOSE<<<

EXTERNAL CODE UNIT CS6003/4
 D404.333

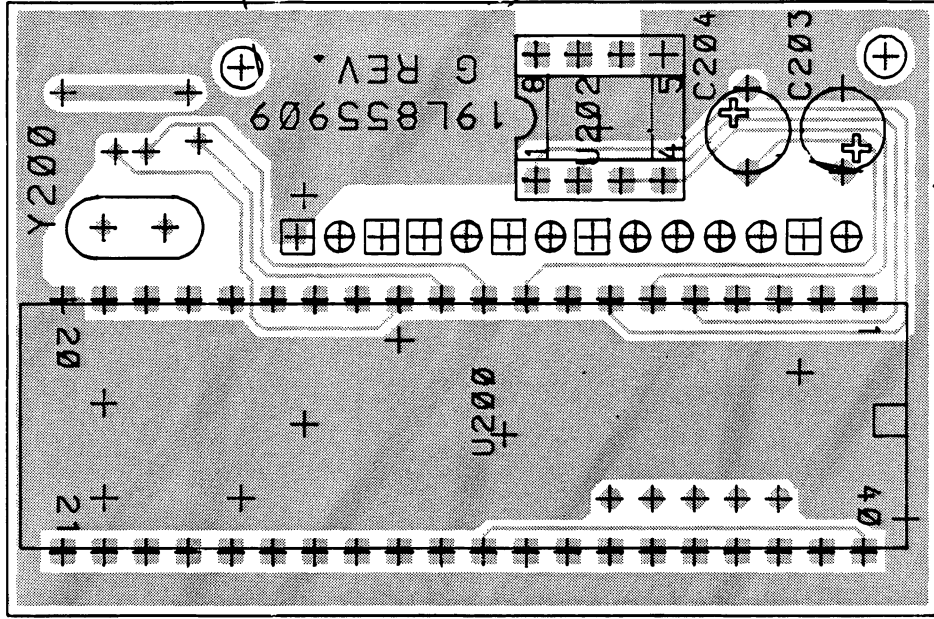
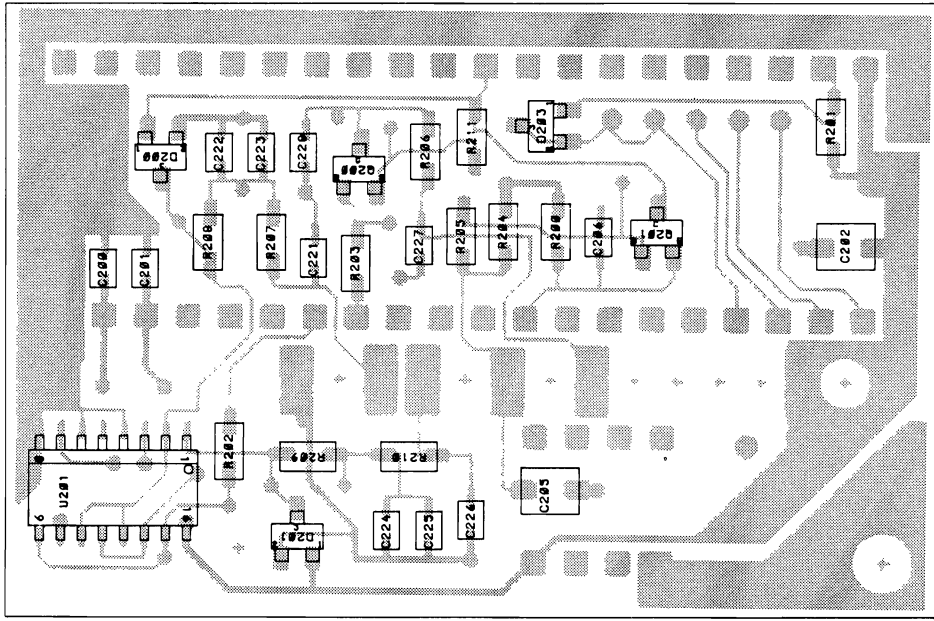

CODE NO. L855909G1-CS6003
CODE NO. L855909G2-CS6004

EXTERNAL CODE UNIT CS6003/4
COMPONENT LAYOUT
COMPONENT SIDE-CHIP SIDE

D404.334

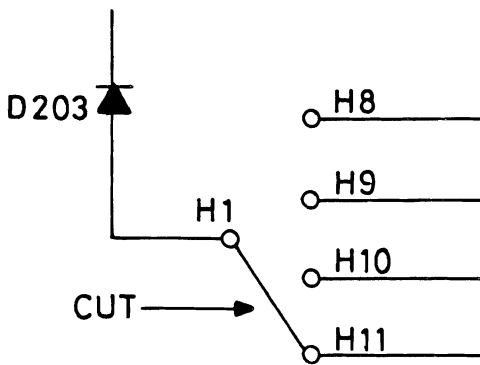
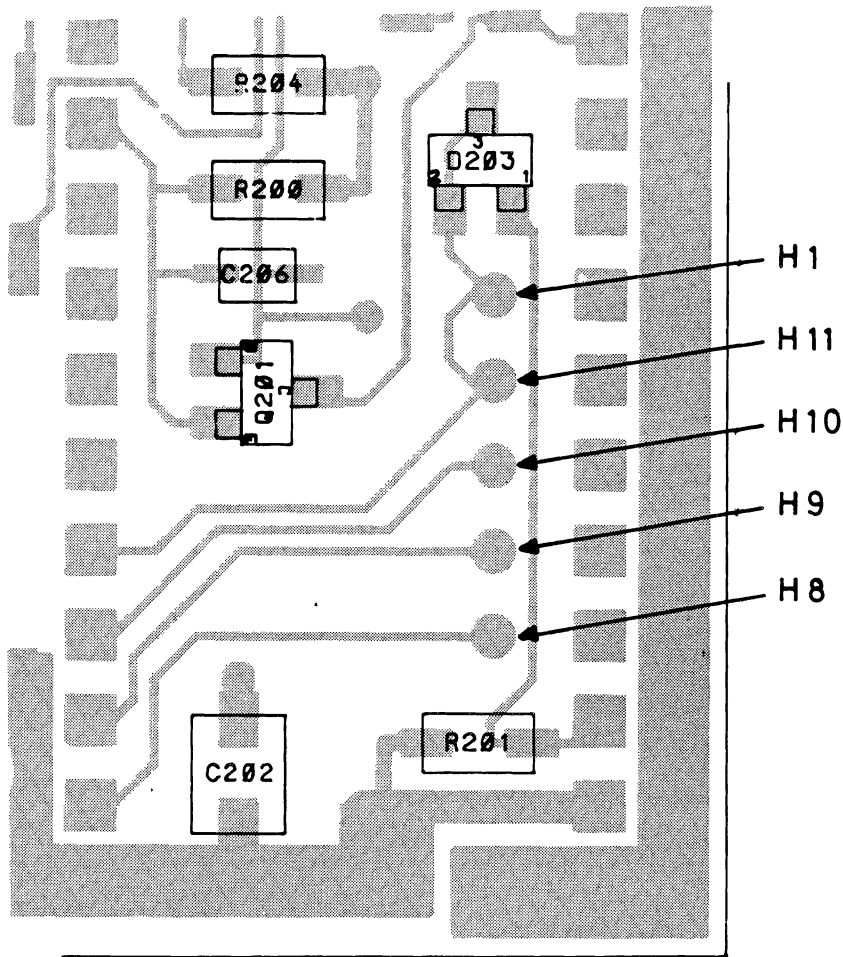

CS ADDRESS	H-BUS ADDRESS
H8	27H
H9	28H
H10	29H
H11	2A H DEFAULT

NOTE :
 DEFAULT ADDRESS (2A H)
 CUT AND STRAP FOR OTHER
 ADDRESS.

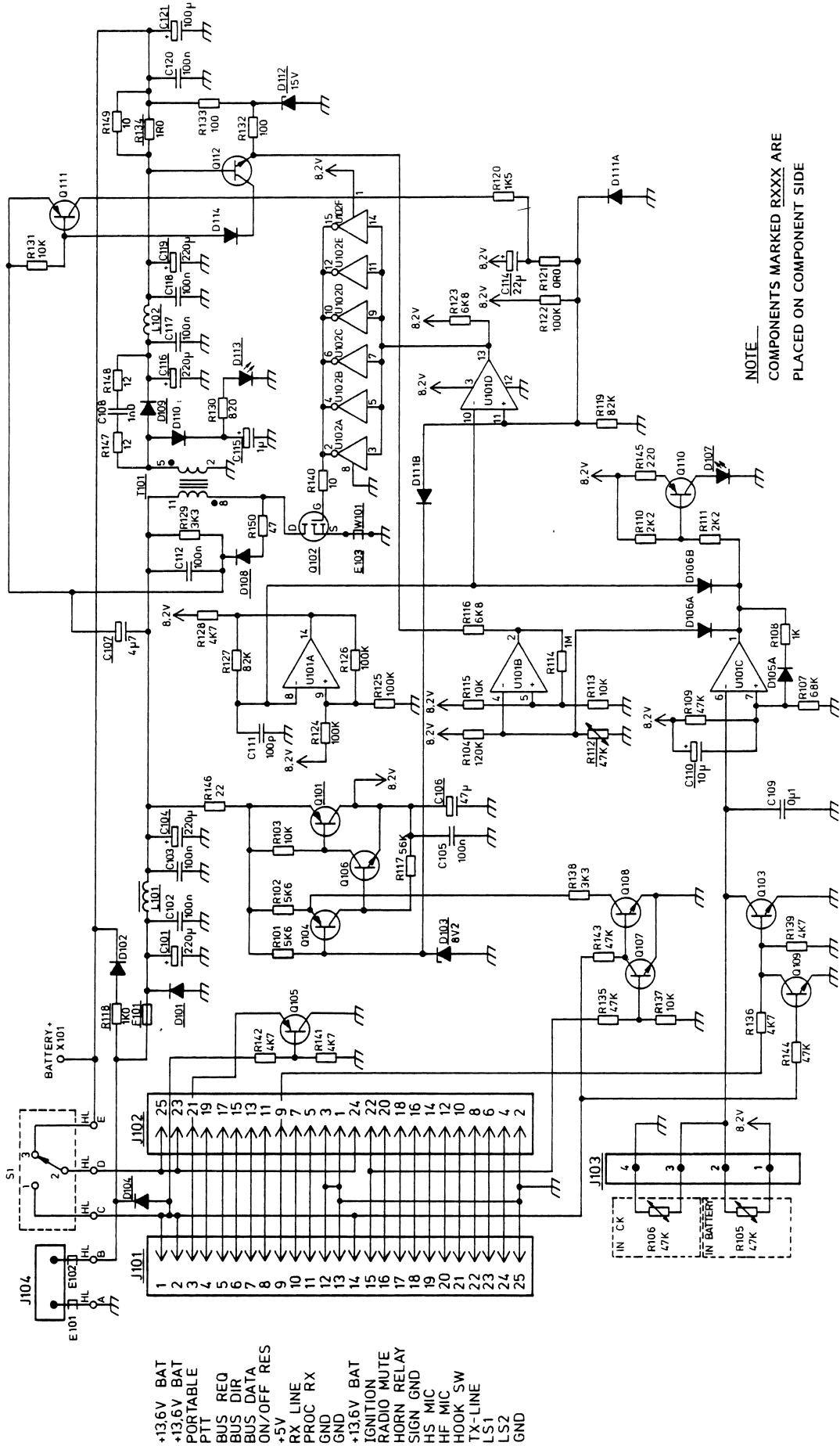

- +13.6V BAT
- +13.6V BAT
- PORTABLE
- PTT
- BUS REQ
- BUS DIR
- BUS DATA
- ON/OFF RES
- +5V
- RX LINE
- PROC RX
- GND
- GND
- +13.6V BAT
- IGNITION
- RADIO MUTE
- HORN RELAY
- SIGN GND
- HS MIC
- HF MIC
- HOOK SW
- TX-LINE
- LS1
- LS2
- GND

NOTE -
COMPONENTS MARKED RXXX ARE
PLACED ON COMPONENT SIDE

Storno

Storno

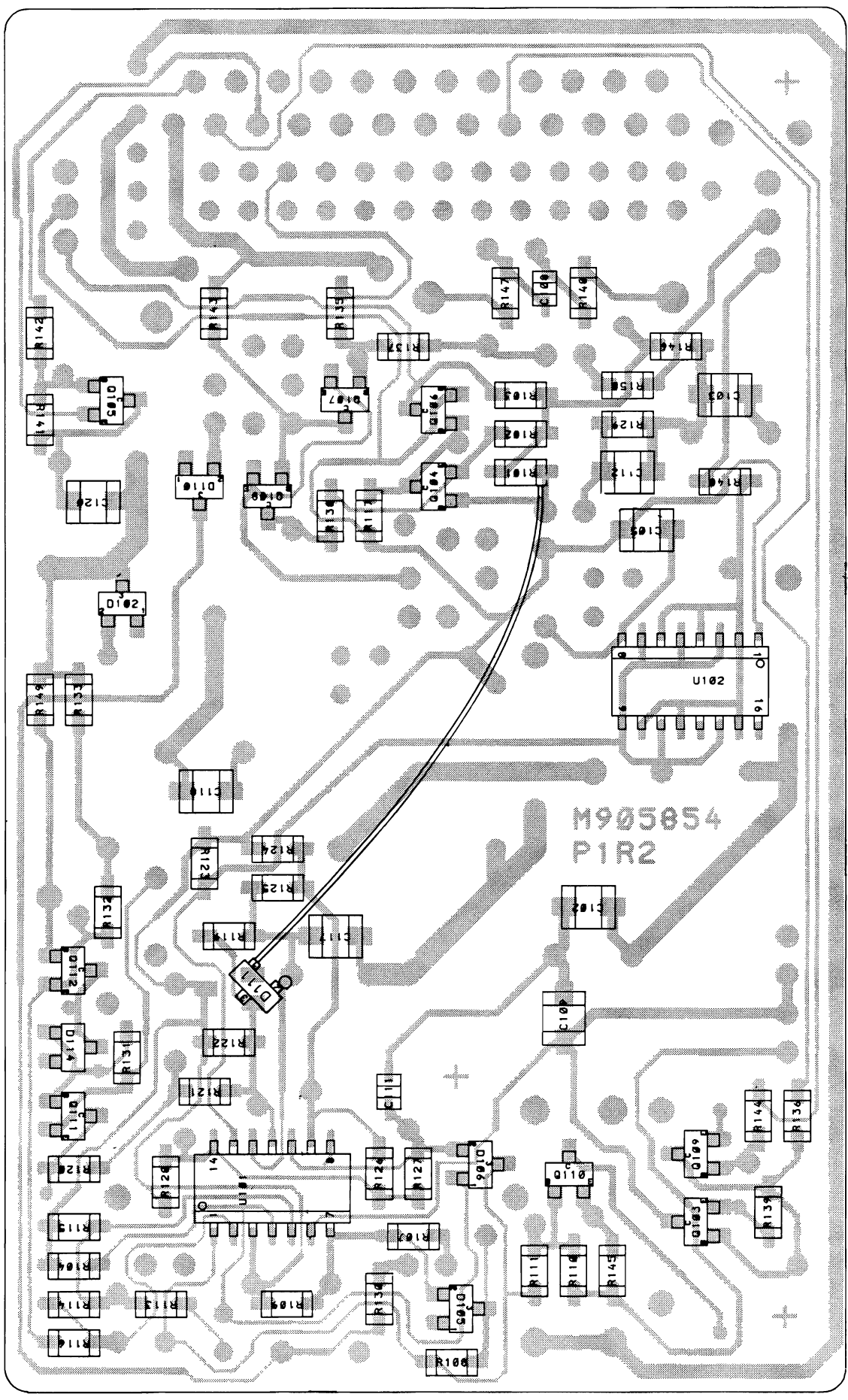

CHARGING UNIT CU6001
COMPONENT LAYOUT CHIP SIDE

D404.260

ITEM NUMBER DESCRIPTION
 K805741G1 CU 6001 ASM., CPNT BD. MNTD W. HEAT SINK
 =====

P A R T S L I S T :

CIRCUIT POSITION	COMPONENT ITEM NUMBER	COMPONENT DESCRIPTION	QUANTITY
A001	M905853G1	CPNT BD CU 6001	1 (SEE BELOW)
* E101	* J707961P2	* CORE, TOR. FERR.- UI 900	* 1
* E102	* J707961P2	* CORE, TOR. FERR.- UI 900	* 1
J101	J708471P3	CONN MULTI RECP 25-WAY	1
J104	J708829P1	CONN POWER RECP 02-WAY	1
Q101	J706890P1	TSTR PNP SI BD 140	1
Q102	J708775P1	TSTR MFET SI BUZ 20	1
S001	A700189P1	SWITCH TOGGLE, 7101G	1
W001	J707210P100	WIRE 0.220 SQ 'BLACK'	0.250 M
0002	A700031P405	SCREW PAN HD M-3.0 X 5.0 MM	2
0003	A700034P4	NUT HEX M-3.0 X 0.50 MM	2
0004	J709304G1	HEAT SINK TEXTED	1
0005	J708766P1	INSULATOR SHEET	1
0006	A700068P1	INS BUSH	1
0007	A700031P306	SCREW PAN HD M-2.5 X 6.0 MM	1
0008	A700034P3	NUT HEX M-2.5 X 0.45 MM	2
0009	J708766P2	INSULATOR	1
0010	A700031P308	SCREW PAN HD M-2.5 X 8.0 MM	1

A001 : M905853G1 : CPNT BD CU 6001 :

C101	J706005P14	CAP ELECT 220U +100-10%	1
C102	J707438P26	CAP CER CL2 100N 10% 50V	1
C103	J707438P26	CAP CER CL2 100N 10% 50V	1
C104	J706005P14	CAP ELECT 220U +100-10%	1
C105	J707438P26	CAP CER CL2 100N 10% 50V	1
C106	J707444P17	CAP TA SOL 47U 20% 10V	1
C107	J707444P6	CAP TA SOL 4U7 20% 35V	1
C108	J707438P5	CAP CER CL2 1N0 10% 50V	1
C109	J707438P26	CAP CER CL2 100N 10% 50V	1
C110	J707444P7	CAP TA SOL 10U 20% 16V	1
C111	J707436P61	CAP CER NPO 100P 5% 50V	1
C112	J707438P26	CAP CER CL2 100N 10% 50V	1
C114	J707444P8	CAP TA SOL 22U 20% 16V	1
C115	J707444P4	CAP TA SOL 1U 20% 35V	1
C116	J706005P10	CAP ELECT 220U +100-10%	1

CIRCUIT POSITION	COMPONENT ITEM NUMBER	COMPONENT DESCRIPTION	QUANTITY
C117	J707438P26	CAP CER CL2 100N 10% 50V	1
C118	J707438P26	CAP CER CL2 100N 10% 50V	1
C119	J706005P10	CAP ELECT 220U +100-10%	1
C120	J707438P26	CAP CER CL2 100N 10% 50V	1
C121	J706005P9	CAP ELECT 100U +100-10%	1
D101	J706100P2	DIO SI SIG 1N4004	1
D102	J707389P1	DIO SI SIG BAV 99	1
D103	A700025P9	DIO SI ZENR 8V2 5% 0,4W	1
D104	J706100P2	DIO SI SIG 1N4004	1
D105	J707389P1	DIO SI SIG BAV 99	1
D106	J707390P1	DIO SI SIG BAV 74	1
D107	J707764P2	DIO LED ESG 5501 , -'GREEN'-	1
D108	A700028P1	DIO SI SIG 1N4148	1
D109	J708734P1	DIO SI PWR BYV 28-100	1
D110	J707389P1	DIO SI SIG BAV 99	1
D111	J707389P1	DIO SI SIG BAV 99	1
D112	J706270P6	DIO SI ZENER 15V0 5% 0,4W	1
D113	J707764P1	DIO LED ESR 5501 , -'RED'-	1
D114	J707389P1	DIO SI SIG BAV 99	1
E103	A700103P1	CORE, FERRITE-	1
F101	J706998P7	FUSE CTG 2.0A SLOW	1
J102	J708925P1	CONN PT PIN L-9,7	26
J103	J708068P4	CONN PWB MALE RECP 04-CKT	1
L101	K805622G1	COIL FILTER	1
L102	K805622G1	COIL FILTER	1
Q103	J707386P1	TSTR NPN SI BCW 32	1
Q104	J707387P1	TSTR PNP SI BCW 30	1
Q105	J707387P1	TSTR PNP SI BCW 30	1
Q106	J707386P1	TSTR NPN SI BCW 32	1
Q107	J707386P1	TSTR NPN SI BCW 32	1
Q108	J707386P1	TSTR NPN SI BCW 32	1
Q109	J707386P1	TSTR NPN SI BCW 32	1
Q110	J707387P1	TSTR PNP SI BCW 30	1
Q111	J707387P2	TSTR PNP SI BCW 70	1
Q112	J707386P2	TSTR NPN SI BCW 72	1
R101	J706056P44	RES DEPC 3K9 5% 1/2W	1
R102	J707385P180	RES MFILM 18R 5% 1/8W	1
R103	J707385P103	RES MFILM 10K 5% 1/8W	1
R104	J707385P124	RES MFILM 120K 5% 1/8W	1
R106	J707406P5	RES THERM NTC 47K 10%	1
R107	J707385P683	RES MFILM 68K 5% 1/8W	1
R108	J707385P102	RES MFILM 1K0 5% 1/8W	1
R109	J707385P473	RES MFILM 47K 5% 1/8W	1
R110	J707385P222	RES MFILM 2K2 5% 1/8W	1
R111	J707385P222	RES MFILM 2K2 5% 1/8W	1
R112	J707406P5	RES THERM NTC 47K 10%	1
R113	J707385P103	RES MFILM 10K 5% 1/8W	1

CIRCUIT POSITION	COMPONENT ITEM NUMBER	COMPONENT DESCRIPTION	QUANTITY
R114	J707385P105	RES MFILM 1M0 10% 1/8W	1
R115	J707385P103	RES MFILM 10K 5% 1/8W	1
R116	J707385P682	RES MFILM 6K8 5% 1/8W	1
R117	J707385P563	RES MFILM 56K 5% 1/8W	1
R118	J706251P37	RES DEPC 1K0 5% 1/1W	1
R119	J707385P823	RES MFILM 82K 5% 1/8W	1
R120	J707385P152	RES MFILM 1K5 5% 1/8W	1
R121	J707385P900	RES MFILM 0R0 5% 1/8W, JUMP.	1
R122	J707385P104	RES MFILM 100K 5% 1/8W	1
R123	J707385P682	RES MFILM 6K8 5% 1/8W	1
R124	J707385P104	RES MFILM 100K 5% 1/8W	1
R125	J707385P104	RES MFILM 100K 5% 1/8W	1
R126	J707385P104	RES MFILM 100K 5% 1/8W	1
R127	J707385P823	RES MFILM 82K 5% 1/8W	1
R128	J707385P472	RES MFILM 4K7 5% 1/8W	1
R129	J707385P332	RES MFILM 3K3 5% 1/8W	1
R130	J707385P821	RES MFILM 820R 5% 1/8W	1
R131	J707385P103	RES MFILM 10K 5% 1/8W	1
R132	J707385P101	RES MFILM 100R 5% 1/8W	1
R133	J707385P101	RES MFILM 100R 5% 1/8W	1
R134	J706056P1	RES DEPC 1R0 5% 1/2W	1
R135	J707385P473	RES MFILM 47K 5% 1/8W	1
R136	J707385P472	RES MFILM 4K7 5% 1/8W	1
R137	J707385P103	RES MFILM 10K 5% 1/8W	1
R138	J707385P332	RES MFILM 3K3 5% 1/8W	1
R139	J707385P472	RES MFILM 4K7 5% 1/8W	1
R140	J707385P100	RES MFILM 10R 5% 1/8W	1
R141	J707385P472	RES MFILM 4K7 5% 1/8W	1
R142	J707385P472	RES MFILM 4K7 5% 1/8W	1
R143	J707385P473	RES MFILM 47K 5% 1/8W	1
R144	J707385P473	RES MFILM 47K 5% 1/8W	1
R145	J707385P221	RES MFILM 220R 5% 1/8W	1
R146	J707385P220	RES MFILM 22R 5% 1/8W	1
R147	J707385P120	RES MFILM 12R 5% 1/8W	1
R148	J707385P120	RES MFILM 12R 5% 1/8W	1
R149	J707385P100	RES MFILM 10R 5% 1/8W	1
R150	J707385P470	RES MFILM 47R 5% 1/8W	1
T101	K805623G1	TRANSFORMER ASM.	1
U101	J708503P1	IC LIN CMPAR LM 239	1
U102	J708356P1	IC DIG BUFR 4049	1
W001	J707195P26	WIRE, BARE COPPER ANNEALED	0.00015 KG
XF01	J708025P1	HOLDER FUSE 5.0X20.0	1
XF02	J708025P1	HOLDER FUSE 5.0X20.0	1
X101	J706848P1	TERMINAL, BRL D=3.18 MM	1
0002	M905854P1R2	BD PW., REVISION NO.: 2	1

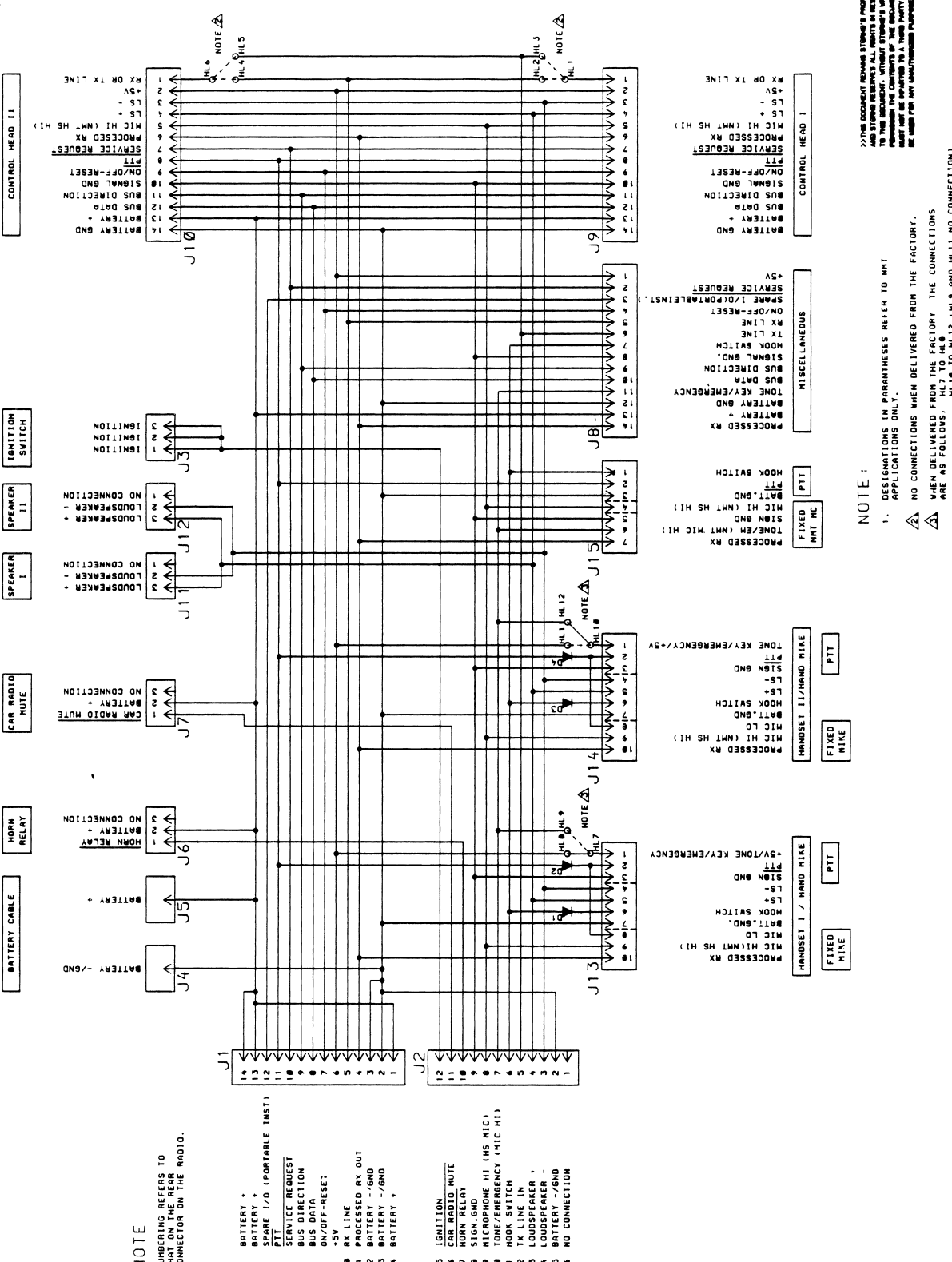

NOTE
 NUMBERING REFERS TO THAT ON THE REAR CONNECTOR ON THE RADIO.

- 1 BATTERY +
- 2 BATTERY -
- 3 SPARE I/O (PORTABLE INST.)
- 4 PTT
- 5 SERVICE REQUEST
- 6 BUS DIRECTION
- 7 BUS DATA
- 8 DN/OFF-RESET
- 9 +5V
- 10 RX LINE
- 11 PROCESSED RX OUT
- 12 BATTERY -/GND
- 13 BATTERY -/GND
- 14 BATTERY +
- 15 IGNITION
- 16 CAR RADIO MUTE
- 17 HORN RELAY
- 18 SIGN-GND
- 19 MICROPHONE III (HS MIC)
- 20 TONE/EMERGENCY (MIC HI)
- 21 HOOK SWITCH
- 22 LOUDSPEAKER +
- 23 LOUDSPEAKER -
- 24 LOUDSPEAKER +
- 25 BATTERY -/GND
- 26 NO CONNECTION

NOTE :
 1. DESIGNATIONS IN PARENTHESES REFER TO MHI APPLICATIONS ONLY.
 △ NO CONNECTIONS WHEN DELIVERED FROM THE FACTORY.
 △ WHEN DELIVERED FROM THE FACTORY THE CONNECTIONS ARE AS FOLLOWS, HL7 TO HL8 (HL9 AND HL11 NO CONNECTION)

>>>THE DOCUMENT REMAINS STORNO'S PROPERTY AND STORNO RESERVES ALL RIGHTS IN RESPECT TO THIS DOCUMENT. WITHOUT STORNO'S WRITTEN PERMISSION THE CONTENTS OF THIS DOCUMENT ARE NOT TO BE REPRODUCED OR TRANSMITTED IN ANY FORM AND UNDER ANY CIRCUMSTANCES.

MOUNTED BOARD CODE NO. M905975G1
 MODULE CODE NO. L855768G1

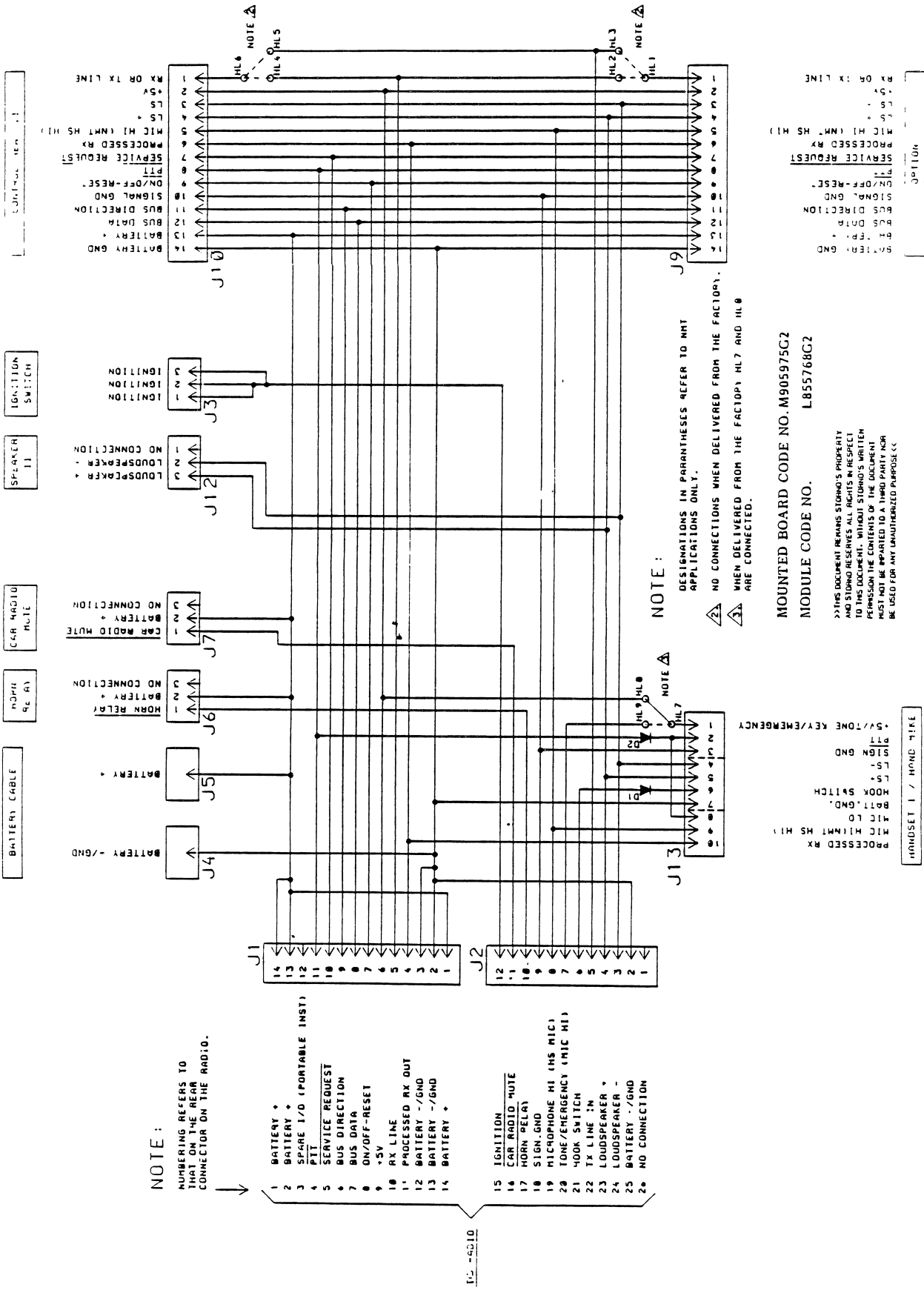

NOTE:
 NUMBERING REFERS TO THAT ON THE REAR CONNECTOR ON THE RADIO.

- 1 BATTERY +
- 2 BATTERY -
- 3 SPARE I/O (PORTABLE INST)
- 4 PTT
- 5 SERVICE REQUEST
- 6 BUS DIRECTION
- 7 BUS DATA
- 8 ON/OFF-RESET
- 9 +5V
- 10 RX LINE
- 11 PROCESSED RX OUT
- 12 BATTERY -/GND
- 13 BATTERY -/GND
- 14 BATTERY +
- 15 IGNITION
- 16 CAR RADIO MUTE
- 17 HORN RELAY
- 18 SIGN.GND
- 19 MICROPHONE HI (MS MIC)
- 20 TONE/EMERGENCY (MIC HI)
- 21 HOOK SWITCH
- 22 TX LINE IN
- 23 LOUDSPEAKER +
- 24 LOUDSPEAKER -
- 25 BATTERY -/GND
- 26 NO CONNECTION

NOTE:
 DESIGNATIONS IN PARENTHESES REFER TO MNT APPLICATIONS ONLY.
 NO CONNECTIONS WHEN DELIVERED FROM THE FACTORY.
 WHEN DELIVERED FROM THE FACTORY HIL7 AND HIL8 ARE CONNECTED.

MOUNTED BOARD CODE NO. M905975C2
 MODULE CODE NO. L855768C2

THIS DOCUMENT REMAINS STORNO'S PROPERTY AND STORNO RESERVES ALL RIGHTS IN RESPECT OF THIS DOCUMENT. WITHOUT STORNO'S WRITTEN PERMISSION NO PART OF THIS DOCUMENT MUST NOT BE REPRODUCED OR TRANSMITTED IN ANY FORM OR BY ANY MEANS, ELECTRONIC OR MECHANICAL, INCLUDING PHOTOCOPYING, RECORDING, OR BY ANY INFORMATION STORAGE AND RETRIEVAL SYSTEM. THIS DOCUMENT IS INTENDED FOR USE ONLY FOR THE PURPOSES SPECIFIED IN THE TITLE AND SHOULD NOT BE USED FOR ANY UNAUTHORIZED PURPOSES.

Storno

Storno

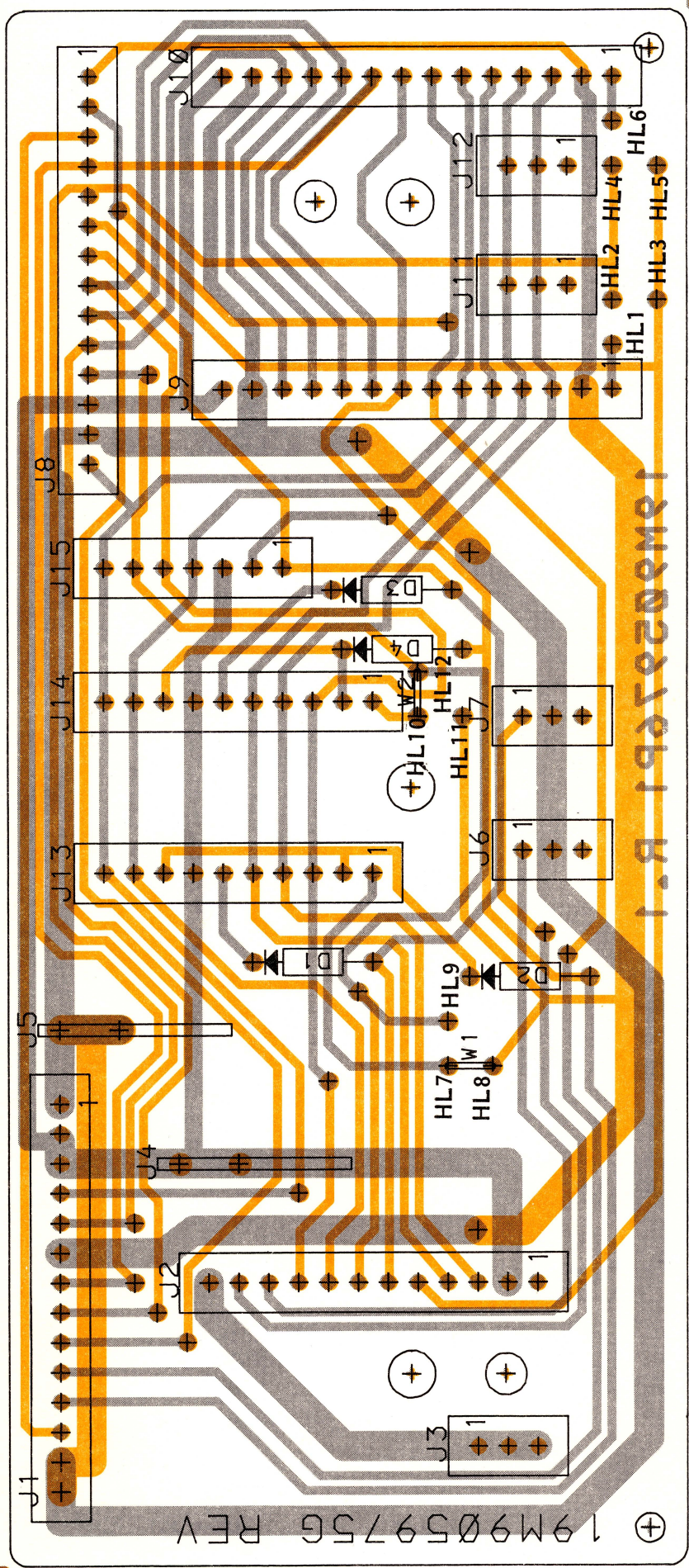

NOTE:
 D3, D4, J8, J11, J14, J15 AND
 W2 ONLY IN G1

MOUNTED BOARD CODE NO. M905975G1 } JB6001
 MODULE CODE NO. L855768G1

MOUNTED BOARD CODE NO. M905975G2 } JB6002
 MODULE CODE NO. L855768G2

JUNCTION BOX JB6001/2
 COMPONENT LAYOUT

REV 1 D404.155/2

ITEM NUMBER	DESCRIPTION
L855768G1	JB 6001
L855768G2	JB 6002

=====

P A R T S L I S T :

CIRCUIT POSITION	COMPONENT ITEM NUMBER	COMPONENT DESCRIPTION	QUANTITY
A001	M905975G1	CPNT BD PW	1 (SEE
A001	M905975G2	CPNT BD PW	1 BELOW)
0003	K805073P1	GASKET	2
0004	A701507P612	SCREW PAN HD SZ3.5X19.1AB	2
0005	J706212P203	SCREW PAN HD SZ 4.0X7.9 MM	2
0006	J706285P1	LOCKING RING	1
0007	J706307P37	NAMEPLATE JB6001	1 G1
0007	J706307P70	NAMEPLATE JB6002	1 G2
0010	A700031P635	SCREW PAN HD M-4.0X35.0 MM	1
0011	J709152P1	FOAM	1
0013	K805085G1	ASM CASE	1
0014	L855103P1	COVER	1

A001 : M905975G1 : CPNT BD PW., F. JB 6001 :
A001 : M905975G2 : CPNT BD PW., F. JB 6002 :

D001	A700028P1	DIO SI SIG 1N4148	1
D002	A700028P1	DIO SI SIG 1N4148	1
D003	A700028P1	DIO SI SIG 1N4148	1 G1
D004	A700028P1	DIO SI SIG 1N4148	1 G1
J001	J708925P1	CONN PT PIN L=9,7 -14 PINS	1
J002	J708925P1	CONN PT PIN L=9,7 -12 PINS	1
J003	J708925P1	CONN PT PIN L=9,7 - 3 PINS	1
J004	J708100P2	TERM TAB SPADE	1
J005	J708100P2	TERM TAB SPADE	1
J006	J708925P1	CONN PT PIN L=9,7 - 3 PINS	1
J007	J708925P1	CONN PT PIN L=9,7 - 3 PINS	1
J008	J708925P1	CONN PT PIN L=9,7 -12 PINS	1 G1
J009	J708925P1	CONN PT PIN L=9,7 -14 PINS	1 G1
J009	J708925P6	CONN PT PIN L=16,0-14 PINS	1 G2
J010	J708925P1	CONN PT PIN L=9,7 -14 PINS	1
J011	J708925P1	CONN PT PIN L=9,7 - 3 PINS	1 G1
J012	J708925P1	CONN PT PIN L=9,7 - 3 PINS	1
J013	J708925P1	CONN PT PIN L=9,7 -10 PINS	1
J014	J708925P1	CONN PT PIN L=9,7 -10 PINS	1 G1
J015	J708925P1	CONN PT PIN L=9,7 - 7 PINS	1 G1

0002 M905976P1R1 BD PW., REVISION NO.: 1 1

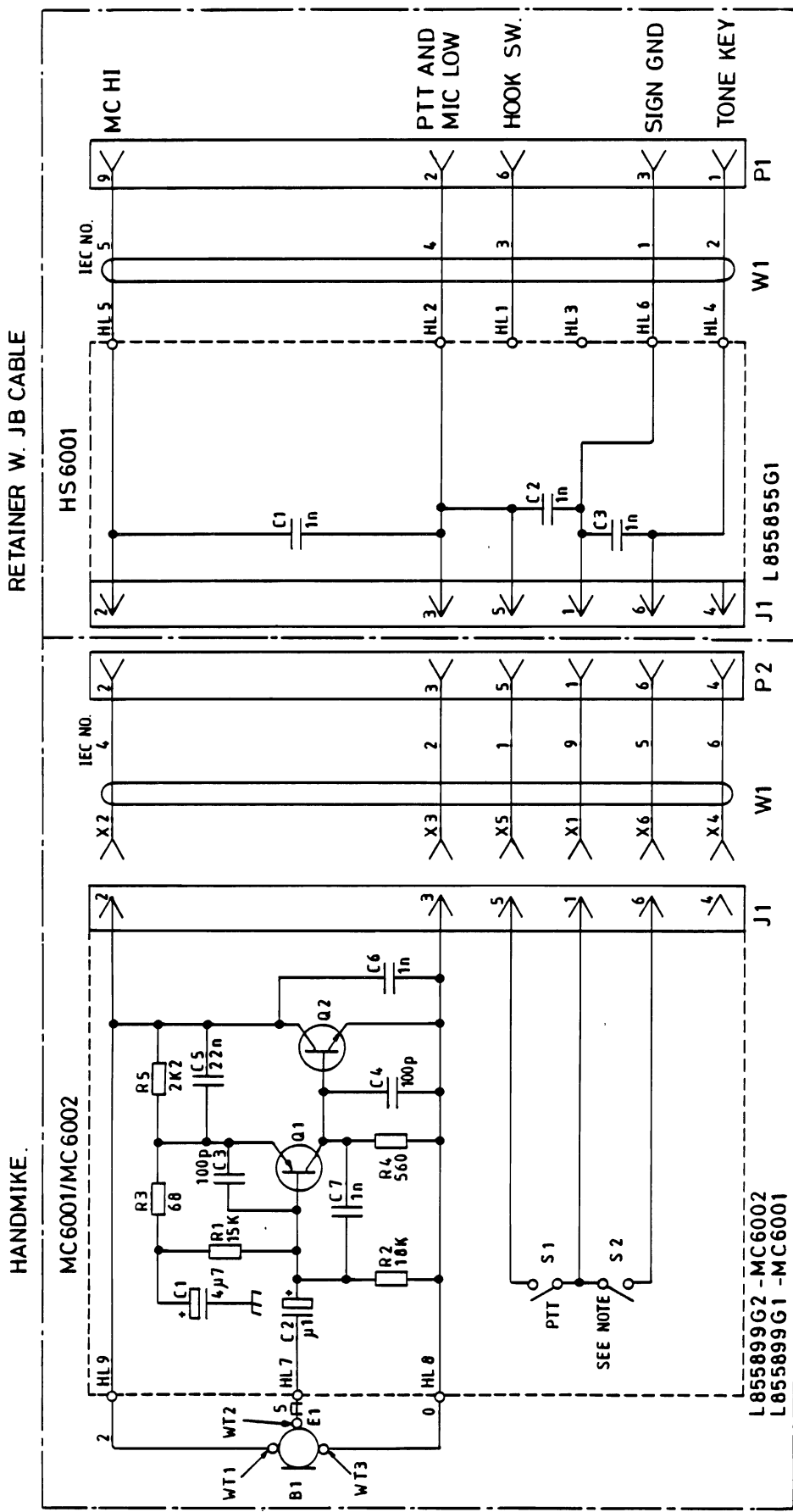

NOTE :
 1. S2 IS ONLY MOUNTED IN HANDMIKE MC6002.

MICROPHONE WITH SUPPORT
 MC6001/2 AND HS6001
 D404.121/2

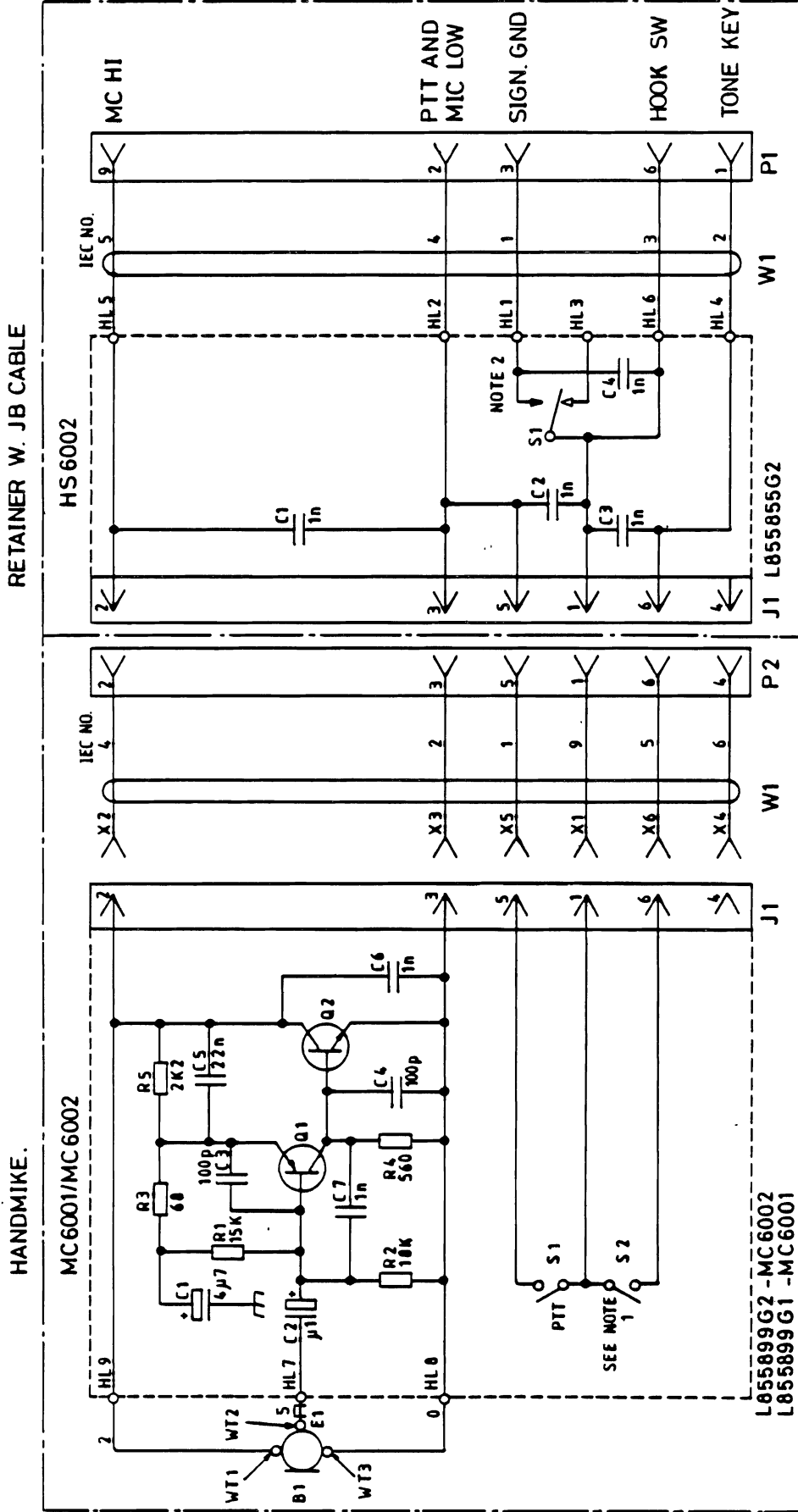

MICROPHONE WITH SUPPORT
MC6001/2 AND HS6002

D404.122/2

Storno

Storno

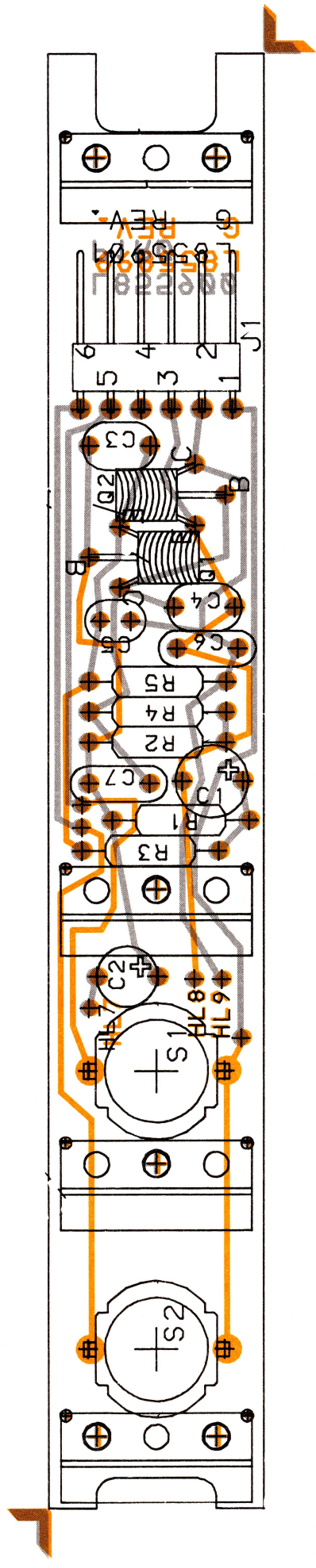

CODE NO. L.855899G2-MC6002

CODE NO. L.855899G1-MC6001

MICROPHONE MC6001 AND MC6002
COMPONENT LAYOUT

D404.332

ITEM NUMBER	DESCRIPTION
L855903G4	MC 6001
=====	
L855904G4	SUB ASM : CHASSIS ASM F. MC 6001
L855899G1	SUB-SUB ASM : CPNT BD, F.MC901 / MC6001

P A R T S L I S T :

CIRCUIT POSITION	COMPONENT ITEM NUMBER	COMPONENT DESCRIPTION	QUANTITY
A001	L855904G4	CHASSIS ASM, F. MC 6001	1 (SEE BELOW)
B001	J706041P1	MICROPH. CARTRIDGE E M 60	1
E001	A700103P1	FERR CORE	1
W001	K805029G1	CABLE ASM, COILED CORD-	1
0003	K805098G3	HOUSING ASM., F.MC901/MC600X	1
0004	K805057P1	HOLDER, RUBBER-	1
0005	J706119P1	SCREEN	1
0006	K805058P2	CLAMP, STRAIN RLF-	1
0007	J706181P406	SCREW M4X6 NYLON	1
0010	A701268P2	WIRE, "RED"	0,1 M
0011	A701268P10	WIRE, "BLACK"	0,1 M
0012	A701268P5	WIRE, "GREEN"	0,1 M
0016	A700031P208	SCREW PAN HD M-2.0 X 8.0MM	2
0019	J708323P1	PROTECTOR	1
/-----/			

A001 : L855904G4 : CHASSIS ASM F. MC 6001 :

A001	L855899G1	CPNT BD PW, F.MC 901/MC6001	1 (SEE BELOW)
0003	K805177P1	CAP, BUTTON- "GREEN"	1
0004	L855184P1	BUTTON, 'BLACK'	1
0006	J706120P1	TEXTPLATE	1
0013	J709467G1	CHASSIS, COATED	1
0020	A700031P206	SCREW PAN HD M-2.0 X 6.0MM	5
0021	J709470P1	PLATE	1
0022	J709472P1	FOAM ACTUATOR	1
0023	J709471P4	NAMEPLATE, 'MC 6001'	1

A001 : L855899G1 : CPNT BD. PW F. MC 901 / MC 6001 :

C001	A701534P6	CAP TA SOL 4U7 20% 35V	1
C002	A701534P1	CAP TA SOL 0U1 20% 35V	1
C003	A700233P1	CAP CER CL2 100P 20% 50V	1

27/09/'85

STORNO - DEPT. OF SERVICE CO-ORDINATION

X404.219

JEV

CIRCUIT POSITION	COMPONENT ITEM NUMBER	COMPONENT DESCRIPTION	QUANTITY
C004	A700233P1	CAP CER CL2 100P 20% 50V	1
C005	A700121P3	CAP CER 22N 20% 50V	1
C006	A700233P7	CAP CER CL2 1N0 20% 50V	1
C007	A700233P7	CAP CER CL2 1N0 20% 50V	1
J001	A700072P226	CONN PWB MALE 06 CKT	1
Q001	A700020P1	TSTR PNP SI BC558A/B	1
Q002	A700017P1	TSTR NPN SI BC548A/B	1
R001	A700019P51	RES DEPC 15K 5% 1/4W	1
R002	A700019P52	RES DEPC 18K 5% 1/4W	1
R003	A700019P23	RES DEPC 68R 5% 1/4W	1
R004	A700019P34	RES DEPC 560R 5% 1/4W	1
R005	A700019P41	RES DEPC 2K2 5% 1/4W	1
S001	J709484P1	SWITCH, MICRO-	1
0002	L855900P1R0	BOARD PW, REVISION NO.: 0	1
0005	J709469G1	SPACER, COATED	3

ITEM NUMBER	DESCRIPTION
L855903G5	MC 6002
=====	
L855904G5	SUB ASM : CHASSIS ASM F. MC 6002
L855899G2	SUB-SUB ASM : CPNT BD, F.MC902 / MC6002

P A R T S L I S T :

CIRCUIT POSITION	COMPONENT ITEM NUMBER	COMPONENT DESCRIPTION	QUANTITY
A001	L855904G5	CHASSIS ASM, F. MC 6002	1 (SEE BELOW)
B001	J706041P1	MICROPH. CARTRIDGE E M 60	1
E001	A700103P1	FERR CORE	1
W001	K805029G1	CABLE ASM, COILED CORD-	1
0003	K805098G3	HOUSING ASM., F.MC901/MC600X	1
0004	K805057P1	HOLDER, RUBBER-	1
0005	J706119P1	SCREEN	1
0006	K805058P2	CLAMP, STRAIN RLF-	1
0007	J706181P406	SCREW M4X6 NYLON	1
0010	A701268P2	WIRE, "RED"	0,1 M
0011	A701268P10	WIRE, "BLACK"	0,1 M
0012	A701268P5	WIRE, "GREEN"	0,1 M
0016	A700031P208	SCREW PAN HD M-2.0 X 8.0MM	2
0019	J708323P1	PROTECTOR	1
/-----/			

A001 : L855904G5 : CHASSIS ASM F. MC 6002 :

A001	L855899G2	CPNT BD PW, F.MC 902/MC6002	1 (SEE BELOW)
0003	K805177P1	CAP, BUTTON- "GREEN"	2
0004	L855184P1	BUTTON, 'BLACK'	2
0006	J706120P1	TEXTPLATE	1
0007	J706120P1	TEXTPLATE	1
0013	J709467G1	CHASSIS, COATED	1
0020	A700031P206	SCREW PAN HD M-2.0 X 6.0MM	6
0021	J709470P1	PLATE	2
0022	J709472P1	FOAM ACTUATOR	2
0023	J709471P5	NAMEPLATE, 'MC 6002'	1

A001 : L855899G2 : CPNT BD. PW F. MC 902 / MC 6002 :

C001	A701534P6	CAP TA SOL 4U7 20% 35V	1
C002	A701534P1	CAP TA SOL 0U1 20% 35V	1

CIRCUIT POSITION	COMPONENT ITEM NUMBER	COMPONENT DESCRIPTION	QUANTITY
C003	A700233P1	CAP CER CL2 100P 20% 50V	1
C004	A700233P1	CAP CER CL2 100P 20% 50V	1
C005	A700121P3	CAP CER 22N 20% 50V	1
C006	A700233P7	CAP CER CL2 1N0 20% 50V	1
C007	A700233P7	CAP CER CL2 1N0 20% 50V	1
J001	A700072P226	CONN PWB MALE 06 CKT	1
Q001	A700020P1	TSTR PNP SI BC558A/B	1
Q002	A700017P1	TSTR NPN SI BC548A/B	1
R001	A700019P51	RES DEPC 15K 5% 1/4W	1
R002	A700019P52	RES DEPC 18K 5% 1/4W	1
R003	A700019P23	RES DEPC 68R 5% 1/4W	1
R004	A700019P34	RES DEPC 560R 5% 1/4W	1
R005	A700019P41	RES DEPC 2K2 5% 1/4W	1
S001	J709484P1	SWITCH, MICRO-	1
S002	J709484P1	SWITCH, MICRO-	1
0002	L855900P1R0	BOARD PW, REVISION NO.: 0	1
0005	J709469G1	SPACER, COATED	4

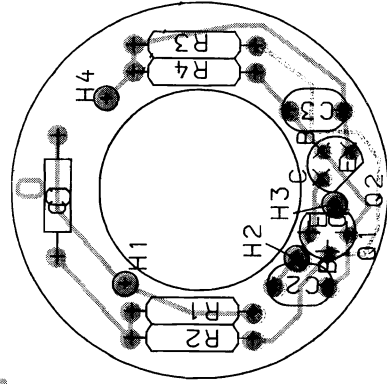
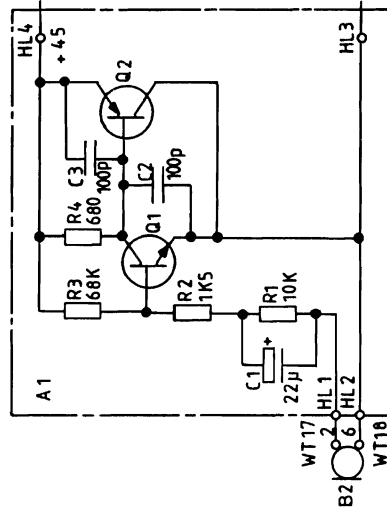
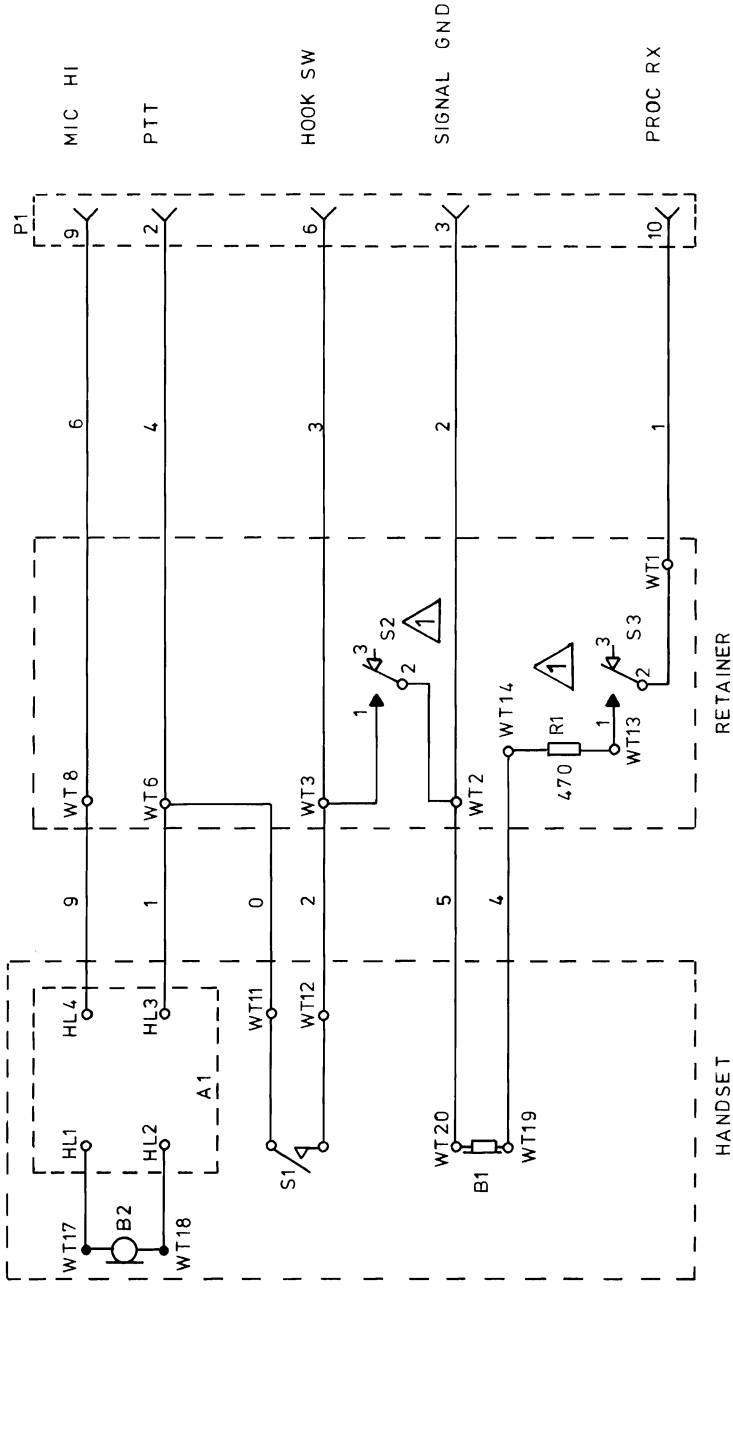

COLOR CODE IEC 304	
0	BLACK
1	BROWN
2	RED
3	ORANGE
4	YELLOW
5	GREEN
6	BLUE
7	VIOLET
8	GREY
9	WHITE

NOTE:
 S2 AND S3 SHOWN WITH HANDSET
 IN RETAINER.
 IEC 304 COLOR CODES ON WIRES.

HANDSET MT6001
 AND RETAINER CONNECTIONS
 D404.217

ITEM NUMBER	DESCRIPTION
M905140G2	MT 6001 , MICRO TELEPHONE HANDSET
K805070G1	SUB ASM.: ASM BD PW F. MT 600X / C9MT0X
J706182P1	SUB ASM.: SPIRAL CABLE ASM. 06 COND.
K805030G2	SUB ASM.: CABLE ASM F. MT 6001

P A R T S L I S T :

CIRCUIT POSITION	COMPONENT ITEM NUMBER	COMPONENT DESCRIPTION	QUANTITY	
A001	K805070G1	ASM BD PW., F. MT600X / C9MT0X	1	(SEE BELOW)
B001	J706194P1	MICROPHONE INS 400R	1	
B002	J706194P1	MICROPHONE INS 400R	1	
R001	A700019P33	RES DEPC 470R 5% 1/4W	1	
W001	J706182P1	SPIRAL CABLE ASM., 06 COND.	1	
W002	K805030G2	CABLE ASM., F. MT 6001	1	SEE: PAGE 2
0002	J706073P1	NETTING	2	
0003	L855026P1	HOLDER	2	
0004	J706074P1	PLATE	1	
0005	J706195P1	CASE, HANDSET- 'BLACK'	1	
0006	A701268P6	WIRE, 'BLUE'	0,025 M	
0007	A701268P2	WIRE, 'RED'	0,025 M	
0008	J706195P2	STOWACE FOR 2 SWITCHES	1	
0009	J706202P5	NAME PLATE: -MT 6001'	1	
0010	A701507P108	SCREW PAN HD SZ4.8X12.7AB	4	
0013	A701268P8	WIRE, 'GREY'	0,12 M	
0014	A701268P4	WIRE, 'YELLOW'	0,08 M	
0016	A701268P2	WIRE, 'RED'	0,15 M	
0017	A701268P5	WIRE, 'GREEN'	0,14 M	
0019	J706075P1	GROMMET	1	
0020	K805023P1	GROMMET	1	
0021	J706313P1	RIVET TUBR D=6.0MM, L=9.0MM	2	
0022	J706433P1	TAPE ACET WDH=12.7MM	0,10 M	
0023	J707335P3	CLAMP LOOP 8 MM	1	

A001 : K805070G1 : ASM BD PW. F. MT 600X / C9MT0X :

C001	B800650P21	CAP TA SOL 2U2 20% 15V	1
C002	A700233P1	CAP CER CL2 100P 20% 50V	1
C003	A700233P1	CAP CER CL2 100P 20% 50V	1
Q001	A700017P1	TSTR NPN SI BC 548A/B	1
Q002	A700020P1	TSTR PNP SI BC558A/B	1

CIRCUIT POSITION	COMPONENT ITEM NUMBER	COMPONENT DESCRIPTION	QUANTITY
R001	A700019P49	RES DEPC 10K 5% 1/4W	1
R003	A700019P57	RES DEPC 47K 5% 1/4W	1
R004	A700019P35	RES DEPC 680R 5% 1/4W	1
W001	A700184P1	RES WIRE JMPR	1
0002	L855097P1R0	BD PW., REVISION NO.: 0	1

W002 :	K805030G2 :	CABLE ASM F. MT 6001 :	
P001	J708069P210	CONNECTOR, FEMALE-	1
0002	J706152P5	STRAP RET W BDL D19 NYL	1
0003	J706156P2	CABLE	2,5 M

Storno

Storno

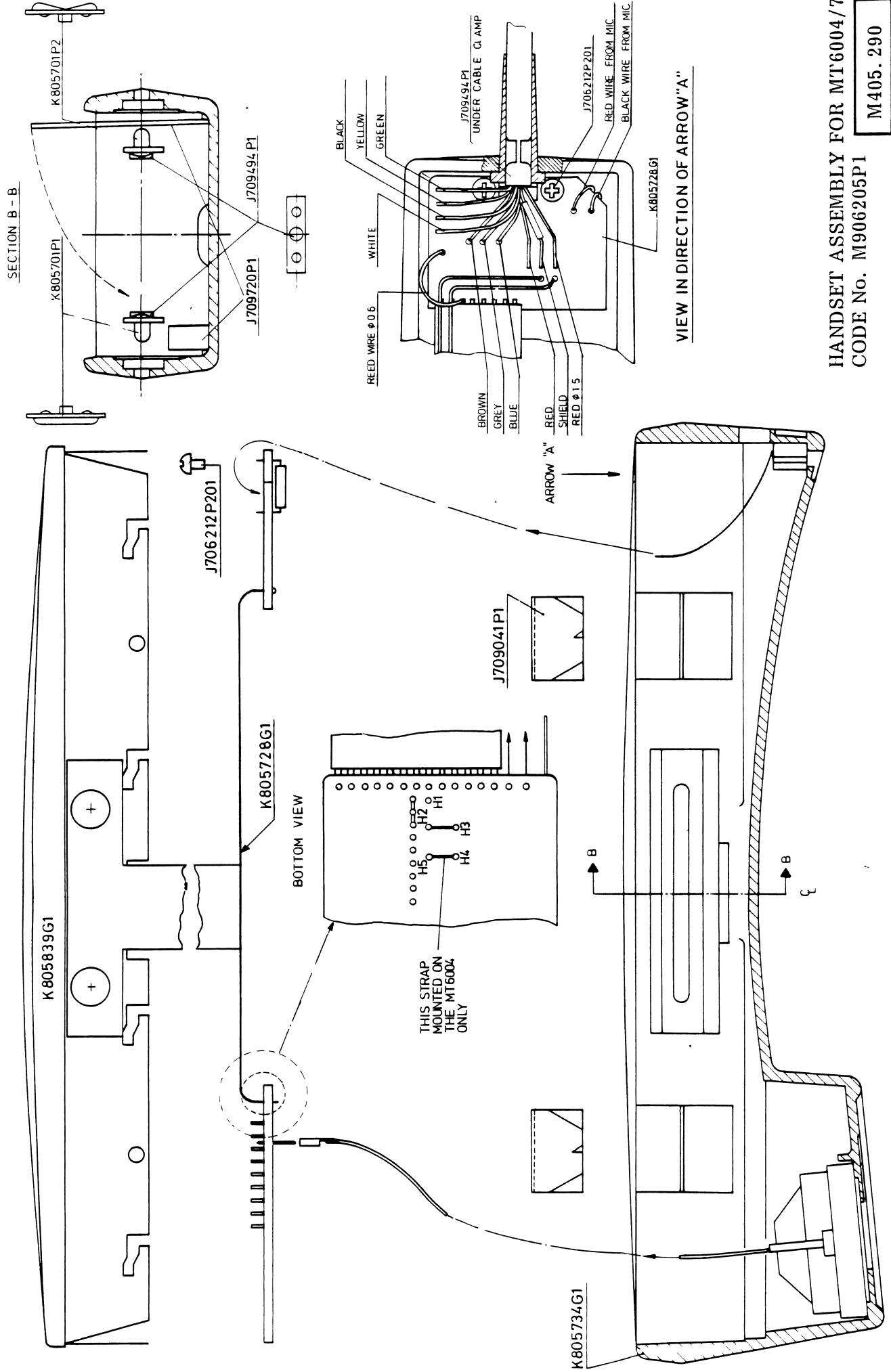

HANDSET ASSEMBLY FOR MT6004/7
 CODE NO. M906205P1

M405.290

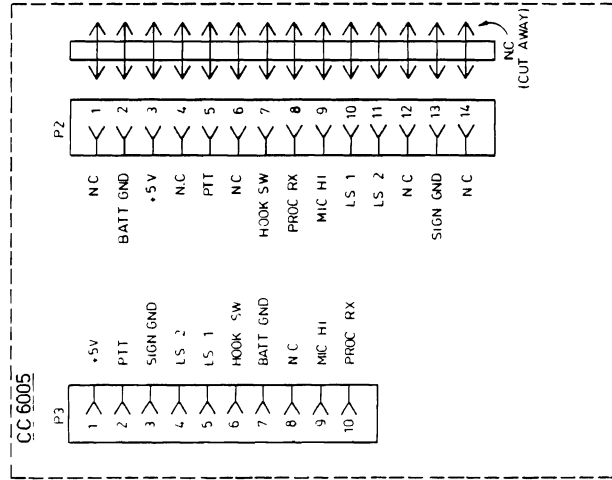
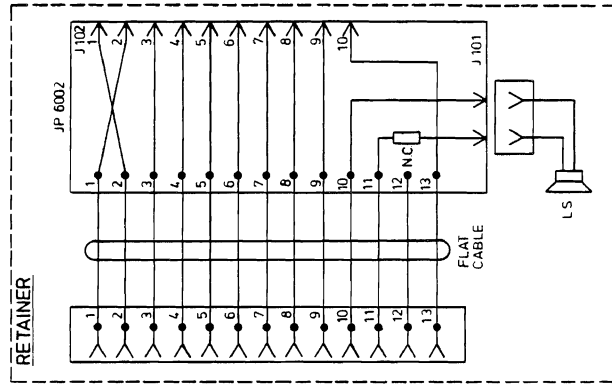
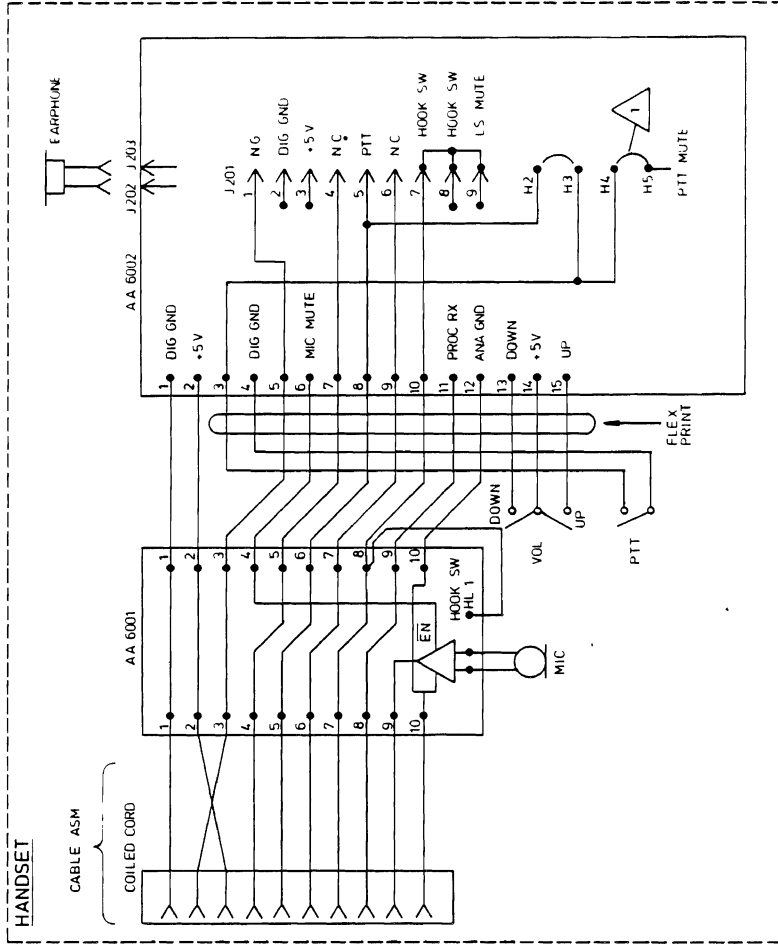

CONNECTED IN THE MT6004 ONLY
(DUPLEX VERSION)



>> THIS DOCUMENT REMAINS STORNO'S PROPERTY AND STORNO RESERVES ALL RIGHTS IN RESPECT TO THIS DOCUMENT. WITHOUT STORNO'S WRITTEN PERMISSION THE CONTENTS OF THE DOCUMENT MUST NOT BE IMPARTED TO A THIRD PARTY NOR BE USED FOR ANY UNAUTHORIZED PURPOSE <<

INTERCONNECTION DIAGRAM FOR MT6004/6007

D404.459

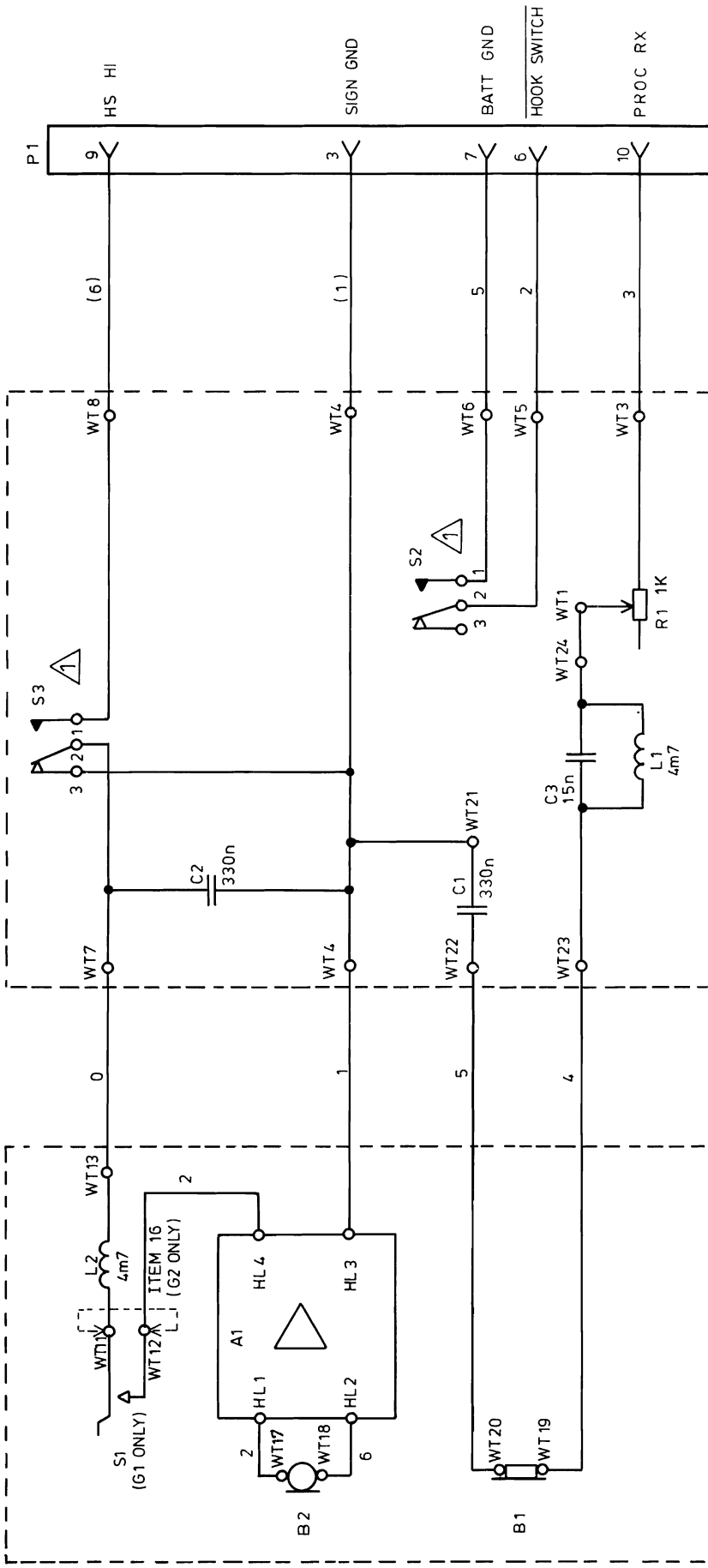

HANDSET

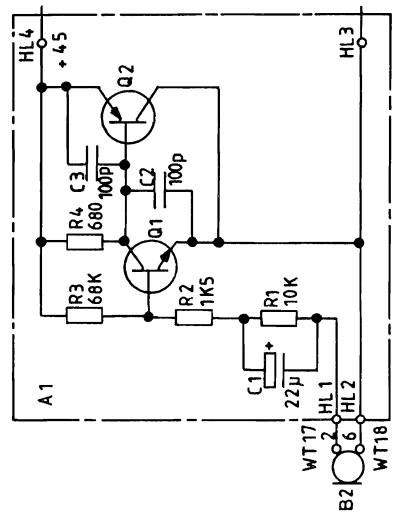

RETAINER

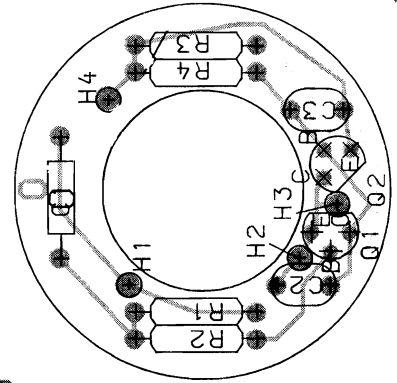

NOTE
 1 S2 AND S3 SHOWN WITH HANDSET IN RETAINER
 IEC 304 COLOR CODES ON WIRES

COLOR CODE	IEC 304
0	BLACK
1	BROWN
2	RED
3	ORANGE
4	YELLOW
5	GREEN
6	BLUE
7	VIOLET
8	GREY
9	WHITE

HANDSET MT6005/6
 AND RETAINER CONNECTIONS

D404.216

ITEM NUMBER DESCRIPTION
M906134G1/G2 MT 6005/MT6006
=====

P A R T S L I S T :

CIRCUIT POSITION	COMPONENT ITEM NUMBER	COMPONENT DESCRIPTION	QUANTITY	
A001	K805070G1	ASM BD PW C9MT01 / MT 600X	1	(SEE BELOW)
B001	J706194P1	MICROPHONE INS 400R	1	
B002	J706194P1	MICROPHONE INS 400R	1	
C001	A700004P5	CAP PYES 330N 10% 63V	1	
C002	A700004P5	CAP PYES 330N 10% 63V	1	
C003	A700005P8	CAP PYES 15N 10% 50V	1	
L001	J707174P1	COIL RF FIX 4700UH 10%	1	
L002	J707174P1	COIL RF FIX 4700UH 10%	1	
R001	J706008P1	RES VAR CERM 1K0 20% 1/2W	1	
W001	J706182P1	CABLE ASSY HANDSET 6COND	1	
W002	K805030G4	CABLE ASM MT6005/6006	1	SEE: PAGE 2
0002	J706073P1	NETTING	2	
0003	L855026P1	HOLDER	2	
0004	J706074P1	PLATE	1	
0005	J706195P1	HANDSET CASE BARE BLACK	1	
0006	A701268P6	WIRE BLUE	0.10 M	
0007	A701268P2	WIRE RED	0.10 M	
0008	J706195P2	STOWACE FOR 2 SWITCHES	1	
0009	J706202P7/P8	NAME PLATE MT 6005/6006	1	
0011	J707335P2	CLAMP LOOP 6 MM	1	
0012	A701268P2	WIRE RED	0.160 M	
0014	A701268P2	WIRE RED	0.20 M	
0015	J707206P1	COV. BLIND FOR MT6006	1	
0016	A701268P10	WIRE BLACK FOR MT6006	0.10 M	
0017	A701268P5	WIRE GREEN	0.180 M	
0019	J706075P1	GROMMET	1	
0020	K805023P1	GROMMET	1	
0021	J706313P1	RIVET TUBR D-6.0 L-9.0	2	
0022	J706433P1	TAPE ACET WDH 12.7 MM	0.10 M	
0023	A701268P4	WIRE YELLOW	0.050 M	
0024	A701268P1	WIRE BROWN	0.120 M	
0025	A701268P10	WIRE BLACK	0.140 M	
0026	A701268P6	WIRE BLUE	0.160 M	
0027	A701268P1	WIRE BROWN	0.060 M	
0028	A701507P108	SCREW PAN HD SZ4.8X12.7AB	4	
/-----/				
A001 :	K805070G1 :	ASM BD PW C9MT01 / MT 600X :		
C001	B800650P21	CAP TA SOL 2U2 20% 15V	1	

CIRCUIT POSITION	COMPONENT ITEM NUMBER	COMPONENT DESCRIPTION	QUANTITY
C002	A700233P1	CAP CER CL2 100P 20% 50V	1
C003	A700233P1	CAP CER CL2 100P 20% 50V	1
Q001	A700017P1	TSTR NPN SI BC 548A/B	1
Q002	A700020P1	TSTR PNP SI BC553A/B	1
R001	A700019P49	RES DEPC 10K 5% 1/4W	1
R003	A700019P57	RES DEPC 47K 5% 1/4W	1
R004	A700019P35	RES DEPC 680R 5% 1/4W	1
W001	A700184P1	RES WIRE JMPR	1
0002	L855097P1R0	BD PW., REVISION NO.: 0	1

W002 :	K805030G4 :	CABLE ASM MT 6005/6006:	

P001	J708069P210	CONNECTOR FEMALE	1
0002	J706152P5	STRAP RET., W. BDL D19 NYL.	1
0003	L706156P2	CABLE	2.50 M

Power Supply Unit PS702

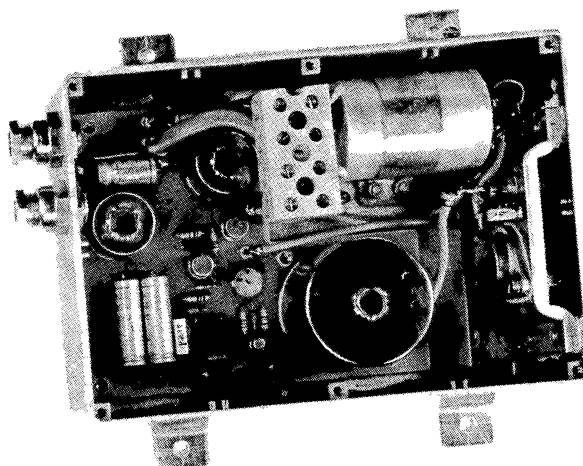

The PS702 power supply is a switching regulator for converting a 24 V input voltage to 12 V output to supply a CQM700 radiotelephone.

The conversion from a high to a lower voltage is accomplished by alternately applying the input voltage (V_{IN}) and 0 volts (ground potential) to an LC lowpass filter, as shown below.

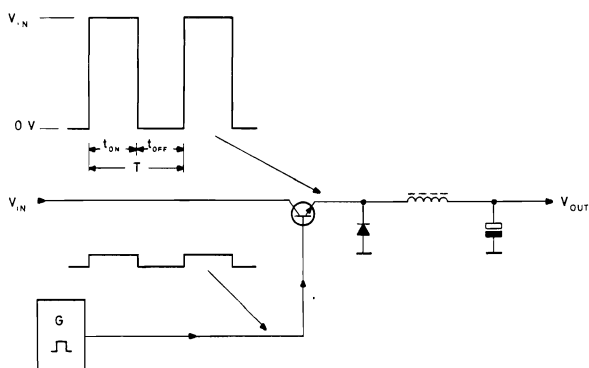

The output voltage will be the average value of the switched waveform. If the voltage drop across the transistor and diode is neglected, the output voltage will be:

$$V_{OUT} = V_{IN} \times \frac{t_{ON}}{T}$$

which, in the case of a symmetric square wave and a 24 V input will be:

$$24 \text{ V} \times 1/2 = 12 \text{ V}$$

In addition, there will be a small amount of ripple voltage whose fundamental frequency is the switching frequency.

Notice that the output voltage, according to the formula, is independent of the load current.

A regulating circuit monitors the output voltage and compares it to a reference voltage. The regulating circuit then accordingly regulates the ratio between ON and OFF time. Thus the output voltage is maintained at the proper level regardless of input voltage or load current.

A current regulating circuit protects the series switch transistors against being destroyed by overloads or short circuits at the power supply output.

LC filters in both the input and output circuits prevent excessive radiation of noise along the input and output leads.

Due to the switching principle the efficiency of this power supply is high, efficiency is on the order of 85%.

SWITCHING CIRCUIT

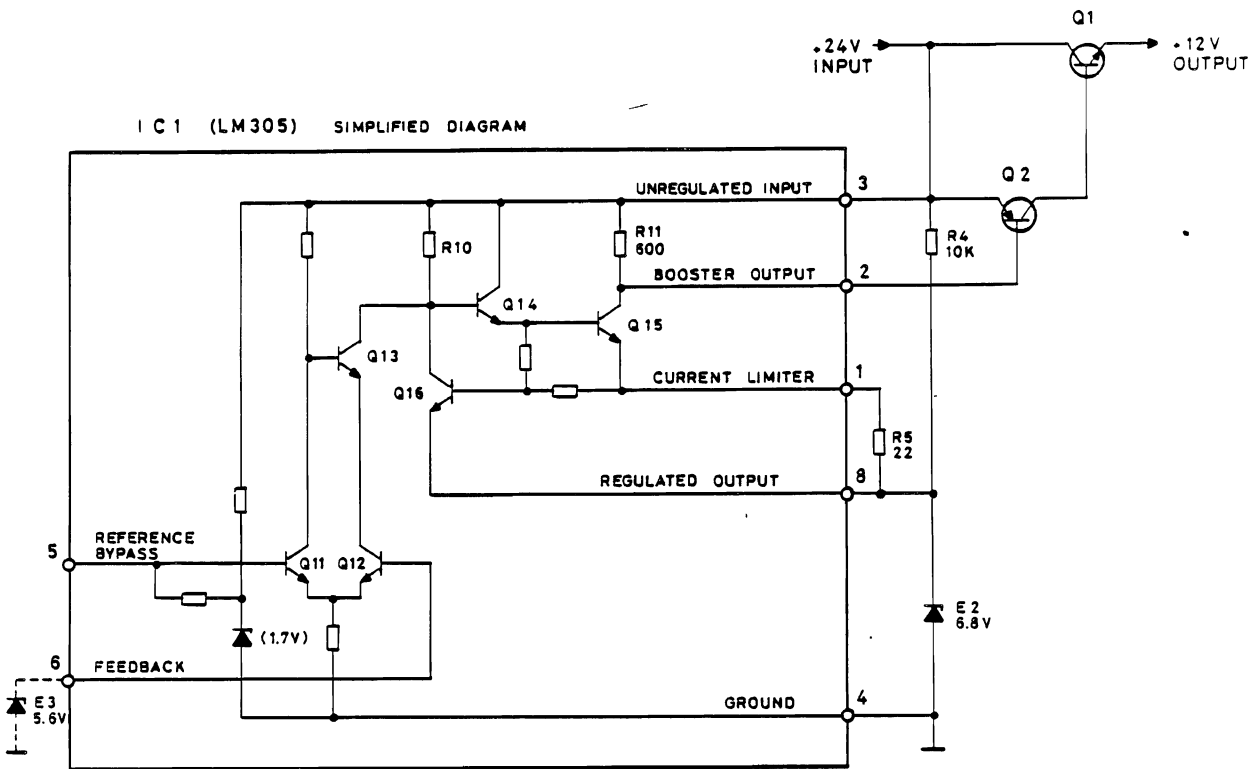

The LM305 integrated voltage regulator, IC1, drives the PNP switching transistor, Q2. An additional, NPN transistor, Q1, enables the circuit to handle the heavy currents required by the radiotelephone set (up to 8 amperes).

Q11 and Q12 make up a differential amplifier. The input from IC pin 6 is the inverting input, referred to as the feedback input. The non-inverting input, from IC pin 5, is called the reference bypass. This input is held at a potential of 1.7 V (typical value) by the internal IC circuitry. This potential is called the reference voltage.

If the voltage on input pin 6 is less positive than the reference voltage at the base of Q11, the differential amplifier turns Q13 OFF. This is how: Q11 conducts, pulling the base of Q13 LO while at the same time Q12 cuts off via emitter feedback, preventing any emitter current to flow through Q13. When Q13 goes OFF its collector is pulled up by R10, turning Q14

and Q15 ON. Notice that Q15's 600 ohm collector resistor, R11, is also the emitter-base biasing circuit for Q2, the switching transistor. Thus, when Q15 is driven ON, the collector current through R11 turns Q2 ON, as well. Q2 supplies drive to Q1, which also switches ON.

Now, if a voltage more positive than the internally generated reference voltage is applied to IC pin 6, Q12 will go ON, cutting Q11 OFF. The differential amplifier now forward biases Q13, which goes ON, turning Q14 and Q15 OFF. With no collector current through R11, Q2 loses its forward bias and switches OFF, also switching Q1 OFF.

In addition, there is a built-in current limiting feature in this circuit. Base current for Q2 flows via IC pin 2 (booster output), Q15, R5, and E2 to ground. The 22 ohm resistor R5 is called the current limiting resistor and is also the source of emitter-base bias for Q16. Whenever base current for Q2 tends to exceed the limit set by

the value of R5, Q16 will begin to draw current through R10. This reduces the bias to Q14 and Q15, creating a state of equilibrium where the amount of base drive to Q2 is determined by the value of R5.

With a value of 22 ohms chosen for R5, the current will be limited to about 15 mA for temperatures within the nominal operating range.

Zener diode E2 keeps the regulated output voltage at IC pin 8 at approximately 6.8 V. E3, a 5.6 V Zener diode, is wired to IC pin 6. This ensures that the voltage to the feedback terminal cannot rise higher than the voltage at IC pin 1. Otherwise the circuit can latch up and burn out.

OSCILLATOR CIRCUIT

The integrated voltage regulator, IC1, monitors the output voltage by measuring the portion of the DC voltage that is dropped across R10. It also measures the full amplitude of the output ripple via bypass capacitor C5. Thus the instantaneous ripple amplitude adds with the sampled DC voltage at input terminal 1, pin 6 of IC1.

When power is initially to the PS702 there is no voltage at the output. Therefore there can be no bias available at pin 6 of IC1, and the internally generated reference voltage present at the noninverting input, pin 5, will then be able to drive the IC ON, which in turn drives Q2, then Q1, into conduction as well.

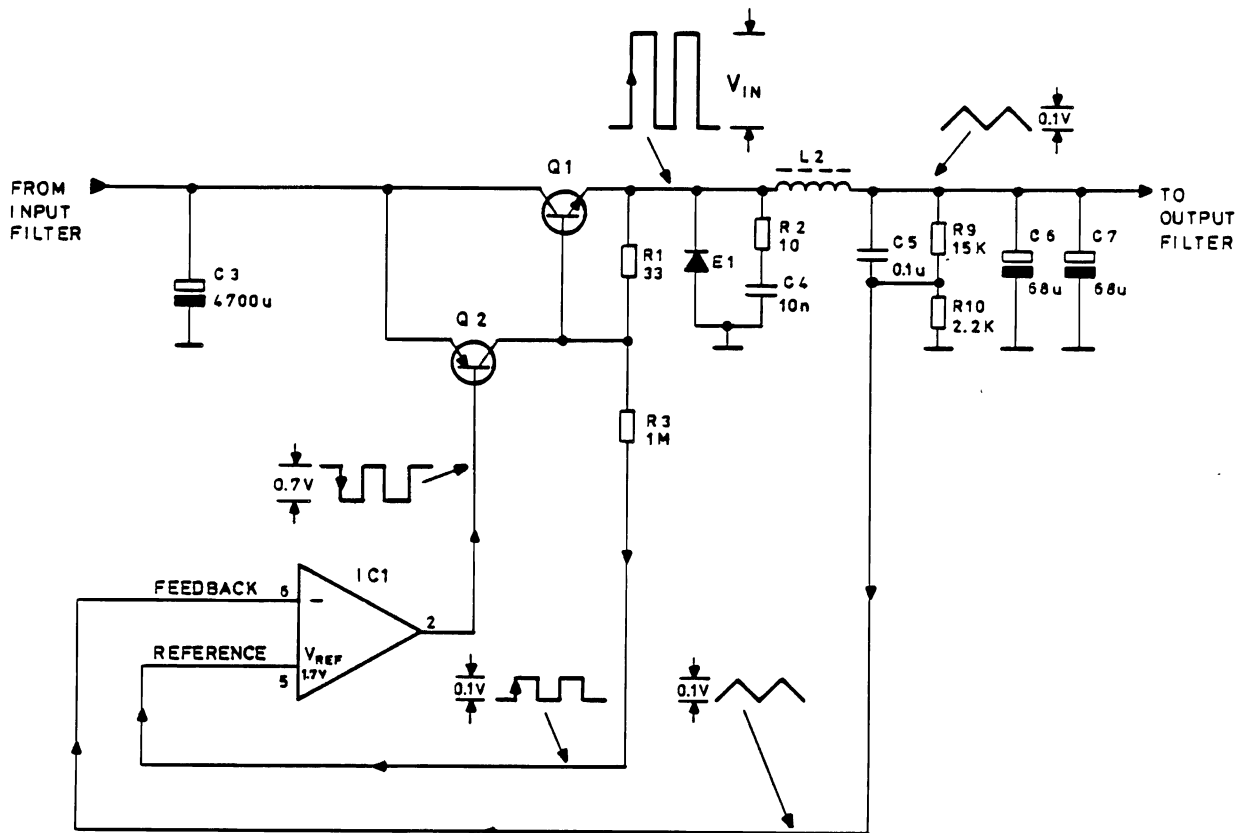

A positive voltage now begins building up on the collector of Q2 as well as on the emitter of Q1. A small portion of this rising voltage is fed back through resistor R3 to IC1 input terminal, pin 5. The amplitude of the feedback signal is determined by the ratio of R3 to the input impedance of the terminal. The polarity of the feedback signal is such that it causes the voltage at terminal 5 to become even more positive. This regenerative feedback therefore increases the gain of the amplifier, driving Q1 and Q2 even harder. (In fact, the amplitude of the feedback signal is sufficient to sustain oscillation in the circuit). Of course, this all happens very quickly, during the rise time of the square wave.

Meanwhile, filter capacitors C6 and C7 are charging up to the input voltage through L2 and Q1. The DC charge on these parallel capacitors is divided between R9 and R10. Remember, too, that C5 bypasses ripple voltages (including charging waveforms) around R9, directly to pin 6 of the regulator IC.

At some point the combined AC and DC voltages as seen at pin 6 of IC1 will become greater than the bias at pin 5, which bias is equal to the internal reference voltage plus the instantaneous value of the feedback signal. Now when the potential at terminal 6 has become more positive than that at terminal 5, the regulator switches state and cuts Q2 and Q1 OFF.

When this happens the magnetic field induced in coil L2 will attempt to maintain the current flow through the coil and in so doing biases catch diode E1 into forward conduction, in effect grounding the emitter of Q1. As seen at IC pin 5, the regenerative feedback via R3 is now a negative-going pulse. This, of course, is the correct polarity for driving the integrated amplifier and the switching transistors even further into cut-off.

The circuit remains cut off until C6 and C7 discharge enough so that the potential seen at pin 6 falls below that at pin 5 (the reference voltage minus the feedback signal). At this point the IC switches state again and the circuit continues in this way to oscillate at a frequency determined by the reactance of L2, the capacitances of C6 and C7, and the amplitude of the feedback signal. Feedback resistor R3 is what determines the amplitude of the feedback signal.

(It is worth mentioning here that the output voltage does not reach its full 12 V potential immediately, but in several increments governed by the oscillator excursions and the frequency of oscillation. However, once the output voltage reaches its full value, it remains constant with only a slight ripple voltage).

The amplitude of the feedback signal, typically 100 mV, determines how great a voltage excursion the oscillator circuit must self-compensate for, the ripple superimposed on the filter capacitors C6 and C7 will have essentially the same amplitude as the feedback signal voltage. With L2, C6, and C7 as circuit constants, the rate of charging the filter capacitors is also constant. Thus, if the capacitors have to charge (or discharge) to a relatively greater voltage before the oscillator switches state, it will take a longer time to do so. On the other hand, if the feedback and ripple amplitudes are relatively less, the capacitors can reach the threshold levels in less time. This is what determines the frequency of oscillation.

The oscillator frequency is approximately 25 kHz. This frequency was chosen as a compromise between efficiency, which improves with lowering frequency, and the necessity of ensuring against radiating undesired signals that would fall within the audible range.

An RC network consisting of R2 and C10, across catch diode E1, is a damping circuit used to attenuate switching transients that appear across E1. As explained earlier, E1 conducts heavily when Q1 is turned OFF. Right as Q1 goes ON again, E1 will still conduct because of its inherent reverse recovery time. The diode will thus act as a short circuit and a strong surge will pass from C3 through Q1 and E1. When all the charge stored in the catch diode is removed, the diode no longer conducts and pulse transients arise. At this point the damping circuit must handle the surge transients. This current surge, with its attendant transients, is the main cause of RF noise generated in the power supply.

OUTPUT CURRENT LIMITER CIRCUIT

Output current limiting is performed by comparator IC2. It compares the voltage drop across the 0.01 ohm resistor, R8, to the 82 ohm resistor, R7. Resistor R7 is in series with the constant current generator, Q3, and there will therefore be a uniform voltage drop across the resistor. On the other hand, resistor R8 is in series with the output load, so the voltage drop across R8 will depend upon the varying load conditions.

As long as the load current remains below a certain limit the voltage drop across R8 will be less than that across R7, and IC2 is held OFF.

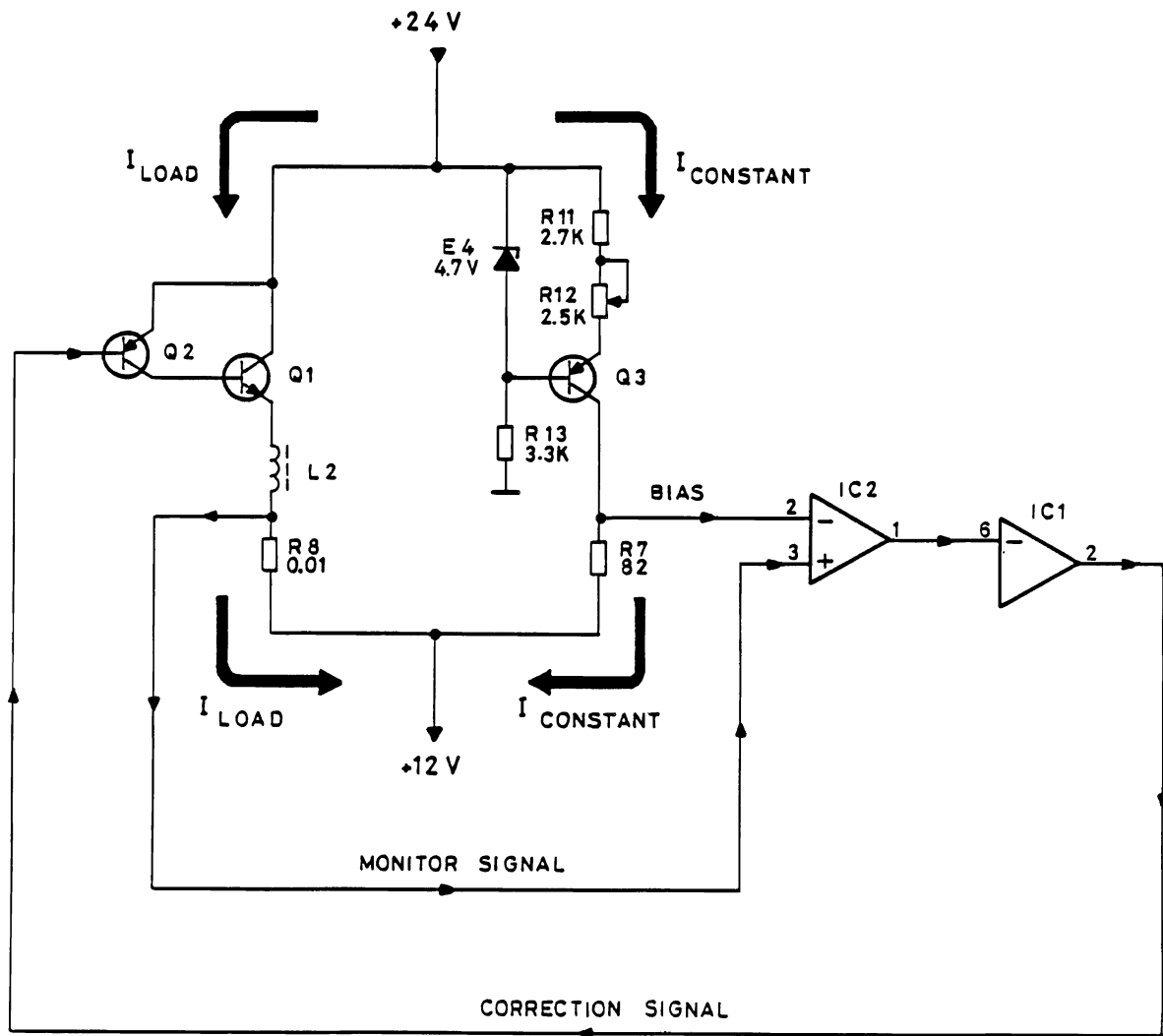

When the load current increases, so does the voltage drop across R8, and if the current surpasses the set limit the voltage across R8 becomes greater than the voltage across R7. Now just the opposite condition exists: IC2 goes ON, driving IC1 OFF, which in turn switches Q2 and Q1 OFF, as well.

The maximum allowable load current before limiting will take place is set by adjusting potentiometer R12. Since R12 is in the emitter circuit of the constant current generator, Q3, its setting determines the voltage drop across R7.

Battery Protection

A double fuse box with two 5A fuses must be inserted in the leads from the battery and the vehicle chassis, one fuse in the battery lead and one in the chassis lead. It is not necessary to fuse the connections between power supply and CQM700 equipment.

SERVICING

A good practice to observe when servicing the PS702 is to load the output with a 50 ohm, 15W resistor or a suitable rheostat. Otherwise, if allowed to operate unloaded, the oscillator runs irregularly. This is a normal phenomenon and has no bad effect on the power supply, but it could be misleading when checking the performance of a unit.

Technical Specifications

Supply Voltage

minimum:	21.0 V
nominal:	27.2 V
maximum:	32.0 V

Output Voltage

minimum:	10.5 V
maximum:	16.0 V

Output Load

for output voltage > 10.5 V: 8 A min.

Output Ripple Voltage

< 50 mV p.p.

Current Consumption

27.2 V supply, unloaded output:	10 mA
21.0 V supply, 8.0 A output load:	5.8 A
27.2 V supply, 8.0 A output load:	4.6 A

Efficiency

for $I_L > 0.5$ A: 87%

Ambient Temperature Range

(for continuous duty at 8 A)

operating range:	-25°C to +40°C
functioning range:	-25°C to +80°C

(for intermittent duty,

average load ≤ 4 A and duty period ≤ 20 min.)

operating range:	-25°C to +60°C
functioning range:	-25°C to +80°C

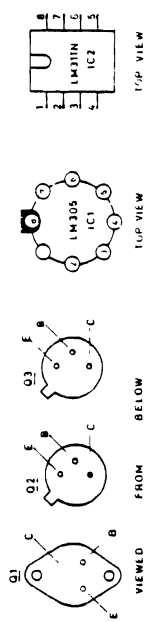
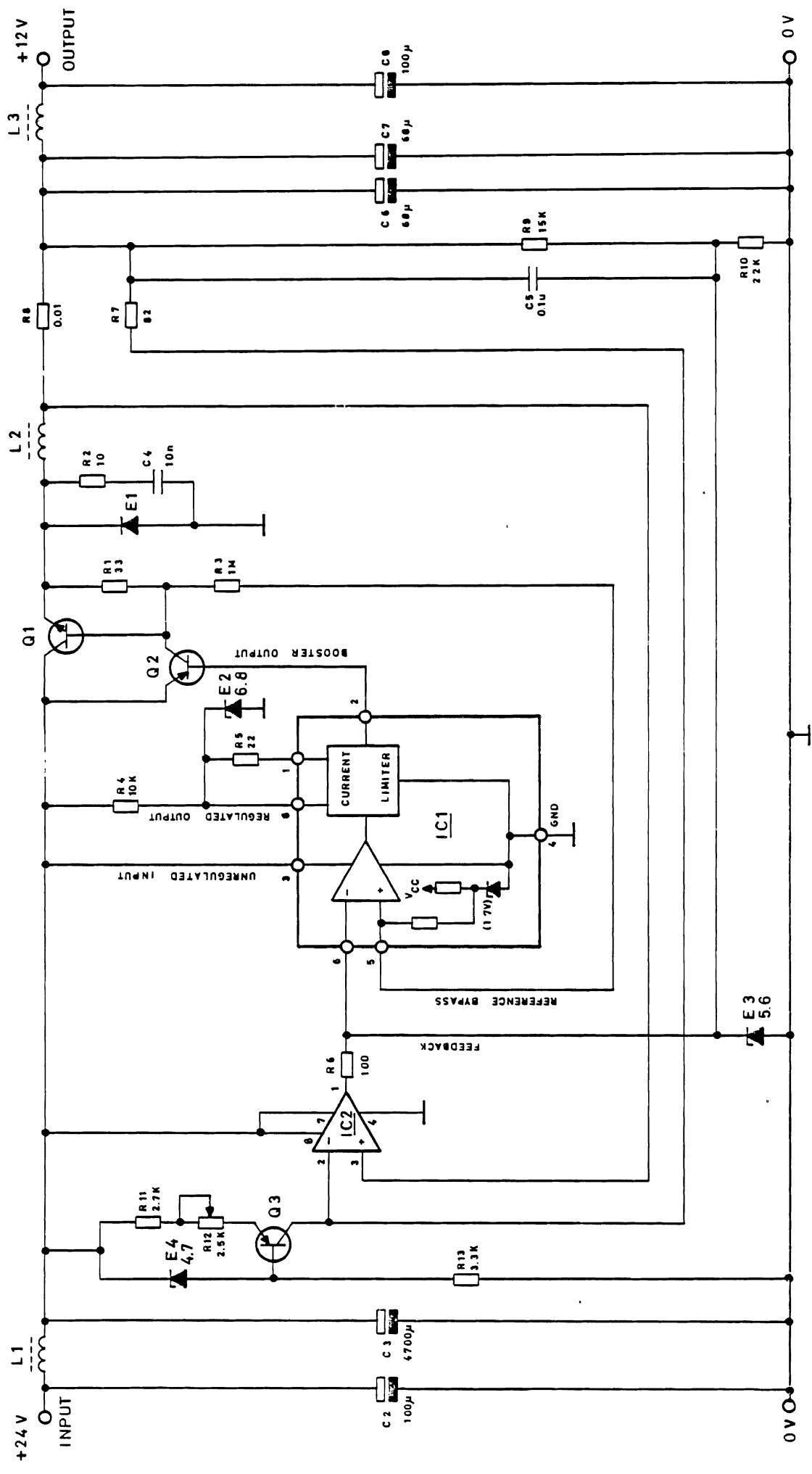

POWER SUPPLY PS702

D401.870/2

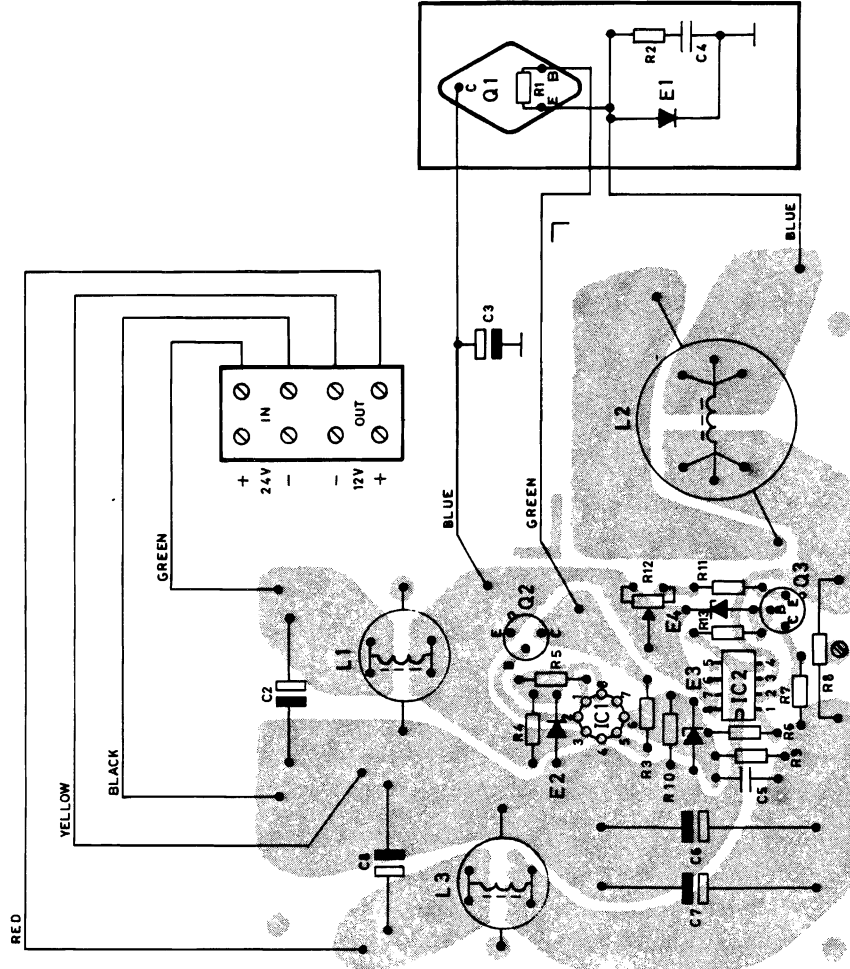

POWER SUPPLY PS702
STRØMFORSYNING

D402.096

ITEM NUMBER	DESCRIPTION
10.2918-00	PS 702
=====	
15.0186-00	SUBASSEMBLY (PS702)
15.0187-00	SUBASSEMBLY (PS702)
15.0188-00	SUB-SUBASSEMBLY (PS702)

P A R T S L I S T :

CIRCUIT POSITION	COMPONENT ITEM NUMBER	COMPONENT DESCRIPTION	QUANTITY	
A01	15.0186-00	SUBASSEMBLY (PS702)	1	(SEE BELOW)
A02	15.0187-00	SUBASSEMBLY (PS702)	1	SEE: PAGE 2
0	A700031P408	SCREW PAN HD M-3.0X8.0	8	
0	A700034P4	NUT HEX M-3.0X0.50	4	
0	J706076P5	WASHER SPG 3.0X6.4	8	
0	J708543P2	WASHER	4	
0	J708564P1	WASHER	4	
0	J708565P1	GASKET	2	
0	11.1012-00	CABINET, DRILLED-	1	
0	11.1013-00	PLATE, CONNECTION-	2	
A	17.0076-00	KIT, MOUNTING-	1	
0	20052-03008	SCREW 3X8 FLAT H-POZ	4	
0	38.5006-01	CABLE SEALING GLAND	1	
0	51.0796-00	LABEL, TYPE-	1	
0	51.0806-00	LABEL	1	
0	51.0992-00	LABEL	1	
/-----/				

A01 : 15.0186-00 : SUBASSEMBLY (PS702) :

C04	74.5109-00	CAP CER PL 10N 20% 63V	1
D01	99.5289-00	DIODE PWR SI BYX 50-200R	1
Q01	99.5261-00	TSTR NPN SI BDY 91 / 2N5039	1
R01	A700019P19	RES DEPC 33R 5% 1/4W	1
R02	A700019P13	RES DEPC 10R 5% 1/4W	1
W	18.0767-00	WIRING, FLEX.-	1
0	A700034P4	NUT HEX M-3.0X0.50	1

CIRCUIT POSITION	COMPONENT ITEM NUMBER	COMPONENT DESCRIPTION	QUANTITY
0	A700035P410	SCREW FLAT HD M-3.0X10.0	1
0	J706076P4	WASHER SPG 2.5X5.9	1
0	J706076P5	WASHER SPG 3.0X6.4	1
0	J706076P7	WASHER SPG 5.0X10.5	1
0	20022-04015	SCREW K-K 4X15 MM DIN 798	2
0	2401-090043	WASH. UDST 9X4,3X1,0 MM	2
0	34.5009-00	SOLDER LUG	1
0	34.5019-00	SOLDER LUG	1
0	34.5033-00	SOLDER LUG	1
0	43.5005-00	INSULATOR, STAND OFF-	1
0	59.0041-00	PLATE, HEAT SINK-	1
0	59.5007-00	BUSHING, INSUL.-	2
0	99.5018-00	WASHER, MICA-	1

/-----/

A02 : 15.0187-00 : SUBASSEMBLY (PS702) :

A03	15.0188-00	SUBASSEMBLY	1	(SEE BELOW)
C03	73.5155-00	CAP ELEC 4700U -10+50% 40V	1	
W	18.0768-00	WIRING, FLEX.-	1	
0	A700031P420	SCREW PAN HD M-3.0X20.0	2	
0	A700034P4	NUT HEX M-3.0X0.50	2	
0	A700035P406	SCREW FLAT HD M-3.0X6.0	9	
0	J706076P5	WASHER SPG 3.0X6.4	2	
0	11.1014-00	PLATE, MOUNT.-	1	
0	20052-03008	SCREW 3X8 FLAT H-POZ	4	
0	31.0002-04	SPACER, THREADED-	2	
0	32.0429-00	PLATE, INSUL.-	1	
0	38.5023-00	BRACKET	1	
0	42.5024-00	TERMINAL	1	

/-----/

A03 : 15.0188-00 : SUBASSEMBLY :

C02	73.5071-00	CAP ELEC 100U -10 + 50% 35V	1
C05	76.5091-00	CAP PYES FL 0U1 20% 100V	1
C06	73.5154-00	CAP ELEC ELKO 68U 20% 16V	1
C07	73.5154-00	CAP ELEC ELKO 68U 20% 16V	1
C08	73.5071-00	CAP ELEC 100U -10 + 50% 35V	1

CIRCUIT POSITION	COMPONENT ITEM NUMBER	COMPONENT DESCRIPTION	QUANTITY
D02	99.5146-00	DIODE, ZENER- 6V8 5% 1/4W	1
D03	99.5114-00	DIODE, ZENER- 5V6 5% 1/4W	1
D04	99.5224-00	DIODE, ZENER- 4V7 5% 1/4W	1
L01	61.1235-00	COIL, FILTER-	1
L02	61.1236-00	COIL, FILTER-	1
L03	61.1237-00	COIL, FILTER-	1
Q02	99.5215-00	TSTR PNP SI 2N2905A	1
Q03	99.5251-00	TSTR PNP SI BC307A/B, BC557	1
R03	80.5085-00	RES DEPC 1M OHM 5% 0,1W	1
R04	A700019P49	RES DEPC 10K 5% 1/4W	1
R05	A700019P17	RES DEPC 22R 5% 1/4W	1
R06	A700019P25	RES DEPC 100R 5% 1/4W	1
R07	A700019P24	RES DEPC 82R 5% 1/4W	1
R08	J706037P1	RES WIRE 0R01,/1.0 .64, 35MM	0,001 KG
R09	A700019P51	RES DEPC 15K 5% 1/4W	1
R10	A700019P41	RES DEPC 2K2 5% 1/4W	1
R11	A700019P42	RES DEPC 2K7 5% 1/4W	1
R12	86.5043-00	RES VAR LIN 2K5 20% 0,1W	1
R13	A700019P43	RES DEPC 3K3 5% 1/4W	1
R1?	A700019P73	RES DEPC 1M0 5% 1/4W	1
U01	14.5054-00	IC LIN VOLT. REG. SG 305	1
U02	14.5070-00	IC LIN VOLT. COMP. LM 311 N	1
0	54.0663-00	PW BOARD, RIVETED-	1

POWER SUPPLY UNIT

C9PS04



The C9PS04 is a mains operated power supply for the Stornophone 900 radiotelephone. The unit consists of a mains transformer, a rectifier,

a smoothing filter, a switching regulator, and an output filter. The unit will supply 13.6 V stabilized DC when connected to a 220 V/240 V AC outlet.

CIRCUIT DESCRIPTION

POWER TRANSFORMER

The power transformer is wound on a toroidal core and has three windings, a 220/240 V primary and two 24 V secondary.

The 2 secondary windings are connected in parallel to the rectifier (D5) which gives the DC to the switching circuit.

SWITCHING REGULATOR

The switching circuit is built as a normal switching mode regulator with constant switching frequency, approximately 32 kHz, and variable duty cycle. The actual switching function is performed by the transistor configuration Q2, Q3, Q4 and the fly-back diode D4, which clamps the input of L-C filter L2-C8 to ground potential in that portion of the cycle where the switching transistors are off and D4 is forced to

conduct by the energy from the collapsing field of L2.

The output voltage across C8 is sensed by IC1a and compared to the reference voltage across D2-D3. The resulting signal is amplified by IC1b which is driving Q2 and in turn Q3 and Q4.

Output current limiting is achieved by monitoring the voltage drop across R17 and feed this voltage to IC1d. The IC1d output is 'OR-ed' with the voltage control signal at the IC1a output and therefore overrides the control voltage when the output current goes excessively high.

The two filters, C2-L1-C3, and C8-L3-C9, are ripple-transient filters on the input and output and their function is to ensure that the inherent switching noise does not exceed acceptable limits on the input and output terminals, and the cables as well.

STRAPPING BOARD

The strapping board contains the output connector and is assembled to the cabinet and a printed board with soldered and riveted terminals:

- 3 terminals connecting the mains transformer primary windings and the mains connection.

- 1 terminal connecting the screen for the mains transformer.
- 1 terminal connecting the mains transformer screen to cabinet.
- 2 terminals connecting the output from the switching circuit to the output connector assembled to the cabinet.

TECHNICAL SPECIFICATIONSMains Voltage

220/240 V AC +12/-12%; 50-60 Hz

Power Consumption

Approx. 15 mA, 0 Amp load

Approx. 500 mA, 7 Amp load

Output Voltage

13,6 V DC $\pm 2,0$ V

Output Current

Maximum 7 A (short circuit protected)

Output Voltage Ripple

Less than 100 mV pp (peak to peak)

Switching Frequency

Approx. 32 kHz

Temperature Range

-25°C to +55°C

Dimensions

L = 240 mm, W = 185 mm, H = 85 mm

Weight

4,5 kg

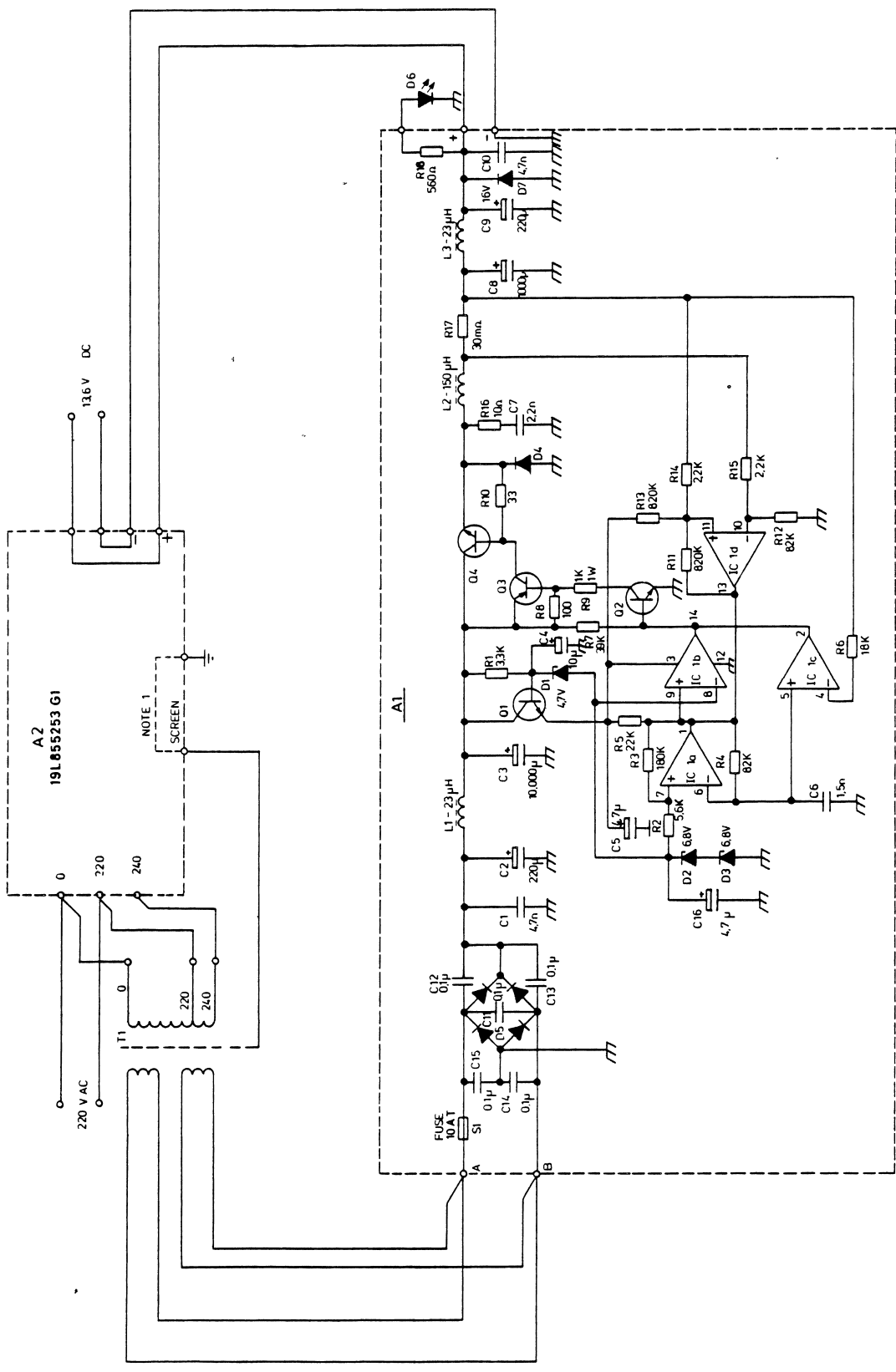

NOTE 1
CONNECTION IN G2 ONLY

MOUNTED BOARD
CODE NO
A1 19M905312 G1
A1 19M905312 G2

POWER SUPPLY C9PS04
D4.03.261

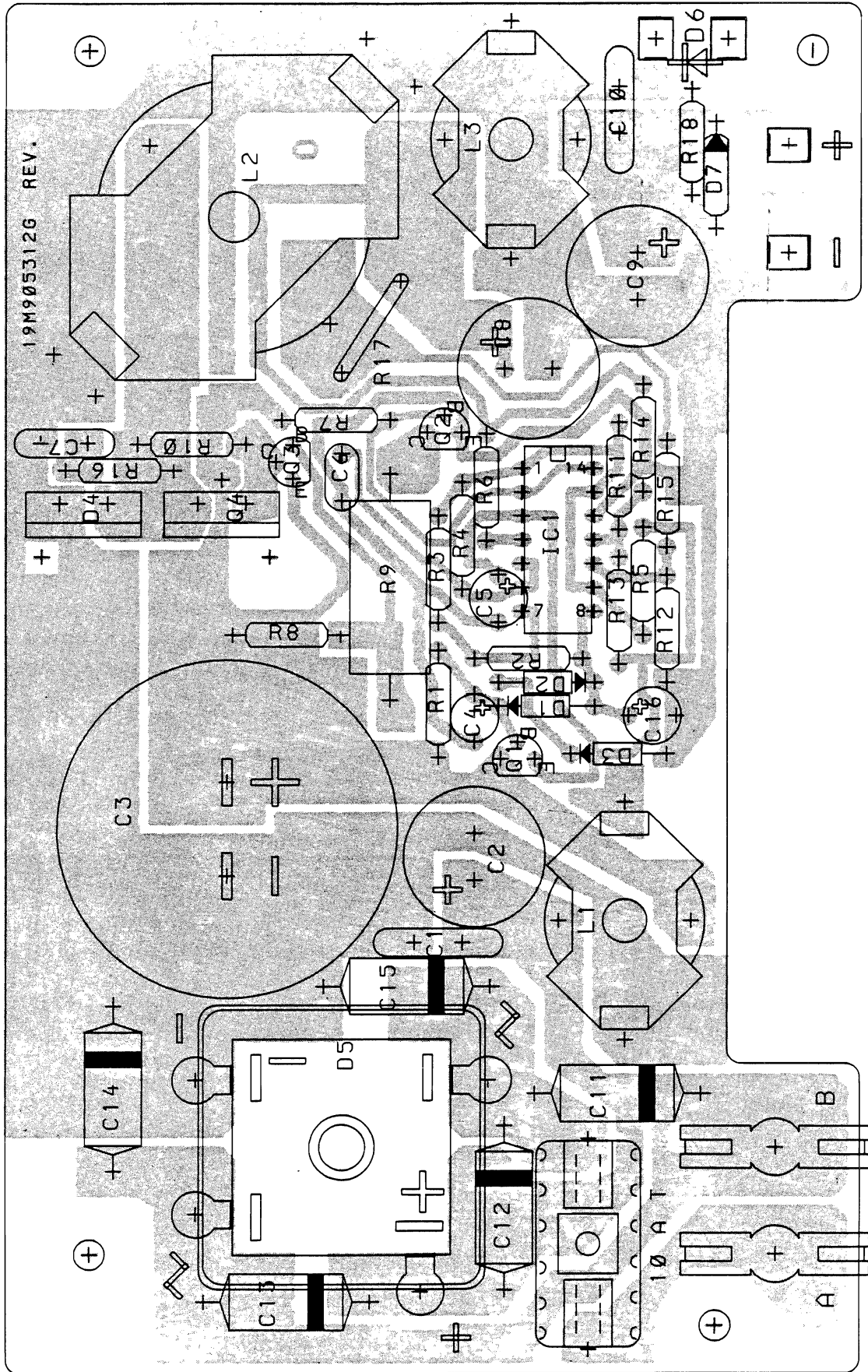

POWER SUPPLY C9PS04
COMPONENT LAYOUT

D403.262

ITEM NUMBER	DESCRIPTION
M905344G1	C9PS04
=====	
M905312G1	A1 : SUB ASM., CPNT BD PW PS 904
L855253G1	A2 : SUB ASM., CPNT BD PW

P A R T S L I S T :

CIRCUIT POSITION	COMPONENT ITEM NUMBER	COMPONENT DESCRIPTION	QUANTITY TOTAL
A1	M905312G1	ASM BD PW PS 904	1
* A2	L855253G1	ASM BD PW	1
D6	J706136P2	DIO OPTO	1
T1	J706961P1	TRANSFORMER MAINS 270VA	1
002	L855258G1	CHASSIS ASM	1
003	J707114G1	CA PWR	1
004	J707114G2	CA PWR	1
006	L855270P1	COVER	1
* 007	J707001G1	KIT	1
008	K805244G1	HT SK	1
009	J706982P1	WASHER	2
010	J706961P2	MTG DISC J706961P1	1
011	J706992P1	SPACER	4
013	J706999P1	INS PLT	1
015	J706921P1	RETAINER	1
016	J707000P1	NP	1
017	J706961P3	MTG WASHER, RUBB.	2
018	K805023P1	GROMMET	1
019	J706968P1	CABLE ASSY POWER 2-COND	1
021	J706902P1	CLAMP, CA	1
022	J706902P2	CLAMP, CA	1

A01 : ITEM NUMBER M905312G1 : DESCRIPTION ASM BD PW., PS 904 :

C01	A700001P11	CAP CER 4,7NF 50V	1
C02	J706005P14	CAP ELEC 220U 40V	1
C03	J706957P2	CAP ELECT 10.000MF 40V	1
C04	A701534P4	CAP TA SOL 1U 20% 35V	1
C05	A701534P6	CAP TA SOL 4U7 20% 35V	1
C06	A700234P2	CAP PYES 1N5 10% 50V	1
C07	A700233P9	CAP CER 2N2 10% 50V	1
C08	J706005P7	CAP ELEC 1000U 16V	1
C09	J706005P10	CAP ELEC 220U 25V	1
C10	A700001P11	CAP CER 4,7NF 50V	1

CIRCUIT POSITION	COMPONENT ITEM NUMBER	COMPONENT DESCRIPTION	QUANTITY TOTAL
C11	J706959P1	CAP PYES 0.1UF 100V	1
C12	J706959P1	CAP PYES 0.1UF 100V	1
C13	J706959P1	CAP PYES 0.1UF 100V	1
C14	J706959P1	CAP PYES 0.1UF 100V	1
C15	J706959P1	CAP PYES 0.1UF 100V	1
C16	A701534P6	CAP TA SOL 4U7 20% 35V	1
D1	A700025P5	DIO SI ZENR 4V7 5% 0,4W	1
D2	A700025P8	DIO SI ZENR 6V8 5% 0,4W	1
D3	A700025P8	DIO SI ZENR 6V8 5% 0,4W	1
D4	J706023P1	DIO SI PWR BYW 29-50	1
D5	J707044P1	DIO	1
D7	J706030P4	DIO SI ZENR 16V 5% 1W	1
L1	K805252G1	ASM COIL, 23 UH	1
L2	K805253G1	ASM COIL, 150 UH	1
L3	K805252G1	ASM COIL, 23 UH	1
Q1	A700017P1	TSTR NPN SI BC 548A/B	1
Q2	A700017P1	TSTR NPN SI BC 548A/B	1
Q3	A700026P1	TSTR PNP SI BC 369	1
Q4	J706015P1	TSTR NPN SI D44H8	1
R01	A700019P43	RES DEPC 3K3 5% 1/4W	1
R02	A700019P46	RES DEPC 5K6 5% 1/4W	1
R03	A700019P64	RES DEPC 180K 5% 1/4W	1
R04	A700019P60	RES DEPC 82K 5% 1/4W	1
R05	A700019P53	RES DEPC 22K 5% 1/4W	1
R06	A700019P52	RES DEPC 18K 5% 1/4W	1
R07	A700019P56	RES DEPC 39K 5% 1/4W	1
R08	A700019P25	RES DEPC 100R 5% 1/4W	1
R09	J706251P37	RES DEPC 1K0 5% 1/1W	1
R10	A700019P19	RES DEPC 33R 5% 1/4W	1
R11	A700019P72	RES DEPC 820K 5% 1/4W	1
R12	A700019P60	RES DEPC 82K 5% 1/4W	1
R13	A700019P72	RES DEPC 820K 5% 1/4W	1
R14	A700019P41	RES DEPC 2K2 5% 1/4W	1
R15	A700019P41	RES DEPC 2K2 5% 1/4W	1
R16	A700019P13	RES DEPC 10R 5% 1/4W	1
R17	J706891P1	RES CONST 0.030 OHM	1
R18	A700019P34	RES DEPC 560R 5% 1/4W	1
S1	J706998P13	FUSE CTG 10.0A	1
U1	J706018P1	IC LIN CMPAR 3302	1
008	J706903P1	FZ HLR	1
009	J706904P1	TERM SLD RLN 2689002	2
010	J706973P1	TERM,SLD 2.3 SQ HOLE	4
011	J706977P1	TERM SLD D 5 BEND	4
012	A700068P1	INS BUSH	2
013	A700115P3	INSULATOR PLATE	2
014	K805245P1	HOLDER	1

CIRCUIT POSITION	COMPONENT ITEM NUMBER	COMPONENT DESCRIPTION	QUANTITY TOTAL
---------------------	--------------------------	--------------------------	-------------------

MECHANICAL PARTS:

	A700031P305	SCREW PAN HD M 2.5X5.0	2
	A700031P310	SCREW PAN HD M 2.5X10.0	2
	A700031P406	SCREW PAN HD M 3.0X6.0	0
	A700031P413	SCREW PAN HD M 3.0X13.0	2
	A700032P5	WASHER LOK TOH D 3.0	3
	A700033P7	WASHER LOK TOH D 4.0	1
	A700034P6	NUT	1
	A700034P7	NUT	1
	A700036P406	SCREW PAN HD M 3.0X6.0	0
	A701502P1	BMPR	4
	A701847P205	SCREW THR FORM	2
	J706076P5	WASHER SPG 3.0X6.4	4

14/09/'84

STORNO - DEPT. OF SERVICE CO-ORDINATION

X403.762/2
